



Sirman Spa
 Viale dell'Industria 9/11
 35010 PIEVE DI CURTAROLO (PD), Italy
 Tel./Fax. +39 049 9698666 / +39 049 9698688
 email: info@sirman.com



Sirman Slicers , model Palladio 350 Automec :

- The Palladio Automec series offers the same outstanding features of the Palladio series adding:
 - Stainless steel base
 - Piston/rod system carriage motion
 - Fan-cooled carriage motion motor with commercial-grade oil bath reduction
 - Blade and carriage motion powered by separate controls
 - An easily accessible switch arm can convert the unit from automatic to manual operation
 - The exclusive designed carriage "Nettuno" is available with a special end weight and an adjustable vertical product fence to provide stability and advance products evenly.
- Two control systems:
- . Standard on/off
 - . Variable speed available (VV versions).



Controls



Large hopper



More space between blade and body machine

Data sheet

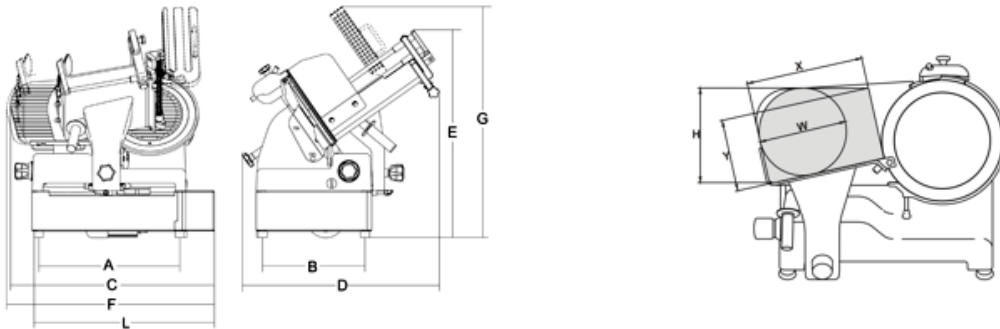

Technical data

Model	PALLADIO 350 AUTOMEC
ø blade	mm 350 - inch. 14
Motor	watt 370+180 - Hp 0,50+0,24
Cut thickness	mm 23
Run of carriage	mm 310
Hopper	mm 365x270
A	mm 465
B	mm 340
C	mm 685
D	mm 660
E	mm 670
F	mm 700
G	mm 750
L	-
X	mm 240/270
Y	mm 225
H	mm 275
W	mm 250
Net weight	kg 57
Shipping	mm 870x840x750

Gross weight	kg 72
HS-CODE	84385000