

# Specification

## CombiMaster® Plus 61 E (6 x 1/1 GN)

reference number:



Climate management - humidity measurement, 5-stage setting and regulation

### Combi-Steamer mode



Steam between 30 °C and 130 °C



Hot air from 30 °C-300 °C



Combination of steam and hot air 30 °C-300 °C

### Description

- Hot-air steamer (combi-steamer mode) conforming to DIN 18866 for most of the cooking methods used in commercial kitchens for the optional use of steam and hot air, individually, in succession or in combination.

### Working safety

- HACCP data output and software update via integral USB port
- Safety temperature limiter for steam generator and hot air heating.
- VDE approved for unsupervised operation
- Maximum rack height 5 ¼ ft. (1.60 m) when original stand used
- Integral fan impeller brake
- Door handle with right/left and slam function

### Operation

- Control lever for cooking modes, temperature, core temperature and time setting
- Self-lighting display, visible from a distance
- Clear control panel with pictograms

### Cleaning, care and operational safety

- Manual cleaning program
- Diagnostic system with automatic service notices display
- Menu-guided descaling program

### Features

- Interface USB
- Probe for core temperature measurement
- Individual programming of 50 cooking programs each with up to 6 steps
- 5 air speeds, programmable
- Integral, maintenance-free grease extraction system with no additional grease filter
- Cool down function for fast cabinet fan cooling
- High-performance fresh steam generator
- Automatic adaptation to the installation location (height, climate, etc.)
- Unit door with rear-ventilated double glass panel and hinged inner pane
- Seamless hygienic cooking cabinet with rounded corners, cabinet with splash guard - stops water spilling out
- Removable, swivelling grid shelves (distance between rails 68 mm)
- Material inside and out DIN 1.4301 stainless steel
- Separate solenoid valves for normal and softened water
- Fixed waste water connection conforming to SVGW requirements is permitted
- Splash- and hose-proof to IPX 5
- Demand-related energy supply
- Automatic, active rinsing and drainage of steam generator by pump
- Lengthwise loading for accessories
- Temperature unit adjustable in °C or °F
- Height-adjustable feet
- Airflow optimised cooking cabinet

### Approvals



Planner:

# Specification/Data sheet

## CombiMaster® Plus 61 E (6 x 1/1 GN)

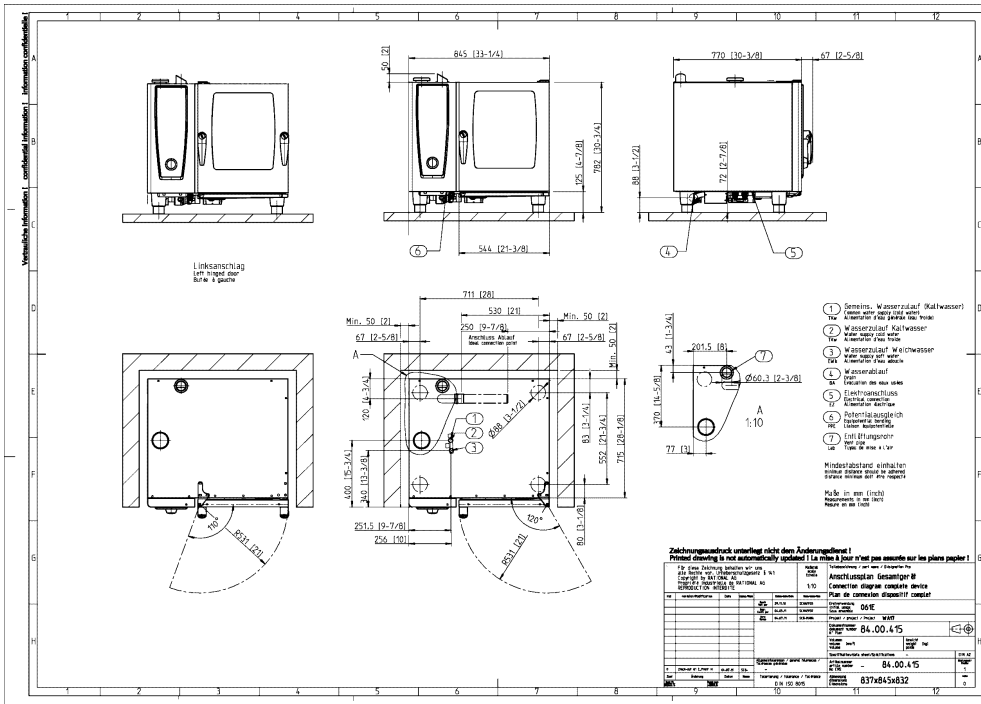

1. Common water supply (cold water)
2. Water supply cold water
3. Water supply soft or hot water
4. Water drain
5. Electrical connection
6. Equipotential bonding
7. Vent pipe DN 60
11. minimum distance 50 mm
13. Measurements in mm (inch)

### Technical Info

<b>Capacity (GN-container/grids):</b>	6 x 1/1 GN	<b>Water drain:</b>	DN 50 mm	<b>Mains connection</b>	<b>Fuse protection</b>	<b>Cable cross-section</b>
<b>Lengthwise loading for:</b>	1/1, 1/2, 2/3, 1/3, 2/8 GN	<b>Connected load:</b>	11 kW	3NAC400	3 x 16 A	5 x 2,5 mm <sup>2</sup>
<b>Number of meals per day:</b>	30-80	<b>"Steam" connection:</b>	9 kW	V 50/60Hz		
<b>Width:</b>	845 mm	<b>"Hot air" connection:</b>	10,3 kW	Other voltages on request		
<b>Depth:</b>	770 mm	<b>Weight (Net):</b>	99 kg			
<b>height:</b>	782 mm	<b>Weight (Gross):</b>	106 kg			
<b>Water connection (pressure hose):</b>	3/4" / d 1/2"					
<b>Water pressure (Flow pressure):</b>	150-600 kPa / 0,15-0,6 Mpa / 1,5 - 6 bar					

### Installation

- The left-hand gap must be a minimum of 350 mm if heat sources are acting on the left side of the unit.
- Installations must comply with all local electrical, plumbing and ventilation codes

### Options

- Marine version
- Security version/prison version
- left hinged
- Sous-Vide core temperature probe
- Interface Ethernet
- Potential free contact for operation indication included
- Safety door lock
- Externally attached core temperature probe
- Mobile oven rack
- Hand shower with automatic retracting system
- Lockable control panel
- Connection to energy optimising systems "Sicotronic" + Potential free contact for operation indication included
- Special voltages
- Unit with special hinging rack for bakers or butchers

### Accessories

- Gastronorm, Containers, Trays, Grids
- Stands/Cabinets
- Thermocover
- Transport trolley
- Exhaust hood
- UltraVent® Plus condensation hood with special filter technology.
- UltraVent® condensation hood
- Combi-Duo kits for 2 units one on top of the other
- KitchenManagement System
- Heat shield for left hand side panel
- Superspike (poultry grids), CombiGrill®
- Mobile oven rack and hinging rack for bakers
- Hinging rack for bakers or butchers
- Special Cleaner and Grill Cleaner
- Grease drip container
- Mobile plate rack

### RATIONAL-UK

Unit 4, Titan Court, Portenwey Business Park, Luton GB-Bedfordshire LU4 8EF; Phone +44-15 82-48 03 88; Fax +44-15 82-48 50 01

Visit us on the internet: [www.rational-online.com](http://www.rational-online.com)

We reserve the right to make technical improvements