

No.	F049-3353
ISSUED:	Jul. 1, 2010
REVISED:	Nov. 26, 2013



**HOSHIZAKI**  
**MODULAR CRESCENT CUBER**  
**MODEL KMD-270AA**

**PARTS LIST**  
(GENERAL)

V-1 JUL. 2010  
A-2 APR. 2011

## AUXILIARY CODE

U - 1

The auxiliary code is the first two characters in the serial number. The first character indicates the production year. Years progress or regress in alphabetical order. The series of letters and skipped letters depend on UL listing, production, and model. See the auxiliary code(s) and corresponding year(s) on the front cover.

The second character indicates significant part changes within the same year. Base is "1" and this number advances for each change. If there is no significant part change at the turn of the year, this number starts from "0."

## MARKS LOCATED UNDER THE AUXILIARY CODE

- = Part deleted.
- x = Part deleted and replaced by "o" part.
- o = New part in place of "x" part.

## FASTENER PART NUMBER

### SCREWS

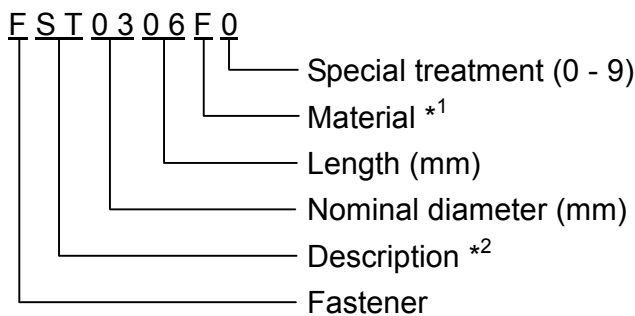

\*<sup>1</sup> Material

- F: Steel
- S: Austenitic stainless steel
- M: Martensitic stainless steel
- B: Copper alloy
- P: Polycarbonate
- N: Polyamide
- V: PVC
- A: ABS
- X: Polyacetal
- L: Aluminum

### NUTS & WASHERS

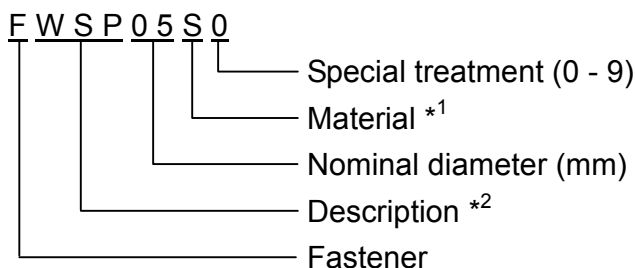

\*<sup>2</sup> Description

- First letter
- S: Machine screw
- T: Tapping screw
- M: Wood screw
- B: Bolt
- W: Washer
- N: Nut

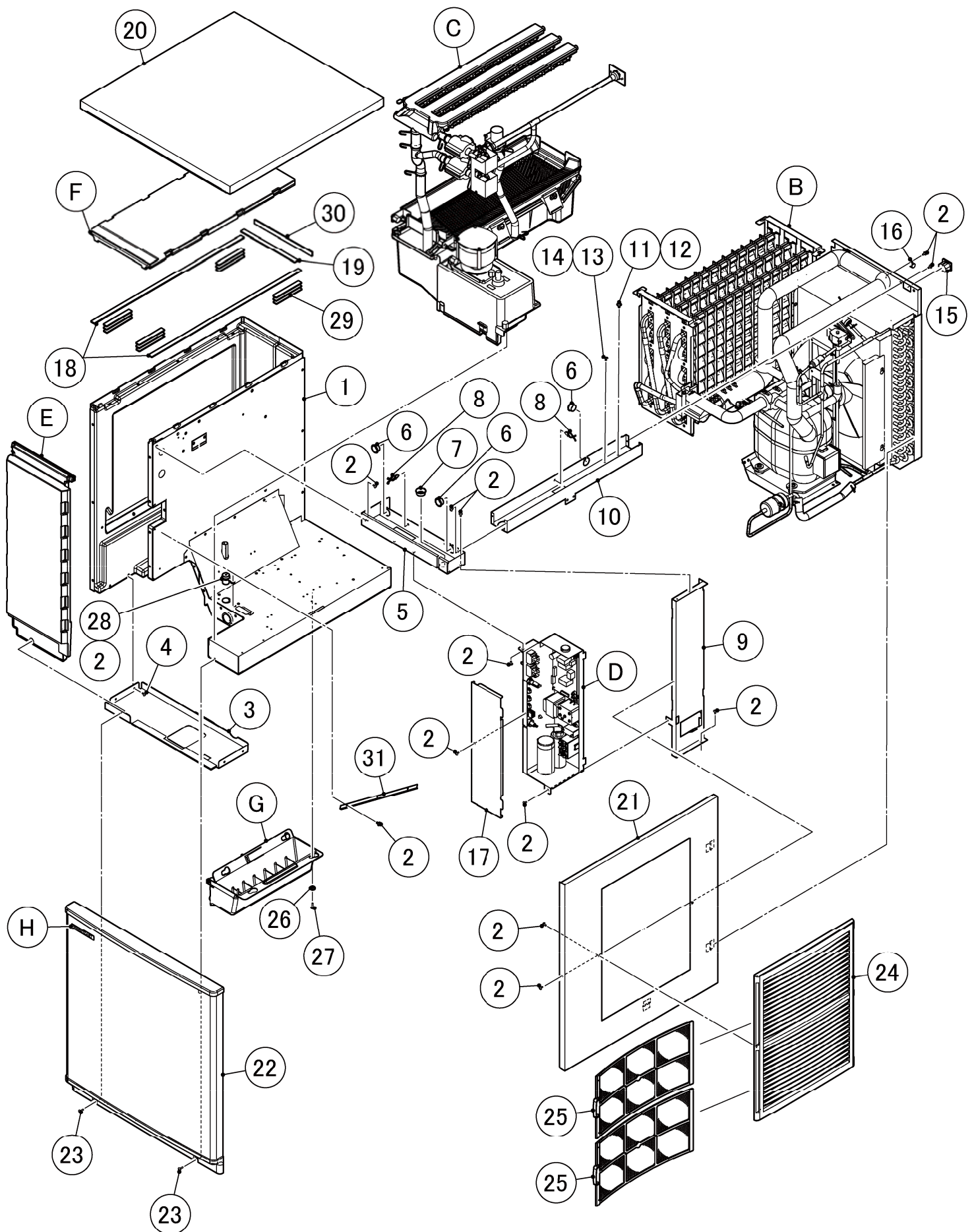

GENERAL

MODEL: <b>KMD-270AA</b> TITLE: <b>A. ICE CUBER ASSY</b>							
INDEX NO.	DESCRIPTION	MATERIAL OR MODEL NUMBER	PART NUMBER	REQ'D NUMBER			
				V-1,A-1	A-2		
B	REFRIGERATION CIRCUIT		120766A01	1	1		
C	WATER CIRCUIT		120458A01	1	1		
D	CONTROL BOX ASSY		258743A01	1	1		
E	FRONT INSULATION ASSY		371887A02	1	1		
F	TOP INSULATION ASSY		374537A01	1	1		
G	BIN SWITCH		371886A01	1	1		
H	LABEL LOCATION		120459A01	1	1		
L	ACCESSORIES		A02171-01	1	1		
1	EVAP. CASE		120764G01	1	1		
2	T2 SCREW	4X8	FT20408F0	18	21		
3	BOTTOM FRAME		371876M01	1	1		
4	T2 SCREW	4X8 SUS	FT20408M0	4	4		
5	TOP FRAME		371867M01	1	1		
6	BUSHING	OCB-875	428394-04	3	3		
7	BUSHING	OCB-750	428394-01	1	1		
8	CLAMP	No.249	427902-03	3	3		
9	SIDE FRAME (A)		371873M01	1	1		
10	SIDE FRAME (B)		371866M01	1	1		
11	SPRING WASHER	SUS 5	FWSP05S0	1	1		
12	TRUSS HEAD SCREW	SUS 5X8	FST0508S0	1	1		
13	SPRING WASHER	SUS 4	FWSP04S0	1	1		
14	TRUSS HEAD SCREW	SUS 4X8	FST0408S0	1	1		
15	CONNECTOR		P02656-01	1	1		
16	CLAMP	NK-6N	418814-06	1	1		
17	CONT. BOX COVER		371874M01	1	1		
18	GASKET	L=563	120455Z01	2	2		
19	GASKET	L=203	120455Z02	1	1		

GENERAL

MODEL: <b>KMD-270AA</b>		TITLE: <b>A. ICE CUBER ASSY</b>					
INDEX NO.	DESCRIPTION	MATERIAL OR MODEL NUMBER	PART NUMBER	REQ'D NUMBER			
				V-1,A-1	A-2		
20	TOP PANEL		255967M01	1	1		
21	SIDE PANEL (R)		255966G01	1	1		
22	FRONT PANEL		255965G01	1	1		
23	TRUSS HEAD SCREW	4X12 SUS	FST0412S0	2	2		
24	LOUVER		120457P01	1	1		
25	AIR FILTER		258589G01	2	2		
26	COLLAR		435269-01	4	4		
27	T2 SCREW	4X16 SUS	FT20416M0	4	4		
28	HOLE PLUG		373078R01	1	1		
29	GASKET	L=50	120455Z03	12	12		
30	GASKET	L=215	120455Z04	1	1		
31	PLATE - SIDE PANEL		379577M01		1		

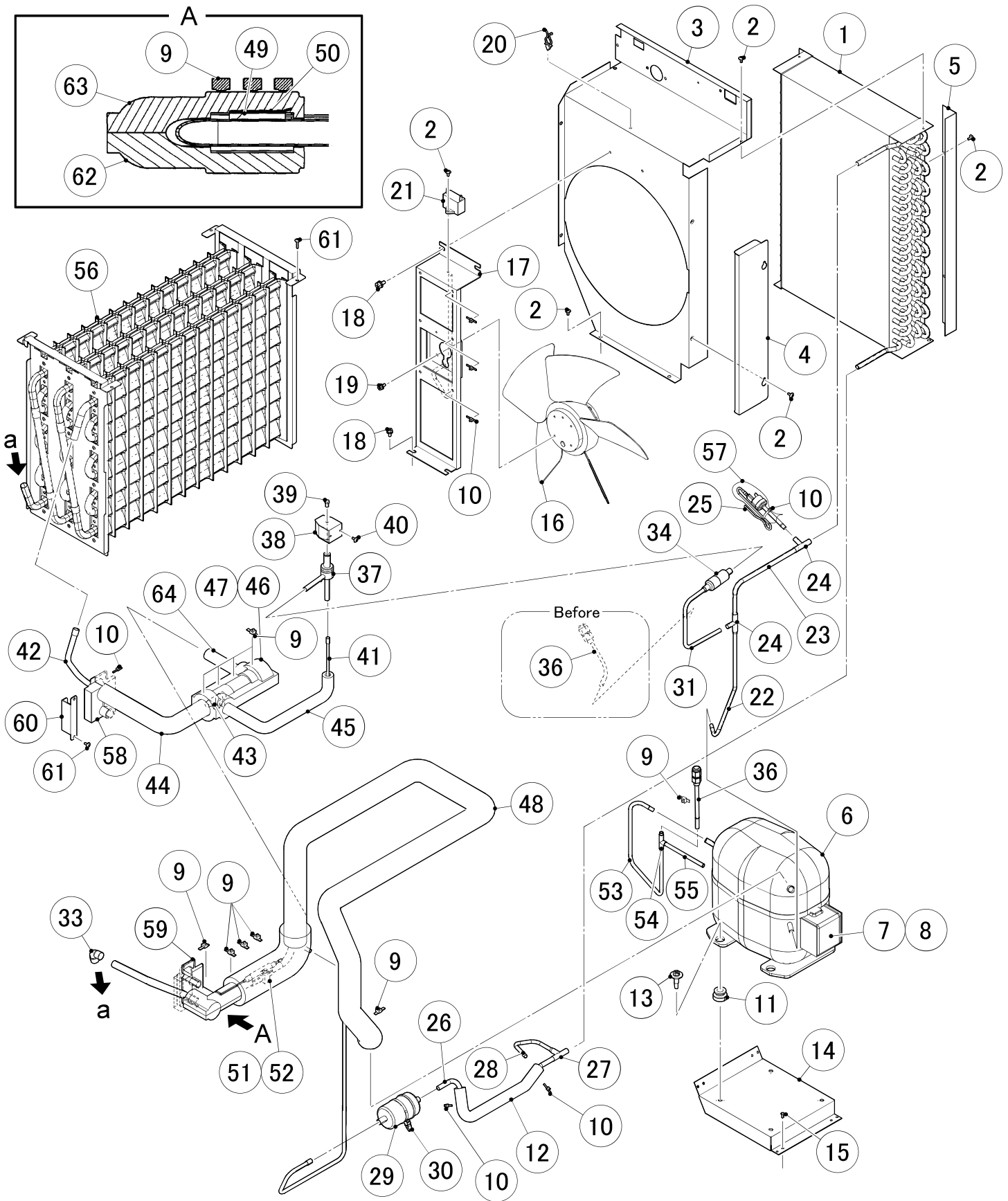

GENERAL

MODEL: <b>KMD-270AA</b>		TITLE: <b>B. REFRIGERATION CIRCUIT</b>					
INDEX NO.	DESCRIPTION	MATERIAL OR MODEL NUMBER	PART NUMBER	REQ'D NUMBER			
				V-1,A-1	A-2		
1	CONDENSER		P00814-01	1	1		
2	T2 SCREW	4X8	FT20408F0	16	16		
3	SHROUD		255968M01	1	1		
4	FAN BLADE COVER		371865M01	1	1		
5	BARRIER		371872M01	1	1		
6	COMPRESSOR		P01825-01	1	1		
7	COVER		459924-01	1	1		
8	CORD RELIEF		452239-01	1	1		
9	TIE	CV-200	7920-0010	14	13		
10	TIE	CV-100	7920-0002	7	7		
11	RUBBER GROMMET		450897-01	4	4		
12	INSULATION TUBE	7762-1020 L=245	H71020245	1	-		
		7762-1020 L=230	H71020230		1		
13	BOLT		468180-01	4	4		
14	COMP. MOUNT		374036G01	1	1		
15	RIVET	SSD43SSBS(t3.2~4.8)	7170-0005	8	8		
16	FAN MOTOR	A4E300-AE20-06	P00848-01	1	1		
17	FAN MOTOR BRACKET		371870G01	1	1		
18	HEX HEAD BOLT W/WASHER [SW]		FBK0510S0	4	4		
19	HEX HEAD BOLT W/WASHER [SW]		FBK0408S0	3	3		
20	CLAMP	No.249	427902-03	1	1		
21	CAPACITOR		P00849-01	1	1		
22	COPPER TUBE (A1) - HIGH SIDE	COPPER TUBE (A) - HIGH SIDE 374037G01	374140M01	1	1		
23	COPPER TUBE (A2) - HIGH SIDE	COPPER TUBE (A) - HIGH SIDE 374037G01	374037M01	1	1		
24	TEE	COPPER TUBE (A) - HIGH SIDE 374037G01	420041-02	2	2		

GENERAL

MODEL: <b>KMD-270AA</b>		TITLE: <b>B. REFRIGERATION CIRCUIT</b>					
INDEX NO.	DESCRIPTION	MATERIAL OR MODEL NUMBER	PART NUMBER	REQ'D NUMBER			
				V-1,A-1	A-2		
25	PRESSURE SWITCH		463180-04	1	1		
26	COPPER TUBE (B1) - HIGH SIDE	COPPER TUBE (B) - HIGH SIDE 258739G01	258739M01	1	-		
		260206G01	260206M01		1		
27	TEE	COPPER TUBE (B) - HIGH SIDE 258739G01,260206G01	420041-11	1	1		
28	COPPER TUBE (B2) - HIGH SIDE	COPPER TUBE (B) - HIGH SIDE 258739G01	258739M02	1	-		
		260206G01	260206M02		1		
29	DRIER		462965-01	1	-		
			P02070-01		1		
30	PUSH MOUNT TIE		436156-02	1	1		
31	COPPER TUBE (D1) - HIGH SIDE	COPPER TUBE (D) - HIGH SIDE 374039G01	374039M01	1	1		
33	ELBOW		417395-03	1	1		
34	STRAINER	COPPER TUBE (D) - HIGH SIDE 374039G01	P00812-01	1	1		
36	ACCESS VALVE		457729-01	2	1		
37	VALVE BODY		4A3978-01	1	1		
38	COIL-VALVE		P00810-01	1	1		
39	BOLT		P00811-01	1	1		
40	TRUSS HEAD SCREW		FST0408S0	2	2		



GENERAL

MODEL: <b>KMD-270AA</b>				TITLE: <b>B. REFRIGERATION CIRCUIT</b>			
INDEX NO.	DESCRIPTION	MATERIAL OR MODEL NUMBER	PART NUMBER	REQ'D NUMBER			
				V-1,A-1	A-2		
41	COPPER TUBE (E1) - HOT GAS	COPPER TUBE (E) - HOT GAS 371883G01	371878M01	1	1		
42	COPPER TUBE (E2) - HOT GAS	COPPER TUBE (E) - HOT GAS 371883G01	371880M01	1	1		
43	TEE	COPPER TUBE (E) - HOT GAS 371883G01	420335-01	1	1		
44	INSULATION TUBE	COPPER TUBE (E) - HOT GAS 371883G01 7762-1030 L=290	H71030290	1	1		
45	INSULATION TUBE	COPPER TUBE (E) - HOT GAS 371883G01 7762-1020 L=360	H71020360	1	1		
46	EXPANSION VALVE		4A1414-01	1	1		
47	EXPANSION VALVE COVER		3A0944-01	1	1		
48	HEAT EXCHANGER		258736G01	1	1		
49	THERMISTOR		P00027-01	1	1		
50	HOLDER - THERMISTOR		427430-01	1	1		
51	HOLDER / EXP. VALVE - 3/8		3A0107-01	1	1		
52	CLAMP		443461-02	1	1		
53	COPPER TUBE (F1) - ACCESS VALVE	COPPER TUBE (F) - ACCESS VALVE 374038G01	374038M01	1	1		
54	TEE 6.4	COPPER TUBE (F) - ACCESS VALVE 374038G01	417394-01	1	1		
55	COPPER TUBE (F2) - ACCESS VALVE	COPPER TUBE (F) - ACCESS VALVE 374038G01	374038M02	1	1		

GENERAL

MODEL: <b>KMD-270AA</b>		TITLE: <b>B. REFRIGERATION CIRCUIT</b>					
INDEX NO.	DESCRIPTION	MATERIAL OR MODEL NUMBER	PART NUMBER	REQ'D NUMBER			
				V-1,A-1	A-2		
56	EVAPORATOR ASSY		258740G01	1	1		
57	BAG		4X1559-01	1	1		
58	RUBBER INSULATION (B)		3A1045-01	1	1		
59	RUBBER INSULATION (A)		3A1044-01	1	1		
60	INSULATION HOLDER		473043M01	1	1		
61	T2 SCREW	4X8 SUS	FT20408M0	6	6		
62	INSULATION - THERMISTOR (A)		439368-01	1	1		
63	INSULATION - THERMISTOR (B)		439368-02	1	1		
64	INSULATION TUBE	7762-1020 L=90	H71020090	1	1		

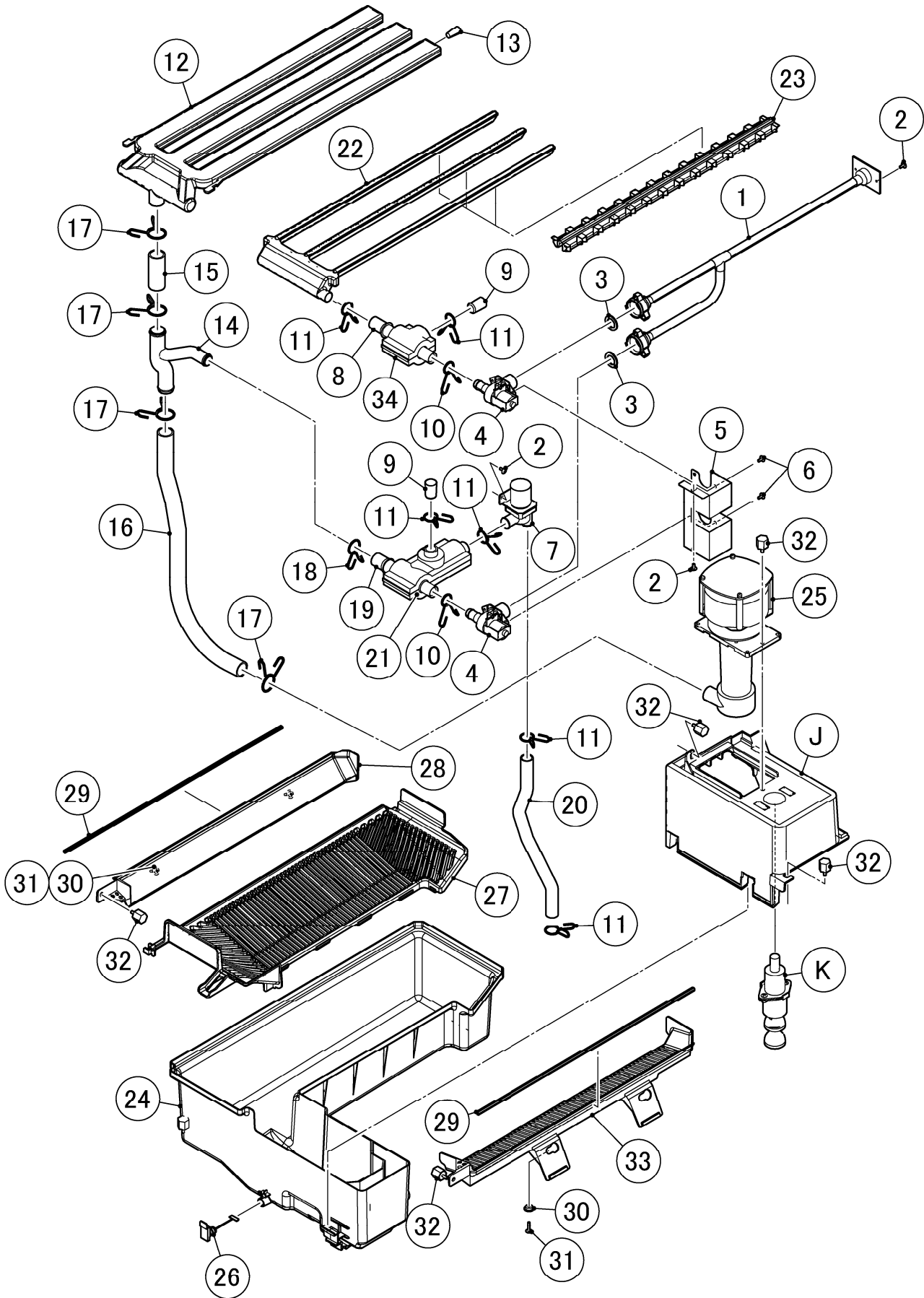

GENERAL

MODEL: <b>KMD-270AA</b>		TITLE: <b>C. WATER CIRCUIT ASSY</b>					
INDEX NO.	DESCRIPTION	MATERIAL OR MODEL NUMBER	PART NUMBER	REQ'D NUMBER			
				V-1,A-1	A-2		
J	PUMP BRACKET ASSY		374040A01	1	1		
K	FLOAT SWITCH ASSY		373885A01	1	1		
1	WATER SUPPLY PIPE		371882G01	1	1		
2	T2 SCREW	4X8	FT20408F0	5	5		
3	RUBBER GASKET		413854-03	2	2		
4	WATER VALVE		P00805-01	2	2		
5	WATER VALVE BRACKET		371875G01	1	1		
6	TRUSS HEAD SCREW	4X8 SUS	FST0408S0	4	4		
7	SOLENOID VALVE	FDC-90-02-220	P00018-01	1	1		
8	TEE		371167R01	1	1		
9	PLUG		472567P01	2	2		
10	HOSE CLAMP	16.5mm SUS	P02909-04	2	2		
11	HOSE CLAMP	18mm SUS	P02909-05	6	6		
12	SPRAY TUBE		255256P01	1	1		
13	PLUG		4A0176-01	3	3		
14	CONNECTING PIPE		371162P01	1	1		
15	SILICONE HOSE	Φ20XΦ25(CLEAR) L=60	H12025060	1	1		
16	SILICONE HOSE	Φ20XΦ25(CLEAR) L=465	H12025465	1	1		
17	HOSE CLAMP	25mm SUS	P02909-03	4	4		
18	HOSE CLAMP	20mm SUS	P02909-06	1	1		
19	BYPASS HOSE		371165R01	1	1		
20	SILICONE HOSE	Φ15XΦ19(CLEAR) L=340	H11519340	1	1		
21	BYPASS INSULATION		371169Z01	1	1		
22	WATER SUPPLY TUBE		255255P01	1	1		
23	SPRAY GUIDE		258313P05	3	3		
24	WATER TANK		120463P01	1	1		
25	PUMP MOTOR		P00818-01	1	1		

GENERAL

MODEL: <b>KMD-270AA</b>		TITLE: <b>C. WATER CIRCUIT ASSY</b>					
INDEX NO.	DESCRIPTION	MATERIAL OR MODEL NUMBER	PART NUMBER	REQ'D NUMBER			
				V-1,A-1	A-2		
26	DRAIN CAP		371168G01	1	1		
27	CUBE GUIDE		118904P01	1	1		
28	DEFLECTOR (L)		255250P01	1	1		
29	GASKET		371166R01	2	2		
30	COLLAR		435269-01	4	4		
31	T2 SCREW	4X16 SUS	FT20416M0	4	4		
32	THUMBSCREW		415949G12	5	5		
33	DEFLECTOR (R)		258596P01	1	1		
34	INLET INSULATION		373079Z01	1	1		

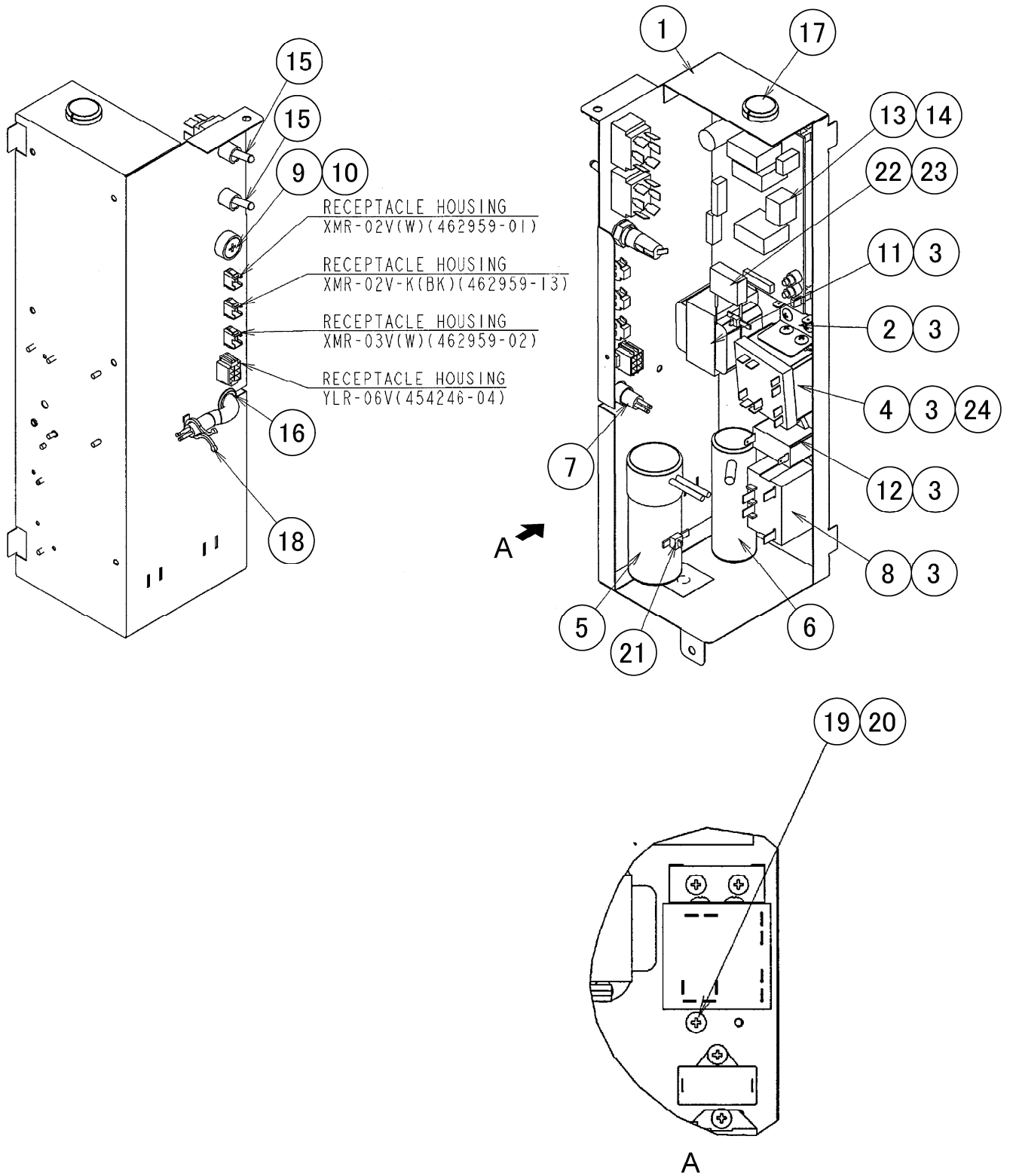

GENERAL

MODEL: <b>KMD-270AA</b>		TITLE: <b>D. CONTROL BOX ASSY</b>					
INDEX NO.	DESCRIPTION	MATERIAL OR MODEL NUMBER	PART NUMBER	REQ'D NUMBER			
				V-1,A-1	A-2		
1	CONTROL BOX		255970M01	1	1		
2	BRACKET - STARTER		474966M01	1	1		
3	T2 SCREW		FT20408F0	9	9		
4	STARTING RELAY		P01826-01	1	1		
5	START CAPACITOR		P01827-01	1	1		
6	RUN CAPACITOR		P01828-01	1	1		
7	WIRE KIT		P01829-01	1	1		
8	POWER RELAY	G7L-1A-TUB	P00034-01	1	1		
9	FUSE HOLDER	BF115	P00014-01	1	1		
10	FUSE	125/250V 5A	P00015-01	1	1		
11	TRANSFORMER	DB48-26	P00012-01	1	1		
12	CAPACITOR	CMPS45B105UWF	P00850-01	1	1		
13	CONTROLLER BOARD	HKM2006V003	P01771-02	1	1		
14	BOARD SUPPORT	CBS-9K	P01770-01	4	4		
15	TOGGLE SWITCH	2GM91-78	P01206-01	2	2		
16	BUSHING	OCB-625	428394-03	1	1		
17	BUSHING	SR-34-2	420472-05	1	1		
18	CLAMP	No.249	427902-03	1	1		
19	SPRING WASHER	SUS 4	FWSP04S0	1	1		
20	TRUSS HEAD SCREW	SUS 4X8	FST0408S0	1	1		
21	TIE	CV-200	7920-0010	1	1		
22	CAPACITOR	REB474	P00228-01	1	1		
23	TIE	CV-150	7920-0003	1	1		
24	TIE	CV-100	7920-0002	2	2		

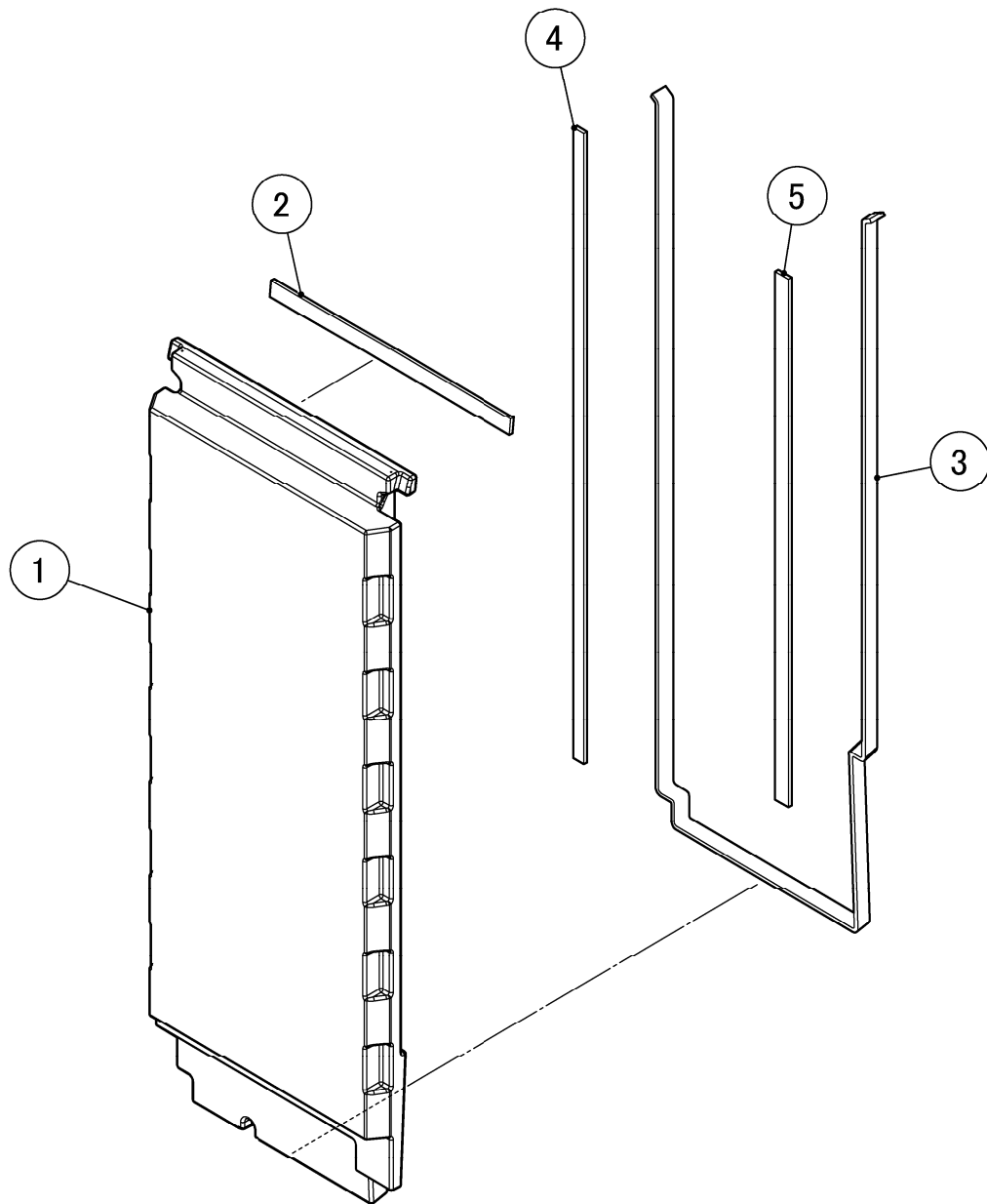



GENERAL

MODEL: <b>KMD-270AA</b>				TITLE: <b>E. FRONT INSULATION ASSY</b>			
INDEX NO.	DESCRIPTION	MATERIAL OR MODEL NUMBER	PART NUMBER	REQ'D NUMBER			
				V-1,A-1	A-2		
1	FRONT INSULATION		255253G02	1	1		
2	GASKET	L=228	371887Z02	1	1		
3	GASKET	L=1385	371887Z03	1	1		
4	GASKET	L=520	371887Z04	1	1		
5	GASKET	L=435	371887Z05	1	1		

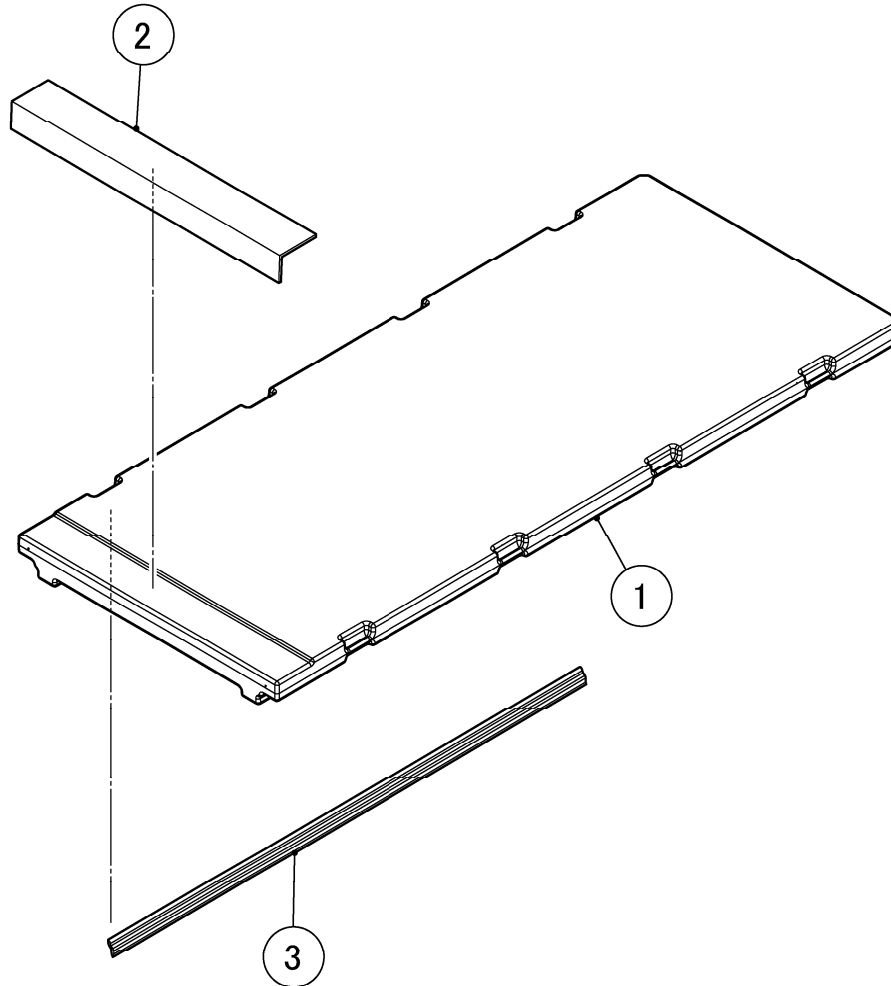

GENERAL

MODEL: <b>KMD-270AA</b>				TITLE: <b>F. TOP INSULATION ASSY</b>			
INDEX NO.	DESCRIPTION	MATERIAL OR MODEL NUMBER	PART NUMBER	REQ'D NUMBER			
				V-1,A-1	A-2		
1	TOP INSULATION		255254G01	1	1		
2	INSULATION		473041Z01	1	1		
3	GASKET	L=415	374537Z03	1	1		

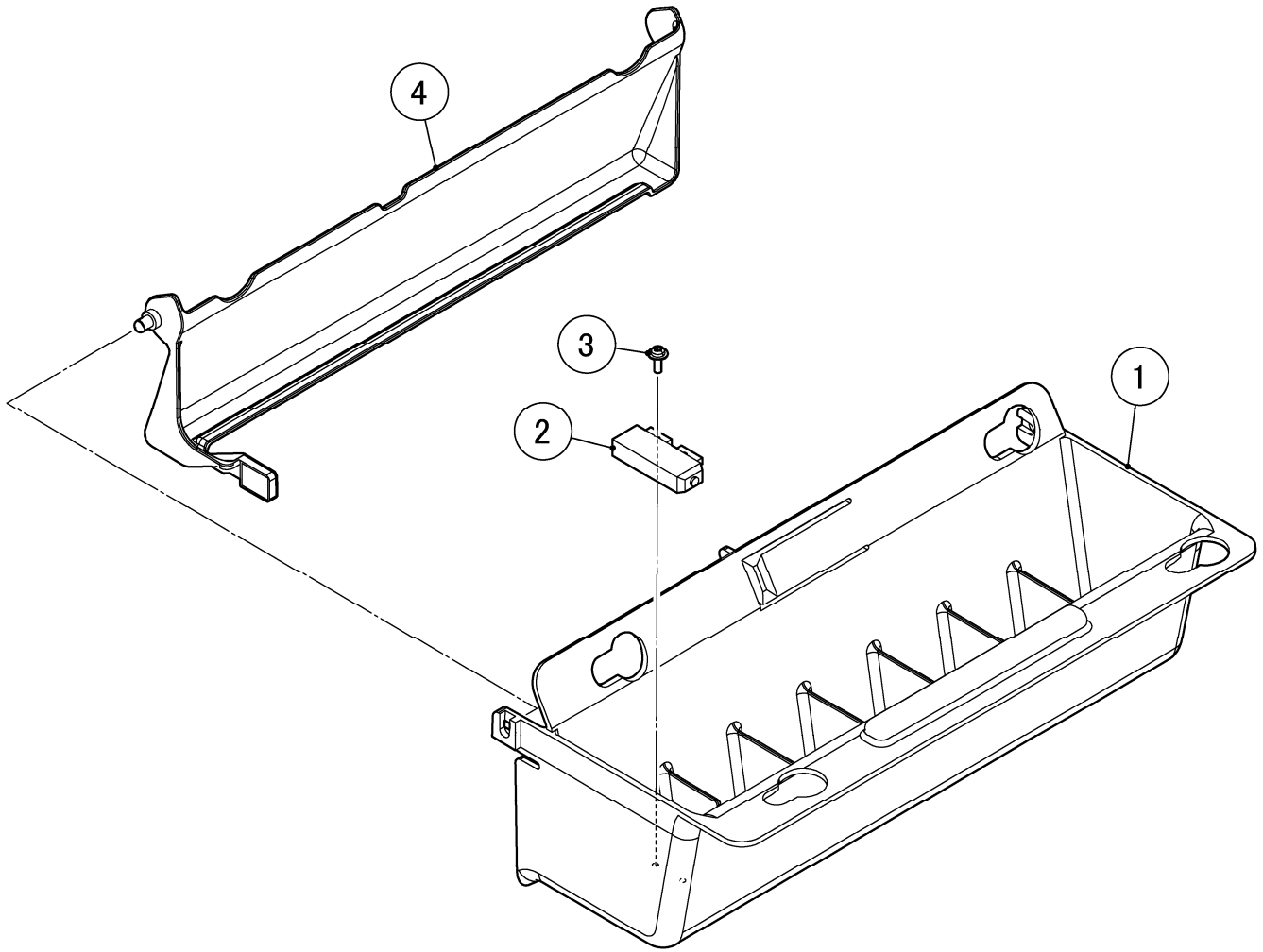

GENERAL

MODEL: <b>KMD-270AA</b>		TITLE: <b>G. BIN SWITCH</b>					
INDEX NO.	DESCRIPTION	MATERIAL OR MODEL NUMBER	PART NUMBER	REQ'D NUMBER			
				V-1,A-1	A-2		
1	SWITCH HOUSING		255248P01	1	1		
2	REED SWITCH	PS-0074-601	453861-04	1	1		
3	TAPPING SCREW	3X8	431415-01	2	2		
4	DETECTOR		371158G01	1	1		

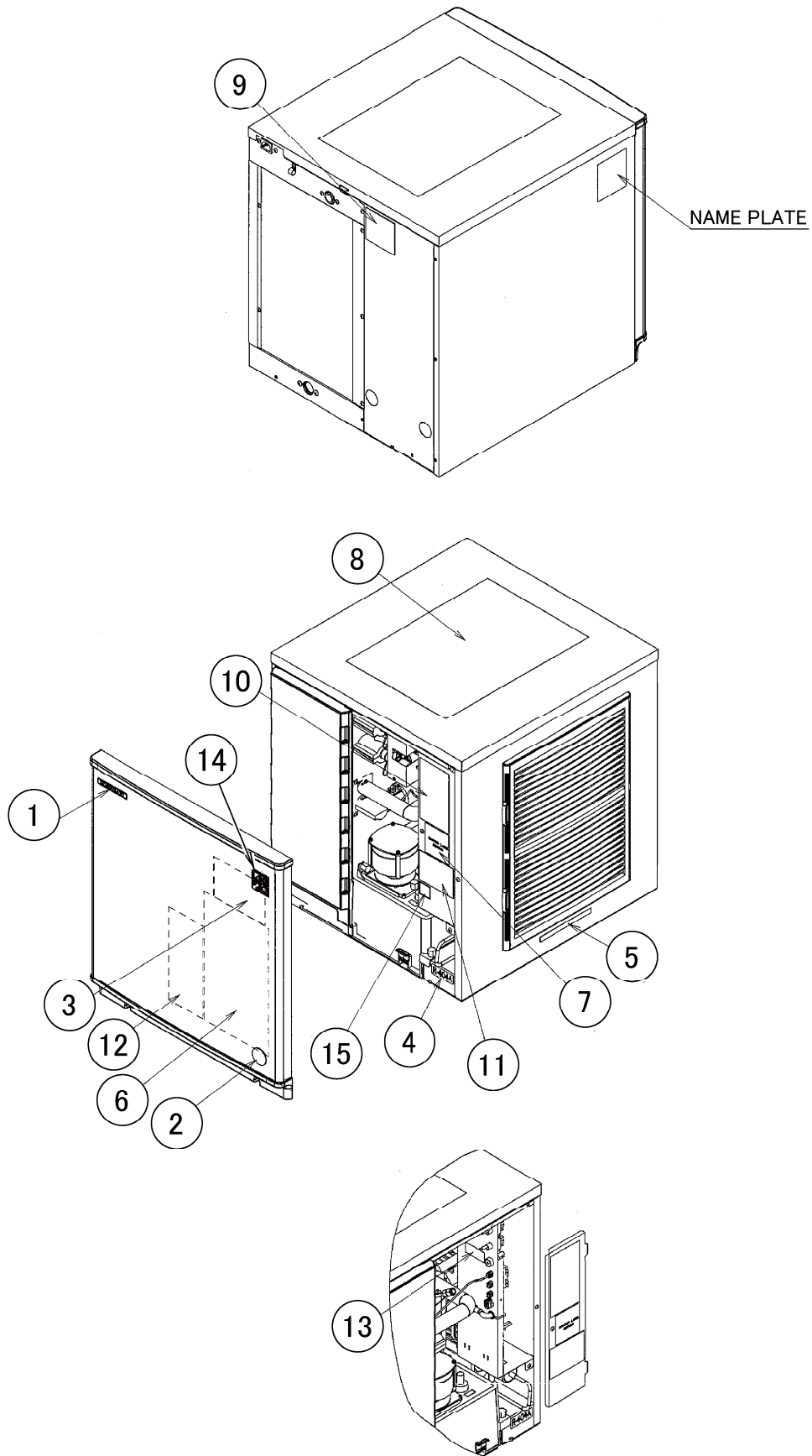



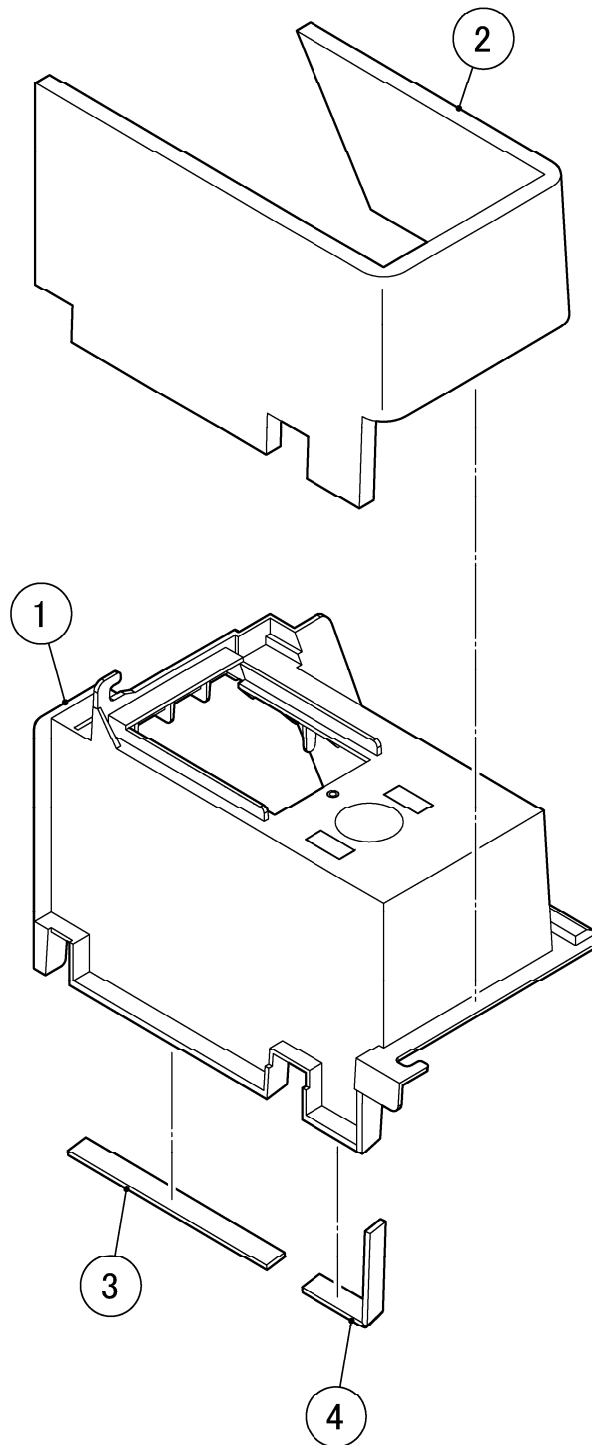



GENERAL

MODEL: <b>KMD-270AA</b>				TITLE: <b>J. PUMP BRACKET ASSY</b>			
INDEX NO.	DESCRIPTION	MATERIAL OR MODEL NUMBER	PART NUMBER	REQ'D NUMBER			
				V-1,A-1	A-2		
1	PUMP BRACKET		120464G01	1	1		
2	PM BRACKET INSULATION		371170Z01	1	1		
3	GASKET	4A0808L02 L=138	374040Z01	1	1		
4	GASKET	4A0808L02 L=100	374040Z02	1	1		

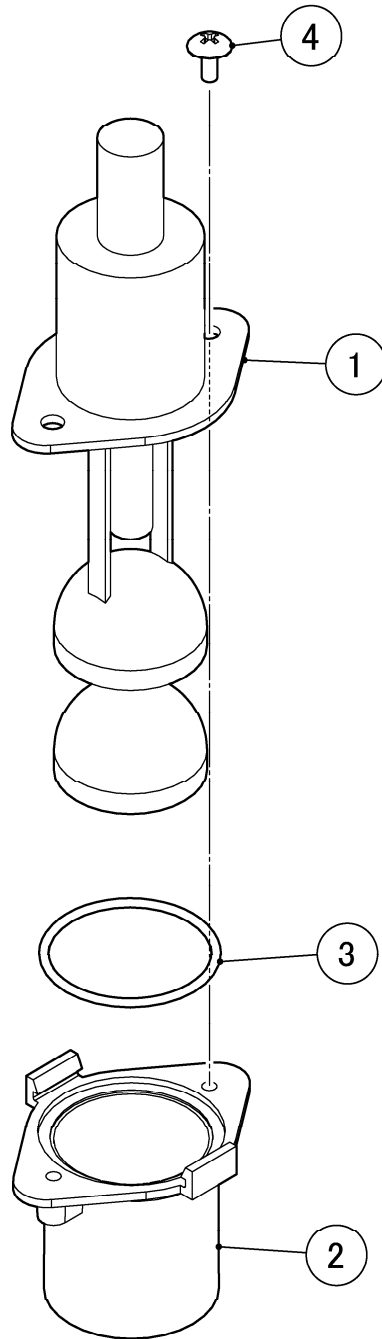

GENERAL

MODEL: <b>KMD-270AA</b>		TITLE: <b>K. FLOAT SWITCH ASSY</b>					
INDEX NO.	DESCRIPTION	MATERIAL OR MODEL NUMBER	PART NUMBER	REQ'D NUMBER			
				V-1,A-1	A-2		
1	FLOAT SWITCH		P00816-01	1	1		
2	BRACKET - FLOAT SWITCH		258597P01	1	1		
3	PACKING		474862R01	1	1		
4	T2 SCREW		FT20408S0	2	2		

