

No.	F022-3207
ISSUED:	Apr. 7, 2009
REVISED:	Nov. 26, 2013



**HOSHIZAKI**  
**MODULAR CRESCENT CUBER**  
**MODEL KMD-201AWA**

**PARTS LIST**  
(GENERAL)

U-1 APR. 2009  
V-0 JAN. 2010  
V-1 FEB. 2010  
V-2 JUL. 2010  
A-0 JAN. 2011  
A-1 APR. 2011

## AUXILIARY CODE

U - 1

The auxiliary code is the first two characters in the serial number. The first character indicates the production year. Years progress or regress in alphabetical order. The series of letters and skipped letters depend on UL listing, production, and model. See the auxiliary code(s) and corresponding year(s) on the front cover.

The second character indicates significant part changes within the same year. Base is "1" and this number advances for each change. If there is no significant part change at the turn of the year, this number starts from "0."

## MARKS LOCATED UNDER THE AUXILIARY CODE

- = Part deleted.
- x = Part deleted and replaced by "o" part.
- o = New part in place of "x" part.

## FASTENER PART NUMBER

### SCREWS

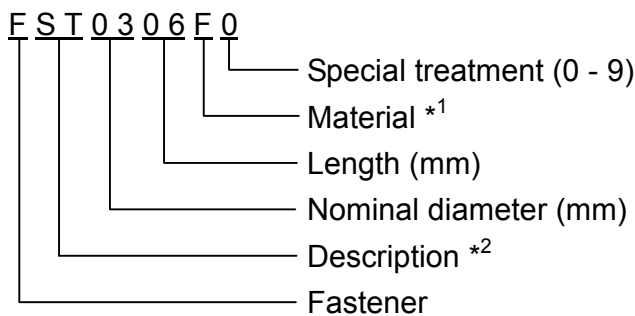

\*<sup>1</sup> Material

- F: Steel
- S: Austenitic stainless steel
- M: Martensitic stainless steel
- B: Copper alloy
- P: Polycarbonate
- N: Polyamide
- V: PVC
- A: ABS
- X: Polyacetal
- L: Aluminum

### NUTS & WASHERS

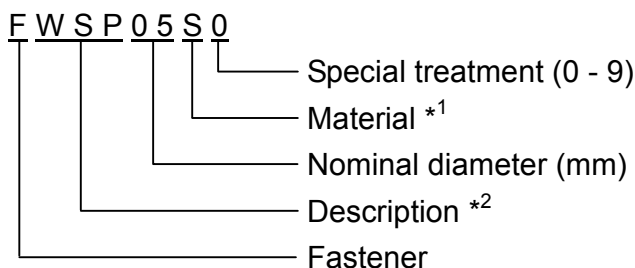

\*<sup>2</sup> Description

- First letter
- S: Machine screw
- T: Tapping screw
- M: Wood screw
- B: Bolt
- W: Washer
- N: Nut

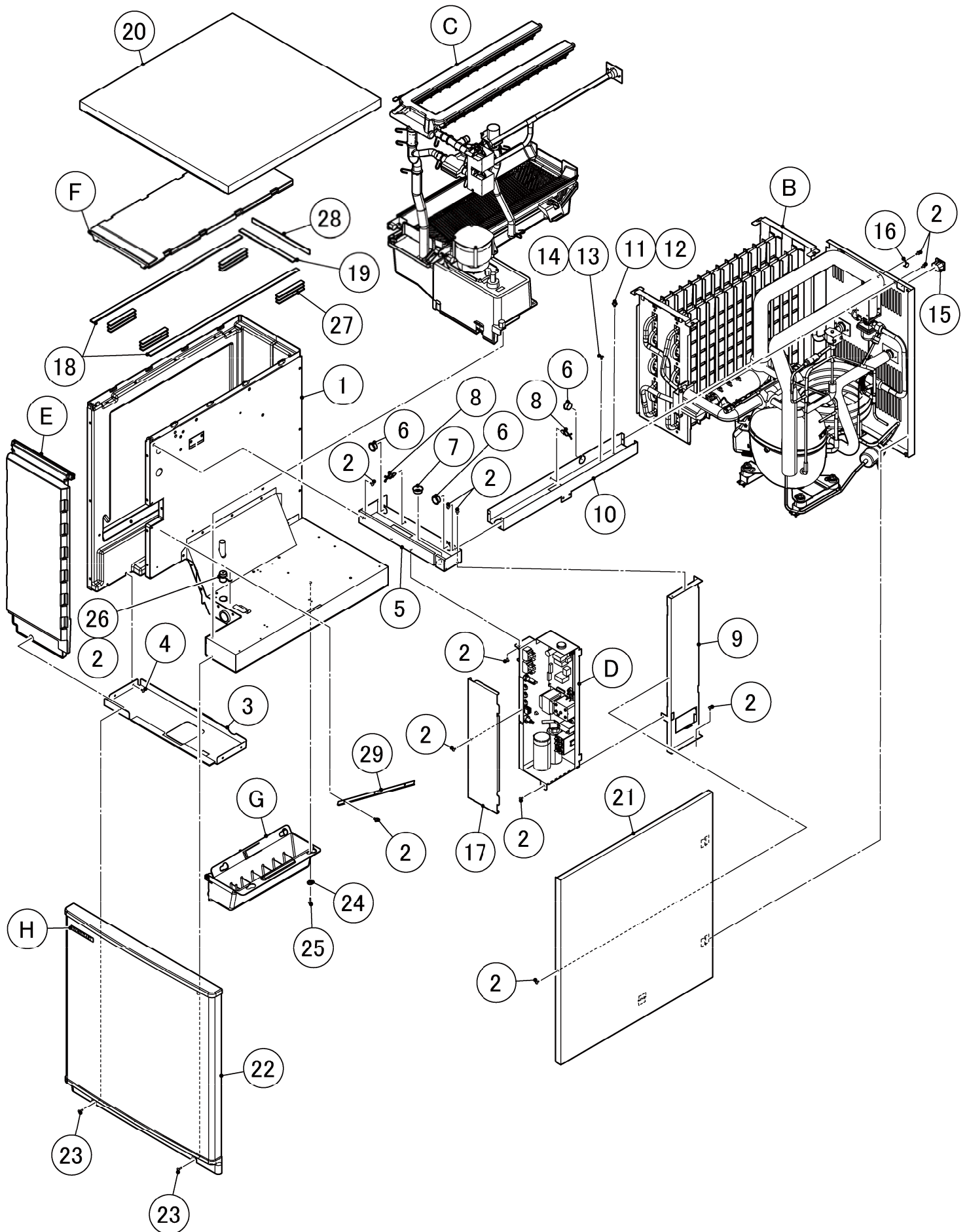

GENERAL

MODEL: <b>KMD-201AWA</b>				TITLE: <b>A. ICE CUBER ASSY</b>			
INDEX NO.	DESCRIPTION	MATERIAL OR MODEL NUMBER	PART NUMBER	REQ'D NUMBER			
				U-1,V-0	V-1	V-2,A-0	A-1
B	REFRIGERATION CIRCUIT		119446A01	1	1	1	1
C	WATER CIRCUIT	50Hz	119593A01	1	1	1	1
		60Hz	119593A02	1	1	1	1
D	CONTROL BOX ASSY		255978A01	1	1	1	1
E	FRONT INSULATION ASSY		371887A01	1	1	1	1
F	TOP INSULATION ASSY		374537A01	1	1	1	1
G	BIN SWITCH		371886A01	1	1	1	1
H	LABEL LOCATION	50Hz	119447A01	1	1	1	1
		60Hz	119447A02	1	1	1	1
K	ACCESSORIES		A01661-01	1	1	1	1
1	EVAP. CASE		119110G02	1	1	1	1
2	T2 SCREW	4X8	FT20408F0	16	16	16	19
3	BOTTOM FRAME		371876M01	1	1	1	1
4	T2 SCREW	4X8 SUS	FT20408M0	4	4	4	4
5	TOP FRAME		371867M01	1	1	1	1
6	BUSHING	OCB-875	428394-04	3	3	3	3
7	BUSHING	OCB-750	428394-01	1	1	1	1
8	CLAMP	No.249	427902-03	2	2	3	3
9	SIDE FRAME (A)		371873M01	1	1	1	1
10	SIDE FRAME (B)		371866M01	1	1	1	1
11	SPRING WASHER	SUS 5	FWSP05S0	1	1	1	1
12	TRUSS HEAD SCREW	SUS 5X8	FST0508S0	1	1	1	1
13	SPRING WASHER	SUS 4	FWSP04S0	1	1	1	1
14	TRUSS HEAD SCREW	SUS 4X8	FST0408S0	1	1	1	1
15	CONNECTOR		P02656-01	1	1	1	1
16	CLAMP	NK-6N	418814-06	1	1	1	1
17	CONT. BOX COVER		371874M01	1	1	1	1

GENERAL

MODEL: <b>KMD-201AWA</b>		TITLE: <b>A. ICE CUBER ASSY</b>					
INDEX NO.	DESCRIPTION	MATERIAL OR MODEL NUMBER	PART NUMBER	REQ'D NUMBER			
				U-1,V-0	V-1	V-2,A-0	A-1
18	GASKET	L=563	119448Z01	2	2	2	2
19	GASKET	L=203	119448Z02	1	1	1	1
20	TOP PANEL		255967M01	1	1	1	1
21	SIDE PANEL (R)		255966G02	1	1	1	1
22	FRONT PANEL		255965G01	1	1	1	1
23	TRUSS HEAD SCREW	4X12 SUS	FST0412S0	2	2	2	2
24	COLLAR		435269-01	4	4	4	4
25	T2 SCREW	4X16 SUS	FT20416M0	4	4	4	4
26	HOLE PLUG		373078R01	1	1	1	1
27	GASKET	L=50	119448Z03	12	12	12	12
28	GASKET	L=215	119448Z04	1	1	1	1
29	PLATE - SIDE PANEL		379577M01				1

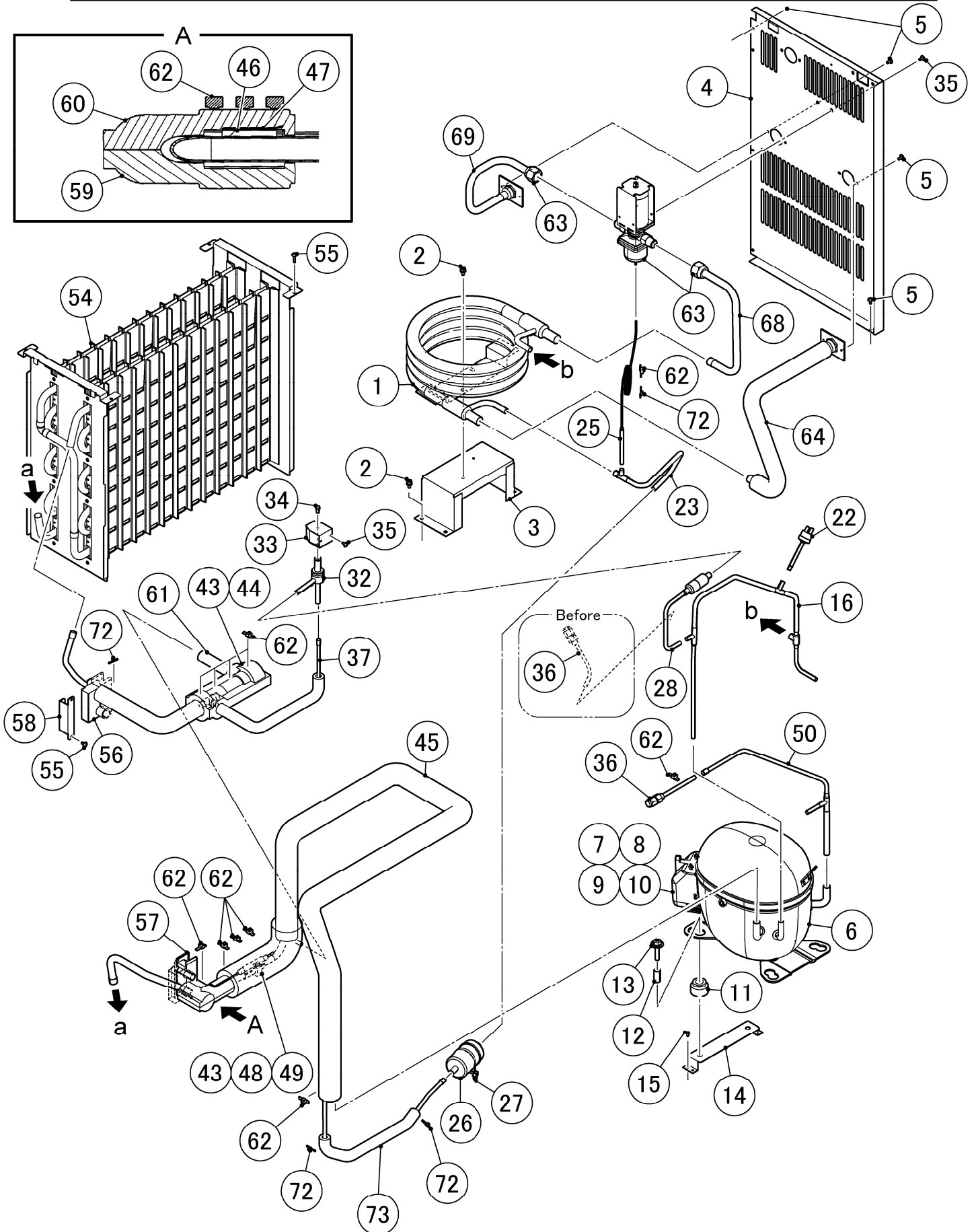

GENERAL

MODEL: <b>KMD-201AWA</b>				TITLE: <b>B. REFRIGERATION CIRCUIT</b>			
INDEX NO.	DESCRIPTION	MATERIAL OR MODEL NUMBER	PART NUMBER	REQ'D NUMBER			
				U-1,V-0	V-1	V-2,A-0	A-1
1	CONDENSER - WATER COOLED		P01212-01	1	1	1	1
2	HEX HEAD BOLT W/WASHER [SW]	5X10 SUS	FBK0510S0	6	6	6	6
3	BASE - CONDENSER WATER COOLED		372520M01	1	1	1	1
4	REAR PANEL		256723M01	1	1	1	1
5	T2 SCREW	4X8	FT20408F0	9	9	9	9
6	COMPRESSOR	NT6217GK	P00835-01	1	1	1	1
7	TERMINAL COVER		P02814-01	1	1	1	1
8	PROTECTOR	T0817/G9	P00838-01	1	1	1	1
9	PROTECTOR RETAINER		P02815-01	1	1	1	1
10	SCREW		P00840-01	1	1	1	1
11	GROMMET		P00846-01	4	4	4	4
12	SPACER		P00847-01	4	4	4	4
13	BOLT	M8X35	436206-03	4	4	4	4
14	COMP. MOUNT		371868G01	2	2	2	2
15	RIVET	SSD43SSBS	7170-0005	8	8	8	8
16	COPPER TUBE (A1) - HIGH SIDE	COPPER TUBE (A) - HIGH SIDE 256728G01	256728M01	1	1	1	1
17	COPPER TUBE (A2) - HIGH SIDE	COPPER TUBE (A) - HIGH SIDE 256728G01	256728M02	1	1	1	1
18	COPPER TUBE (A3) - HIGH SIDE	COPPER TUBE (A) - HIGH SIDE 256728G01	256728M03	1	1	1	1
19	COPPER TUBE (A4) - HIGH SIDE	COPPER TUBE (A) - HIGH SIDE 256728G01	256728M04	1	1	1	1
20	TEE	COPPER TUBE (A) - HIGH SIDE 256728G01	420041-02	2	2	2	2
21	TEE	COPPER TUBE (A) - HIGH SIDE 256728G01	420041-16	1	1	1	1

GENERAL

MODEL: <b>KMD-201AWA</b>				TITLE: <b>B. REFRIGERATION CIRCUIT</b>			
INDEX NO.	DESCRIPTION	MATERIAL OR MODEL NUMBER	PART NUMBER	REQ'D NUMBER			
				U-1,V-0	V-1	V-2,A-0	A-1
22	PRESSURE SWITCH	ACB-1UB43	463180-05	1	1	1	1
23	COPPER TUBE (B1) - HIGH SIDE	COPPER TUBE (B) - HIGH SIDE 372527G01	372527M01	1	1	1	1
24	TEE	COPPER TUBE (B) - HIGH SIDE 372527G01	4A1545-02	1	1	1	1
25	COPPER TUBE (B) - CAPILLARY		446047-02	1	1	1	1
26	DRIER	DML032.5s	462965-01	1	1	1	-
		DML032S	P02070-01				1
27	PUSH MOUNT TIE	T50RSF	436156-02	1	1	1	1
28	COPPER TUBE (D1) - HIGH SIDE	COPPER TUBE (D) - HIGH SIDE 374039G02	374039M03	1	1	1	1
30	STRAINER	COPPER TUBE (D) - HIGH SIDE 374039G02	P00812-01	1	1	1	1
32	VALVE BODY	ATS-B7SHDU-2	4A3978-01	1	1	1	1
33	COIL-VALVE	AMS-C23HD-2	P00810-01	1	1	1	1
34	BOLT	M4X8	P00811-01	1	1	1	1
35	TRUSS HEAD SCREW	4X8 SUS	FST0408S0	4	4	4	4
36	ACCESS VALVE	TCJ-2F20NHDU-1	457729-01	2	2	2	1
37	COPPER TUBE (E1-1) - HOT GAS	COPPER TUBE (E) - HOT GAS 371883G03	372522M01	1	1	1	1
38	COPPER TUBE (E1-2) - HOT GAS	COPPER TUBE (E) - HOT GAS 371883G03	372522M02	1	1	1	1
39	COPPER TUBE (E2) - HOT GAS	COPPER TUBE (E) - HOT GAS 371883G03	371880M01	1	1	1	1
40	TEE	COPPER TUBE (E) - HOT GAS 371883G03	420335-01	1	1	1	1



GENERAL

MODEL: <b>KMD-201AWA</b>				TITLE: <b>B. REFRIGERATION CIRCUIT</b>			
INDEX NO.	DESCRIPTION	MATERIAL OR MODEL NUMBER	PART NUMBER	REQ'D NUMBER			
				U-1,V-0	V-1	V-2,A-0	A-1
41	INSULATION TUBE	COPPER TUBE (E) - HOT GAS 371883G03 L=290	7762-1030	1	1	1	1
42	INSULATION TUBE	COPPER TUBE (E) - HOT GAS 371883G03 L=360	7762-1020	1	1	1	1
43	EXP. VALVE	HFE-10NHD-2	4A1414-01	1	1	1	1
44	EXPANSION VALVE COVER		3A0944-01	1	1	1	1
45	HEAT EXCHANGER		255974G02	1	1	1	1
46	THERMISTOR	NBFC-36-H60-1	P00027-01	1	1	1	1
47	HOLDER - THERMISTOR		427430-01	1	1	1	1
48	HOLDER / EXP. VALVE - 3/8		3A0107-01	1	1	1	1
49	CLAMP		443461-02	1	1	1	1
50	COPPER TUBE (F1) - ACCESS VALVE	COPPER TUBE (F) - ACCESS VALVE 371877G01	371877M01	1	1	1	1
51	TEE	COPPER TUBE (F) - ACCESS VALVE 371877G01	417394-01	1	1	1	1
52	COPPER TUBE (F2) - ACCESS VALVE	COPPER TUBE (F) - ACCESS VALVE 371877G01	371877M03	1	1	1	1
53	COPPER TUBE (F3) - ACCESS VALVE	COPPER TUBE (F) - ACCESS VALVE 371877G01	371877M04	1	1	1	1
54	EVAPORATOR ASSY		257091G01	1	1	1	1
55	T2 SCREW	4X8 SUS	FT20408M0	6	6	6	6
56	RUBBER INSULATION (B)		3A1045-01	1	1	1	1
57	RUBBER INSULATION (A)		3A1044-01	1	1	1	1
58	INSULATION HOLDER		473043M01	1	1	1	1
59	INSULATION - THERMISTOR (A)		439368-01	1	1	1	1
60	INSULATION - THERMISTOR (B)		439368-02	1	1	1	1
61	INSULATION TUBE	L=90	7762-1020	1	1	1	1

GENERAL

MODEL: <b>KMD-201AWA</b>				TITLE: <b>B. REFRIGERATION CIRCUIT</b>			
INDEX NO.	DESCRIPTION	MATERIAL OR MODEL NUMBER	PART NUMBER	REQ'D NUMBER			
				U-1,V-0	V-1	V-2,A-0	A-1
62	TIE	CV-200	7920-0010	15	15	15	14
63	WATER REGULATOR	WV2-F4NHD-1	P01213-01	1	1	1	1
64	COPPER TUBE (A1) - WATER CIRCUIT	COPPER TUBE (A) - WATER CIRCUIT 372524G01	372524M01	1	1	1	1
65	INLET FITTING	COPPER TUBE (A) - WATER CIRCUIT 372524G01	P01214-01	1	1	1	1
66	FITTING HOLDER	COPPER TUBE (A) - WATER CIRCUIT 372524G01	4A0764-01	1	1	1	1
67	INSULATION TUBE	COPPER TUBE (A) - WATER CIRCUIT 372524G01 L=430	7762-1330	1	1	1	1
68	COPPER TUBE (B) - WATER CIRCUIT		372525M01	1	1	1	1
69	COPPER TUBE (C1) - WATER CIRCUIT	COPPER TUBE (C) - WATER CIRCUIT 372526G01	372526M01	1	1	1	1
70	INLET FITTING	COPPER TUBE (C) - WATER CIRCUIT 372526G01	P01214-01	1	1	1	1
71	FITTING HOLDER	COPPER TUBE (C) - WATER CIRCUIT 372526G01	4A0764-01	1	1	1	1
72	TIE	CV-100	7920-0002	4	4	4	4
73	INSULATION TUBE	L=245	H71020245	1	1	1	1

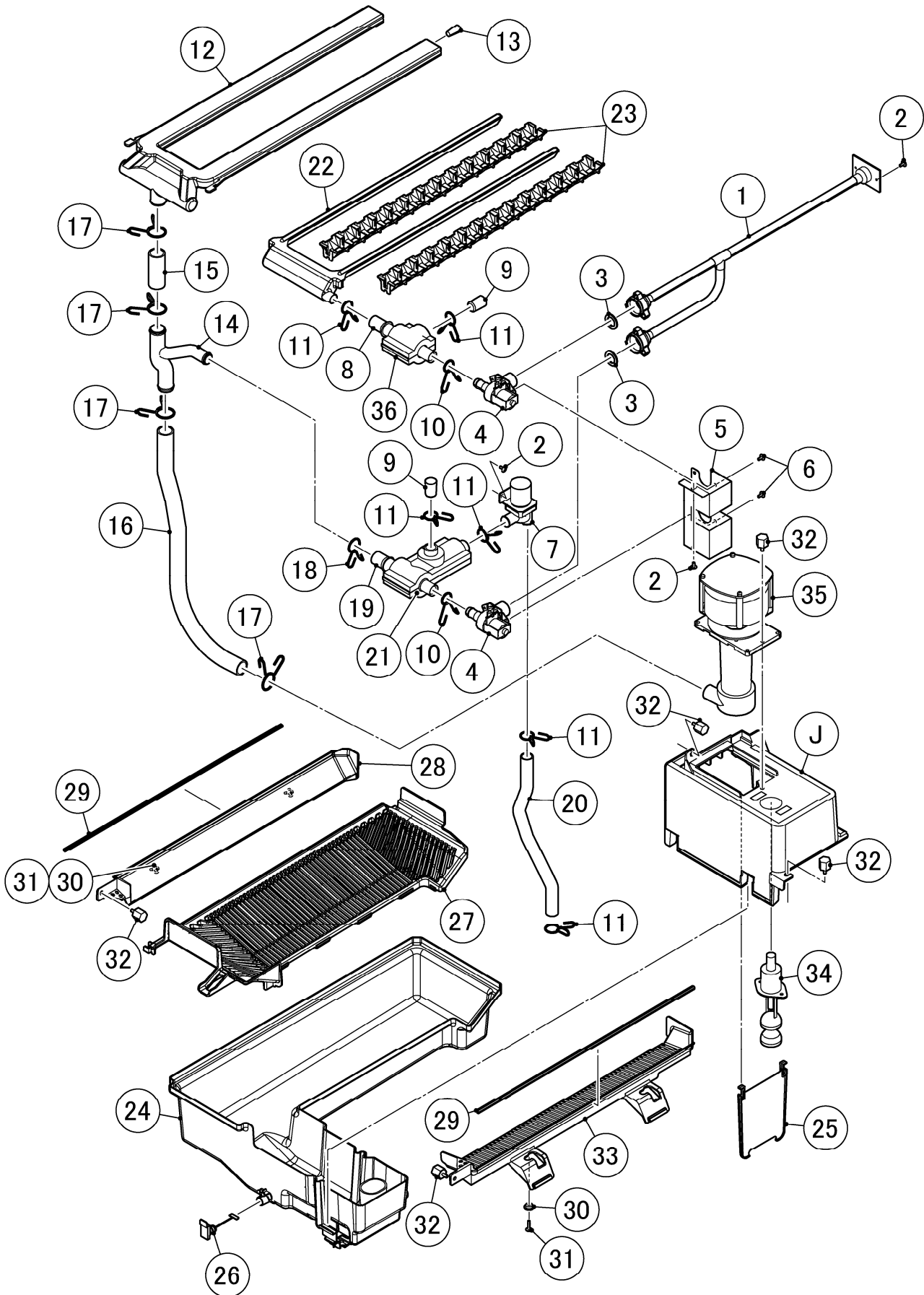

GENERAL

MODEL: <b>KMD-201AWA</b>		TITLE: <b>C. WATER CIRCUIT ASSY</b>					
INDEX NO.	DESCRIPTION	MATERIAL OR MODEL NUMBER	PART NUMBER	REQ'D NUMBER			
				U-1,V-0	V-1	V-2,A-0	A-1
J	PUMP BRACKET ASSY		371889A01	1	1	1	1
1	WATER SUPPLY PIPE		371882G01	1	1	1	1
2	T2 SCREW	4X8	FT20408F0	5	5	5	5
3	RUBBER GASKET		413854-03	2	2	2	2
4	WATER VALVE	V19 4L/min	P00806-01	2	2	2	2
5	WATER VALVE BRACKET		371875G01	1	1	1	1
6	TRUSS HEAD SCREW	4X8 SUS	FST0408S0	4	4	4	4
7	SOLENOID VALVE	FDC-90-02-220	P00018-01	1	1	1	1
8	TEE		371167R01	1	1	1	1
9	PLUG		472567P01	2	2	2	2
10	HOSE CLAMP	16.5mm SUS	P02909-04	2	2	2	2
11	HOSE CLAMP	18mm SUS	P02909-05	6	6	6	6
12	SPRAY TUBE		256969P01	1	1	1	1
13	PLUG		4A0176-01	2	2	2	2
14	CONNECTING PIPE		371162P02	1	1	1	1
15	SILICONE HOSE	φ20Xφ25(CLEAR)L=60	H12025060	1	1	1	1
16	SILICONE HOSE	φ20Xφ25(CLEAR)L=465	H12025465	1	1	1	1
17	HOSE CLAMP	25mm SUS	P02909-03	4	4	4	4
18	HOSE CLAMP	20mm SUS	P02909-06	1	1	1	1
19	BYPASS HOSE		371165R01	1	1	1	1
20	SILICON HOSE	φ15Xφ19(CLEAR)L=340	H11519340	1	1	1	1
21	BYPASS INSULATION		371169Z01	1	1	1	1
22	WATER SUPPLY TUBE		256968P01	1	1	1	1
23	SPRAY GUIDE		252052P03	2	2	2	2
24	TANK		255326G02	1	1	1	1
25	PARTITION PLATE		371160P01	1	1	1	1
26	DRAIN CAP		371168G01	1	1	1	1

GENERAL

MODEL: <b>KMD-201AWA</b>		TITLE: <b>C. WATER CIRCUIT ASSY</b>					
INDEX NO.	DESCRIPTION	MATERIAL OR MODEL NUMBER	PART NUMBER	REQ'D NUMBER			
				U-1,V-0	V-1	V-2,A-0	A-1
27	CUBE GUIDE		118904P01	1	1	1	1
28	DEFLECTOR (L)		255250P01	1	1	1	1
29	GASKET		371166R01	2	2	2	2
30	COLLAR		435269-01	4	4	4	4
31	T2 SCREW	4X16 SUS	FT20416M0	4	4	4	4
32	THUMBSCREW		415949G12	5	5	5	5
33	DEFLECTOR (R)		255249P01	1	1	1	1
34	FLOAT SWITCH	OLV-29Z-2P2	P00816-01	1	1	1	1
35	PUMP MOTOR	PV-212AHZ1 50Hz	P00818-01	1	1	1	1
		PV-212BHZ1 60Hz	P01067-01	1	1	1	1
36	INLET INSULATION		373079Z01	1	1	1	1

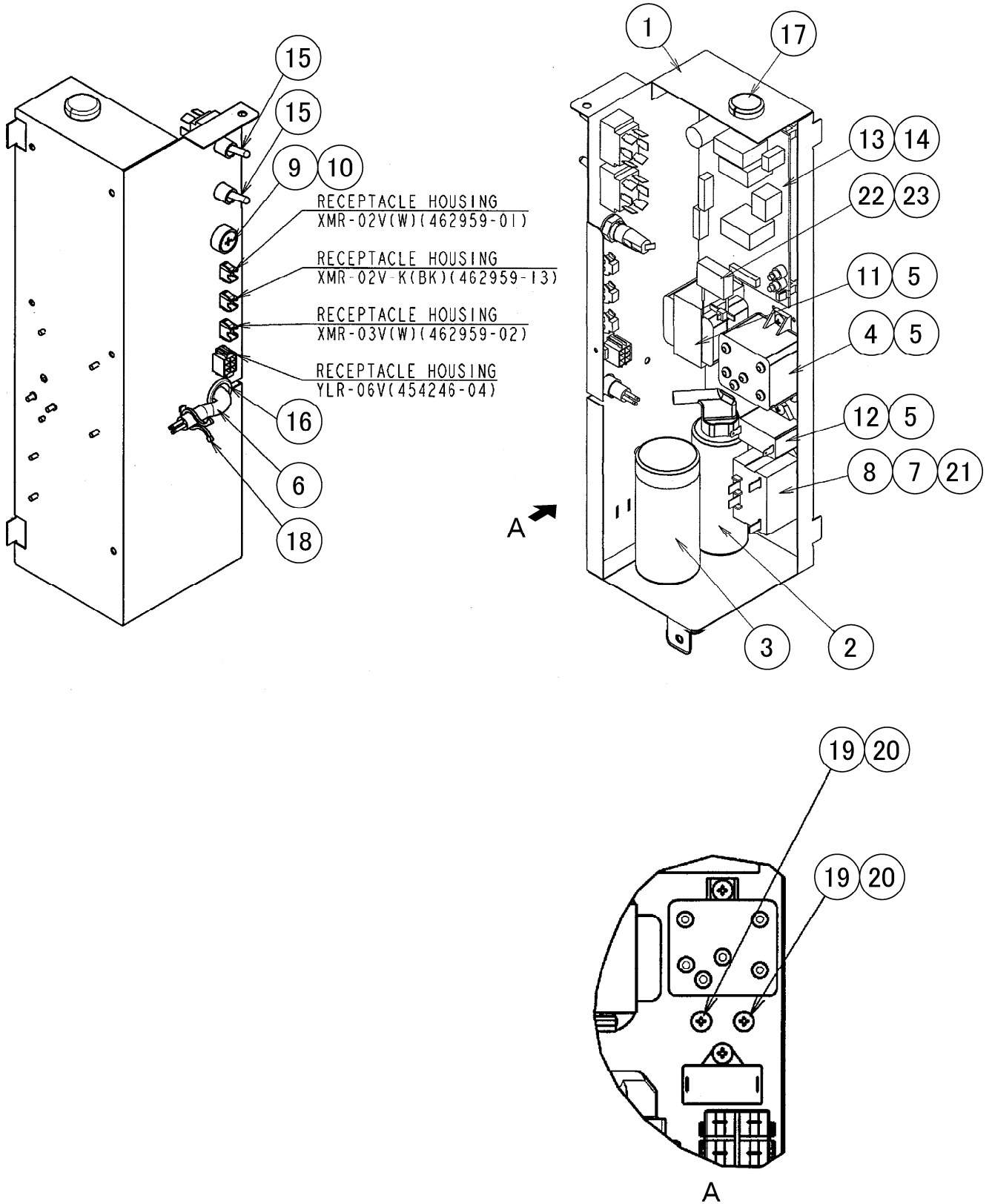

GENERAL

MODEL: <b>KMD-201AWA</b>				TITLE: <b>D. CONTROL BOX ASSY</b>			
INDEX NO.	DESCRIPTION	MATERIAL OR MODEL NUMBER	PART NUMBER	REQ'D NUMBER			
				U-1,V-0	V-1	V-2,A-0	A-1
1	CONTROL BOX		255970M01	1	1	1	1
2	RUN CAPACITOR	2253311 17.5uF	P02145-01	1	1	1	1
3	START CAPACITOR	2252270 72-88uF	P00844-01	1	1	1	1
4	STARTER	3ARR3B10AB3	P00842-01	1	1	1	1
5	T2 SCREW	4X8	FT20408F0	4	6	6	6
6	WIRE KIT		P00845-01	1	1	1	1
7	PAN HEAD T2 SCREW	4X12	FT50412F0	2	-	-	-
8	MAGNETIC CONTACTOR	FC-0TULAC220VINC	P01694-01	1	-	-	-
9	FUSE HOLDER	BF115	P00014-01	1	1	1	1
10	FUSE	125/250V 5A	P00015-01	1	1	1	1
11	TRANSFORMER	DB48-26	P00012-01	1	1	1	1
12	CAPACITOR	CMPS45B105UWF	P00850-01	1	1	1	1
13	CONTROLLER BOARD		P00013-02	1	1	-	-
		HKM2006V003	P01771-02			1	1
14	BOARD SUPPORT	CBS-9K	P01770-01	4	4	4	4
15	TOGGLE SWITCH	2GM91-78	P01206-01	2	2	2	2
16	BUSHING	OCB-625	428394-03	1	1	1	1
17	BUSHING	SR-34-2	420472-05	1	1	1	1
18	CLAMP	No. 249	427902-03	1	1	1	1
19	SPRING WASHER	SUS 4	FWSP04S0	2	2	2	2
20	TRUSS HEAD SCREW	SUS 4X8	FST0408S0	2	2	2	2
21	POWER RELAY	G7L-1A-TUB	P00034-01		1	1	1
22	CAPACITOR	REB474	P00228-01			1	1
23	TIE	CV-150	7920-0003			1	1

