

Hoshizaki America, Inc.

Stackable Crescent Cuber

Models

KM-130ISAH/3, SWH/3, SRH/3



“A Superior Degree
of Reliability”

www.hoshizaki.com

PARTS LIST



Number: 71290
Issued: 11-25-2008
Revised: 10-20-2014

CONTENTS

Auxiliary Codes.....	3
Note About Ordering Parts	4
A. Main Assembly & Refrigeration Circuit	5
KM-1301SAH/3.....	5
KM-1301SWH/3.....	8
KM-1301SRH/3.....	11
B. Water Circuit	14
C. Control Box Assembly	17
D. Accessories & Labels	19

Auxiliary Codes

KM-1301SAH	T-0	October 2008	KM-1301SAH3	T-0	October 2008
	U-0	January 2009		U-0	February 2009
	U-1	September 2009		U-1	November 2009
	V-0	January 2010		V-0	February 2010
	V-1	June 2010		V-1	June 2010
	V-2	July 2010		V-2	July 2010
	A-0	January 2011		A-0	January 2011
	A-1	November 2011		A-1	November 2011
	B-0	January 2012		B-0	January 2012
	C-0	January 2013		C-0	January 2013
	D-1	January 2014		D-0	January 2014
KM-1301SWH	T-0	September 2008	KM-1301SWH3	T-0	September 2008
	U-0	March 2009		U-0	April 2009
	U-1	September 2009		U-1	November 2009
	V-0	January 2010		V-0	March 2010
	V-1	June 2010		V-2	July 2010
	V-2	July 2010		A-0	February 2011
	A-0	January 2011		B-0	January 2012
	A-1	November 2011		C-0	February 2013
	B-0	January 2012		C-1	February 2013
	C-0	February 2013		D-0	February 2014
	C-1	March 2013			
	D-1	January 2014			
KM-1301SRH	T-0	October 2008	KM-1301SRH3	T-0	October 2008
	U-0	January 2009		U-0	January 2009
	U-1	September 2009		U-1	September 2009
	V-0	January 2010		V-0	January 2010
	V-1	June 2010		V-1	June 2010
	V-2	July 2010		V-2	July 2010
	A-0	January 2011		A-0	January 2011
	A-1	October 2011		A-1	November 2011
	B-0	January 2012		B-0	January 2012
	C-0	January 2013		C-0	January 2013
	D-0	January 2014		D-0	January 2014
	D-1	May 2014			

Auxiliary Code Breakdown

The auxiliary code is the first two characters in the serial number. The first character indicates the year. Years progress or regress in alphabetical order. The series runs from "A" through "V" and the letters "I" and "O" are skipped. The second character indicates significant part changes within a year. Base is "0" and this number advances for each change. In cases where there is a letter in parentheses, this designates the month. This is the last character in the serial number. The series runs from "(A)" through "(M)" and the letter "(I)" is skipped. This designation is only included when identifying a parts change within an auxiliary code.

Note About Ordering Parts

Most assemblies cannot be ordered as complete units; parts in the assemblies generally must be ordered separately.

A. Main Assembly & Refrigeration Circuit

KM-1301SAH/3

T-0 to D-1

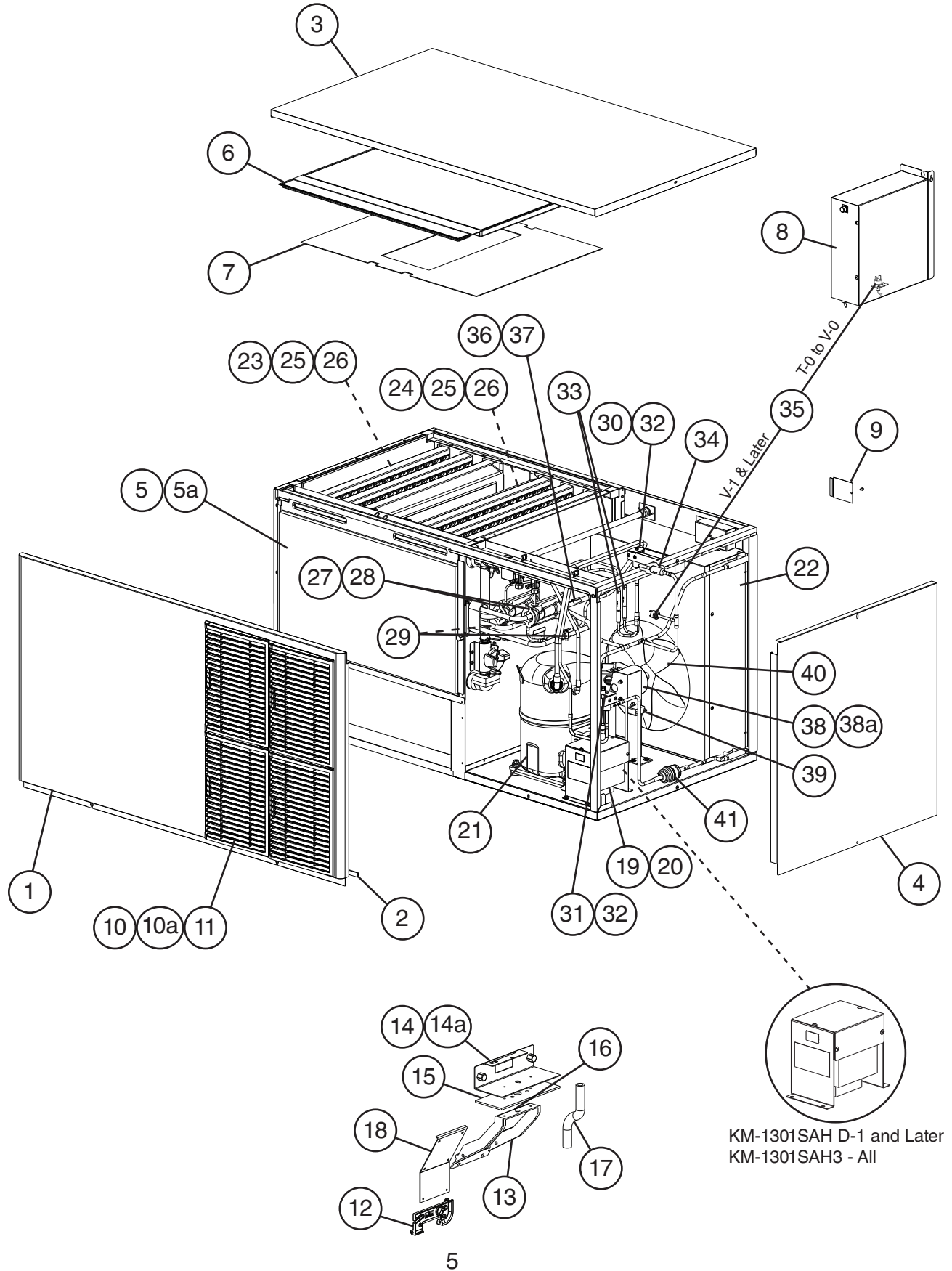

Title: A. Ice Cuber Assembly & Refrigeration Circuit Model: KM-1301SAH/3												
Index No.	Description	Material or Model Number	Part Number	Required Number								
				T-0 U-0	U-1 V-0	V-1 to A-0	A-1 to D-0	D-1				
Main Assembly												
1	Front Panel		2A2224-02	1	1	1	1	1				
2	Gasket	L=1219 mm	4A0808L02	1	1	1	1	1				
3	Top Panel		2A2255-01	1	1	1	1	1				
4	Right Side Panel		2A2226G01	1	1	1	1	1				
5	Front Insulation		324215G01	1	1	1	1	1				
5a	Thumbscrew		415949G12	1	1	1	1	1				
6	Top Insulation		324216G01	1	1	1	1	1				
7	Spacer		324321-01	1	1	1	1	1				
8	Control Box Cover		3A2386-01	1	1	1	1	1				
9	Junction Box Cover		433410-01	1	1	1	1	1				
10	Louver		1A0548-01	4	4	4	4	4				
10a	Push Retainer		4A2414-01	12	12	12	12	12				
11	Air Filter		2A2063G01	4	4	4	4	4				
12	Bin Control Bulb Holder		3A3903-01	1	1	1	1	1				
13	Bin Control Bulb Holder C		216340G01	1	1	1	1	1				
14	Bin Control Bulb Holder D		328742-01	1	1	1	1	1				
14a	Thumbscrew		415949G12	2	2	2	2	2				
15	Spacer		439727-01	1	1	1	1	1				
16	Capillary Ring		425307-01	1	1	1	1	1				
17	Silicone Hose	L=285 mm	773013812	1	1	1	1	1				
18	Bin Control Extension Bracket		3A0408-01	1	1	1	1	1				
19	Main Transformer	KM-1301SAH	4A5695-01					1				
				KM-1301SAH3	1	1	1	1	1			
20	Voltage Tap Switch	KM-1301SAH	4A1477-01					1				
				KM-1301SAH3	1	1	1	1	1			
Refrigeration Circuit												
21	Compressor	KM-1301SAH	4A1412-01	1	1	1	-					
			4A1412-03				1	1				
		KM-1301SAH3	4A1484-01	1	1	1	-					
			4A1484-03				1	1				
22	Condenser		213621-01	1	1	1	1	1				
23	Left Evaporator Bank (includes 3 of item 25)	HS-0208	2A0414G02	1	1	1	1	1				
24	Right Evaporator Bank (includes 3 of item 25)	HS-0209	2A0415G02	1	1	1	1	1				
25	Evaporator Plate		103444G01	6	6	6	6	6				
26	Separator Hook		324152-01	8	8	8	8	8				
27	Thermostatic Expansion Valve		4A1482-01	2	2	2	2	2				
28	Thermostatic Expansion Valve Cover		3A0944-01	2	2	2	2	2				
29	Thermostatic Expansion Valve Bulb Holder		3A0107-01	2	2	2	2	2				
30	Hot Gas Valve Body		4A3978-01	1	1	1	1	1				
31	Liquid Line Valve Body		4A3276-01	1	1	1	1	1				
32	Valve Coil		4A3277-01	2	2	2	2	2				
33	Check Valve		4A1373-01	2	2	2	2	2				

Title: A. Ice Cuber Assembly & Refrigeration Circuit Model: KM-1301SAH/3												
Index No.	Description	Material or Model Number	Part Number	Required Number								
				T-0 U-0	U-1 V-0	V-1 to A-0	A-1 to D-0	D-1				
34	Strainer		441569-02	1	1	1	1	1				
35	High-Pressure Switch		433441-07	1	1	-						
			463180-04			1	1	1				
36	Thermistor	L=1050 mm	429006-03	1	1	1	1	1				
37	Thermistor Holder		427430-01	1	1	1	1	1				
38	Fan Motor		4A3158-01	1	1	1	1	1				
38a	Self-Locking Nut		7N2110832	4	4	4	4	4				
39	Fan Motor Capacitor	5.0MFD, 250VAC	443192-02	1	1	1	1	1				
40	Fan Blade		4A0197-01	1	1	1	1	1				
41	Drier		4A2666-01	1	1	1	1	1				

A. Main Assembly & Refrigeration Circuit

KM-1301SWH/3

T-0 to D-1

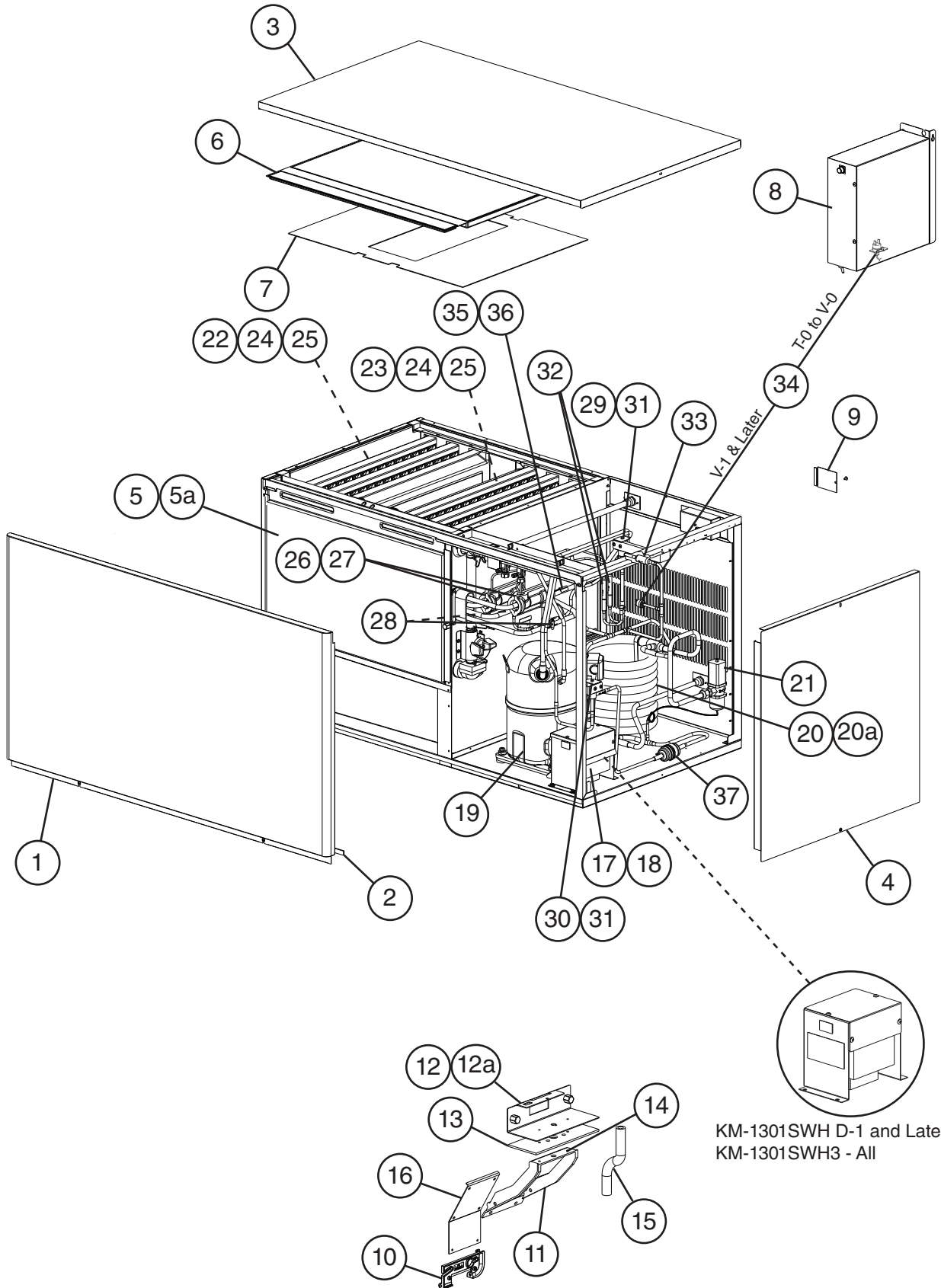

KM-1301SWH D-1 and Later
KM-1301SWH3 - All

Title: A. Main Assembly & Refrigeration Circuit Model: KM-1301SWH/3												
Index No.	Description	Material or Model Number	Part Number	Required Number								
				T-0 U-0	U-1 V-0	V-1 to A-0	A-1 B-0	C-0 C-1	D-1			
Main Assembly												
1	Front Panel		2A2224-01	1	1	1	1	1	1			
2	Gasket	L=1219 mm	4A0808L02	1	1	1	1	1	1			
3	Top Panel		2A2255-01	1	1	1	1	1	1			
4	Right Side Panel		2A2226G01	1	1	1	1	1	1			
5	Front Insulation		324215G01	1	1	1	1	1	1			
5a	Thumbscrew		415949G12	1	1	1	1	1	1			
6	Top Insulation		324216G01	1	1	1	1	1	1			
7	Spacer		324321-01	1	1	1	1	1	1			
8	Control Box Cover		3A2386-01	1	1	1	1	1	1			
9	Junction Box Cover		433410-01	1	1	1	1	1	1			
10	Bin Control Bulb Holder		3A3903-01	1	1	1	1	1	1			
11	Bin Control Bulb Holder C		216340G01	1	1	1	1	1	1			
12	Bin Control Bulb Holder D		328742-01	1	1	1	1	1	1			
12a	Thumbscrew		415949G12	2	2	2	2	2	2			
13	Spacer		439727-01	1	1	1	1	1	1			
14	Capillary Ring		425307-01	1	1	1	1	1	1			
15	Silicone Hose	L=285 mm	7730I3812	1	1	1	1	1	1			
16	Bin Control Extension Bracket		3A0408-01	1	1	1	1	1	1			
17	Main Transformer	KM-1301SWH	4A5695-01							1		
		KM-1301SWH3		1	1	1	1	1	1			
18	Voltage Tap Switch	KM-1301SWH	4A1477-01							1		
		KM-1301SWH3		1	1	1	1	1	1			
Refrigeration Circuit												
19	Compressor	KM-1301SWH	4A4134-01	1	1	1	-					
			4A4134-03				1	1	1			
		KM-1301SWH3	4A4135-01	1	1	1	-					
			4A4135-03				1	1	1			
20	Condenser	HS-0163	2A2359G04	1	1	1	1	-				
		HS-5100	3A7236-01					1	1			
20a	Hex Head Bolt w/Washer (LF)	5x12	7B0130512	2	2	2	2	2	2			
21	Water Regulating Valve		4A0911-07	1	1	1	1	1	1			
22	Left Evaporator Bank (includes 3 of item 24)	HS-0208	2A0414G02	1	1	1	1	1	1			
23	Right Evaporator Bank (includes 3 of item 24)	HS-0209	2A0415G02	1	1	1	1	1	1			
24	Evaporator Plate		103444G01	6	6	6	6	6	6			
25	Separator Hook		324152-01	8	8	8	8	8	8			
26	Thermostatic Expansion Valve		4A1482-01	2	2	2	2	2	2			
27	Thermostatic Expansion Valve Cover		3A0944-01	2	2	2	2	2	2			
28	Thermostatic Expansion Valve Bulb Holder		3A0107-01	2	2	2	2	2	2			
29	Hot Gas Valve		4A3978-01	1	1	1	1	1	1			
30	Liquid Line Valve		4A3276-01	1	1	1	1	1	1			
31	Valve Coil		4A3277-01	2	2	2	2	2	2			
32	Check Valve		4A1373-01	2	2	2	2	2	2			

Title: A. Main Assembly & Refrigeration Circuit Model: KM-1301SWH/3												
Index No.	Description	Material or Model Number	Part Number	Required Number								
				T-0 U-0	U-1 V-0	V-1 to A-0	A-1 B-0	C-0 C-1	D-1			
33	Strainer		441569-02	1	1	1	1	1	1			
34	High-Pressure Switch		433441-05	1	1	-						
			463180-05			1	1	1	1			
35	Thermistor	L=1050 mm	429006-03	1	1	1	1	1	1			
36	Thermistor Holder		427430-01	1	1	1	1	1	1			
37	Drier		4A2666-01	1	1	1	1	1	1			

A. Ice Cuber Assembly & Refrigeration Circuit

KM-1301SRH/3

T-0 to D-1

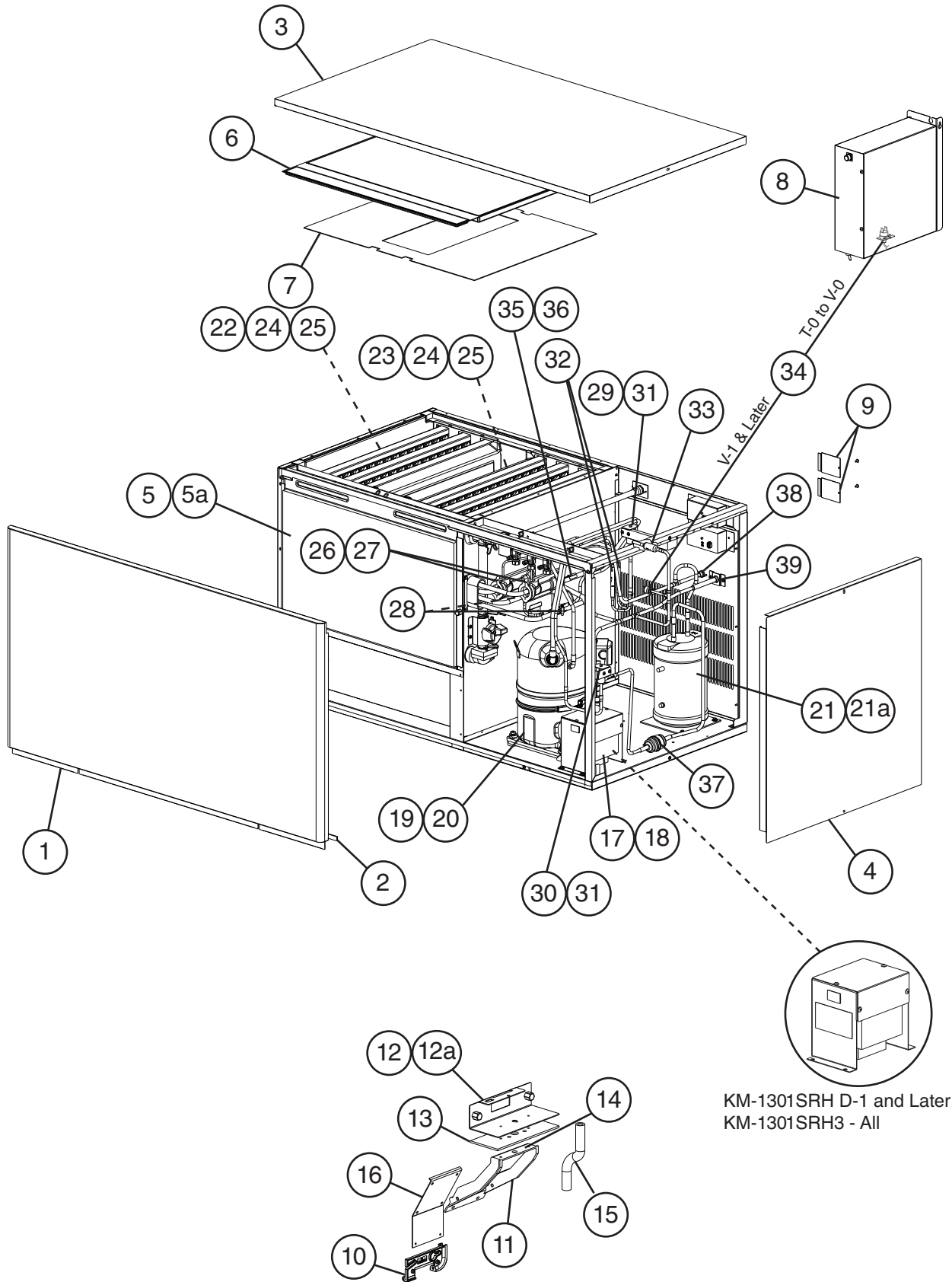

Title: A. Main Assembly & Refrigeration Circuit Model: KM-1301SRH/3													
Index No.	Description	Material or Model Number	Part Number	Required Number									
				T-0 U-0	U-1 V-0	V-1 to A-0	A-1 to D-0	D-1					
Main Assembly													
1	Front Panel		2A2224-01	1	1	1	1	1					
2	Gasket	L=1219 mm	4A0808L02	1	1	1	1	1					
3	Top Panel		2A2255-01	1	1	1	1	1					
4	Right Side Panel		2A2226G01	1	1	1	1	1					
5	Front Insulation		324215G01	1	1	1	1	1					
5a	Thumbscrew		415949G12	1	1	1	1	1					
6	Top Insulation		324216G01	1	1	1	1	1					
7	Spacer		324321-01	1	1	1	1	1					
8	Control Box Cover		3A2386-01	1	1	1	1	1					
9	Junction Box Cover		433410-01	2	2	2	2	2					
10	Bin Control Bulb Holder		3A3903-01	1	1	1	1	1					
11	Bin Control Bulb Holder C		216340G01	1	1	1	1	1					
12	Bin Control Bulb Holder D		328742-01	1	1	1	1	1					
12a	Thumbscrew		415949G12	2	2	2	2	2					
13	Spacer		439727-01	1	1	1	1	1					
14	Capillary Ring		425307-01	1	1	1	1	1					
15	Silicone Hose	L=285 mm	773013812	1	1	1	1	1					
16	Bin Control Extension Bracket		3A0408-01	1	1	1	1	1					
17	Main Transformer	KM-1301SRH	4A5695-01					1					
		KM-1301SRH3		1	1	1	1	1					
18	Voltage Tap Switch	KM-1301SRH	4A1477-01					1					
		KM-1301SRH3		1	1	1	1	1					
Refrigeration Circuit													
19	Compressor (A-1 and later utilize external crankcase heater - item 20)	KM-1301SRH	4A4134-02	1	1	1	-						
			4A4134-03				1	1					
		KM-1301SRH3	4A4135-02	1	1	1	-						
			4A4135-03				1	1					
19a	Spacer		434921-01	4	4	4	4	4					
19b	Grommet		434922-01	4	4	4	4	4					
19c	Bolt	8x45	437889-01	4	4	4	4	4					
20	Crankcase Heater		4A5397-02				1	1					
21	Receiver		437652-01	1	1	1	1	1					
21a	Hex Head Bolt w/Washer (LF)	5x10, SS	7B0230510	3	3	3	3	3					
22	Left Evaporator Bank (includes 3 of item 24)	HS-0208	2A0414G02	1	1	1	1	1					
23	Right Evaporator Bank (includes 3 of item 24)	HS-0209	2A0415G02	1	1	1	1	1					
24	Evaporator Plate		103444G01	6	6	6	6	6					
25	Separator Hook		324152-01	8	8	8	8	8					
26	Thermostatic Expansion Valve		4A1482-01	2	2	2	2	2					
27	Thermostatic Expansion Valve Cover		3A0944-01	2	2	2	2	2					
28	Thermostatic Expansion Valve Bulb Holder		3A0107-01	2	2	2	2	2					
29	Hot Gas Valve		4A3978-01	1	1	1	1	1					
30	Liquid Line Valve		4A3276-01	1	1	1	1	1					

Title: A. Main Assembly & Refrigeration Circuit Model: KM-1301SRH/3												
Index No.	Description	Material or Model Number	Part Number	Required Number								
				T-0 U-0	U-1 V-0	V-1 to A-0	A-1 to D-0	D-1				
31	Valve Coil		4A3277-01	2	2	2	2	2				
32	Check Valve		4A1373-01	2	2	2	2	2				
33	Strainer		441569-02	1	1	1	1	1				
34	High-Pressure Switch		433441-07	1	1	-						
			463180-04			1	1	1				
35	Thermistor	L=1050 mm	429006-03	1	1	1	1	1				
36	Thermistor Holder		427430-01	1	1	1	1	1				
37	Drier		4A2666-01	1	1	1	1	1				
38	Liquid Line Coupling		433751G01	1	1	1	1	1				
39	Discharge Line Coupling	KM-1301SRH	434136G01	1	1	1	1	1				
		KM-1301SRH3	434136G04	1	1	1	1	1				

Title: B. Water Circuit Model: KM-1301SAH/3, KM-1301SWH/3, KM-1301SRH/3											
Index No.	Description	Material or Model Number	Part Number	Required Number							
				T-0 to A-0	A-1 B-0	C-0 to D-1					
40	Joint Hose		439296-01	1	1	1					
41	Bypass Hose		439237-02	1	1	1					
42	Ball Valve Assembly (includes items 43 through 45)	S-0761	442137A01	1	1	1					
43	Male Adaptor		325826-01	2	2	2					
44	O-Ring		7611-P018	2	-	Replaced with thread sealant tape.					
45	Ball Valve		439293-01	1	1	1					
46	Microswitch		4A2546-01	1	1	1					
47	Joint Hose		439309-02	1	1	1					
48	Handle		215383-01	1	1	1					
49	Silicone Hose	L=390 mm	773013896	1	1	1					
50	Silicone Hose	L=140 mm	773013812	1	1	1					
51	Vinyl Hose	L=170 mm	7716-2732	1	1	1					
52	Vinyl Hose	L=230 mm	7716-2732	1	1	1					
Hose Clamps											
	Hose Clamp	25 mm	427443-03	11	11	11					
	Hose Clamp	17 mm	427443-04	1	1	1					
	Hose Clamp	14 mm	427443-07	6	6	6					
	Hose Clamp	32 mm	427443-09	4	4	4					

C. Control Box Assembly

KM-1301SAH/3, KM-1301SWH/3, KM-1301SRH/3

T-0 to D-1

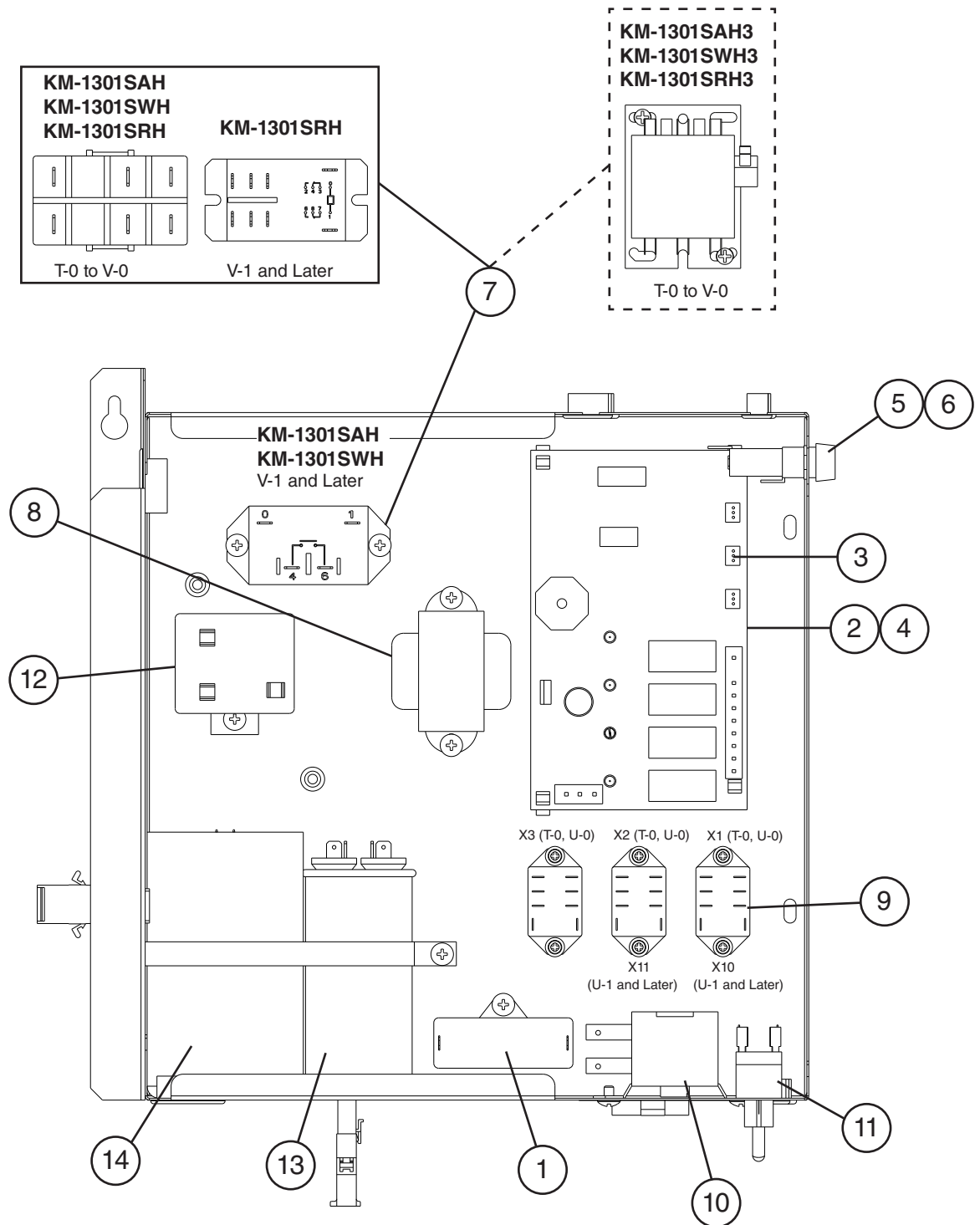

X1 (T-0, U-0) or X10 (U-1 and later) - Pump Direction Relay
 X2 (T-0, U-0) or X11 (U-1 and later) - Control Relay for X1 (T-0, U-0) or X10 (U-1 and later) Pump Direction Relay
 X3 - Harvest Pump Timer Relay (Auxiliary Code T-0, U-0)

Title: C. Control Box Assembly Model: KM-1301SAH/3, KM-1301SWH/3, KM-1301SRH/3											
Index No.	Description	Material or Model Number	Part Number	Required Number							
				T-0 U-0	U-1 V-0	V-1 to D-1					
1	Pump Motor Capacitor	10MFD, 250VAC	443192-01	1	1	1					
2	"G" Control Board		2A3792-01	1	1	1					
3	K4 Jumper		4A4883G01	1	1	1					
4	Control Board Support		4A0336-03	4	4	4					
5	Fuse	AGC-10A, 250VAC	4A0893-07	2	2	2					
6	Fuse Holder		4A5443-01	1	1	1					
7	Magnetic Contactor	KM-1301SAH	428393-01	1	1	-					
	Compressor Relay	KM-1301SWH	4A3140-01			1					
	Magnetic Contactor	KM-1301SRH	428393-01	1	1	-					
	Compressor Relay		4A5096-01			1					
	Magnetic Contactor	KM-1301SAH3 KM1301SWH3 KM-1301SRH3	4A0794-02	1	1	1					
			4A0794-01	1	1	1					
8	Control Transformer		3A0172-01	1	1	1					
9	Harvest Pump Timer Relays (X1, X2, and X3 - T-0 and U-0) (X10 and X11 - U-1 and later)		406132-07	3	2	2					
10	Bin Control Thermostat		4A2879-02	1	1	1					
11	Control Switch		443119-01	1	1	1					
12	Start Relay	KM-1301SAH	4A1107-09	1	1	1					
		KM-1301SWH KM-1301SRH	4A1107-13	1	1	1					
13	Run Capacitor	KM-1301SAH 35MFD, 370VAC	3A2005-05	1	1	1					
		KM-1301SWH KM-1301SRH 30MFD, 370VAC	3A2005-03	1	1	1					
14	Start Capacitor	KM-1301SAH 145-174MFD, 250VAC	3A0076-01	1	1	1					
		KM-1301SWH KM-1301SRH 145-174MFD, 220VAC	3A0076-11	1	1	1					

Note: Fan Capacitor for KM-1301SAH – See the Refrigeration Circuit in this manual.

D. Accessories & Labels

KM-1301SAH/3, KM-1301SWH/3, KM-1301SRH/3

T-0 to D-1

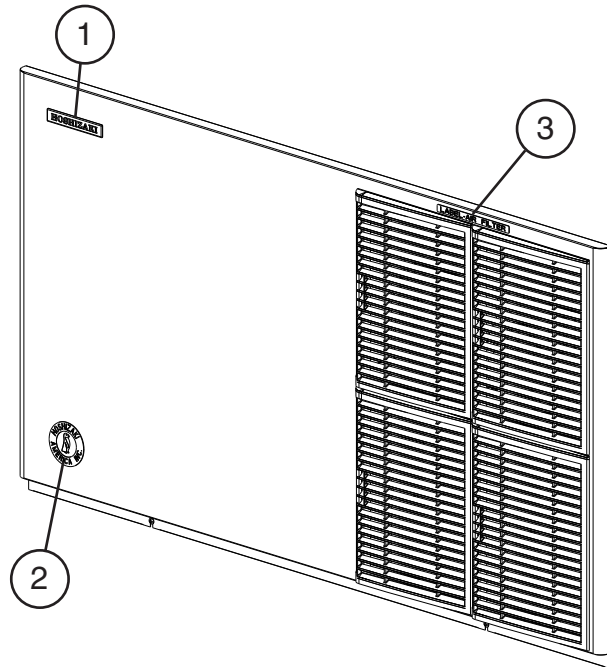

Title: D. Accessories & Labels Model: KM-1301SAH/3, KM-1301SWH/3, KM-1301SRH/3					Required Number								
Index No.	Description	Material or Model Number	Part Number	T-0 to D-1									
1	Hoshizaki Emblem Label		4A0560-01	1									
2	Penguin Label		4A0526-01	1									
3	Air Filter Label	KM-1301SAH/3	426177-01	1									
4	Universal Brace		4A0363-01	2									
4a	Hex Bolt	5x12, SS	7B02-0512	4									