



**HOSHIZAKI**

## > **IM-45CA**

daily ice production capacity of up to 47kg



Cube ice is perfectly symmetrical and leaves a good impression with its hard, crystal clear quality that melts very slowly; allowing customers to enjoy their favourite drink longer. The I-Fit series of cube ice maker produces standard size ice (28x28x32mm) that is applicable in many settings and designed for uncomplicated usage from start to finish.



> **IM-45CA**

CUBE ICE MAKER SERIES

**I-FIT**  
SERIES

### **FEATURES**

- > flush-back design for easy installation
- > round front door for quick access to ice
- > one-piece door design and pull-out air filter for simple cleaning
- > front water valve access for easy serviceability
- > sharp stainless steel exterior



### **UNIQUE ICE PRODUCTION SYSTEM**

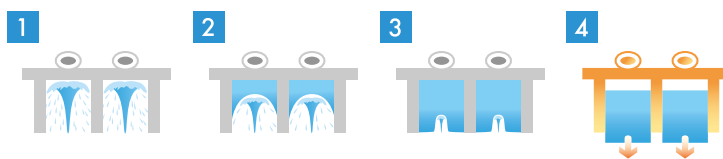

### **ICE SIZE**

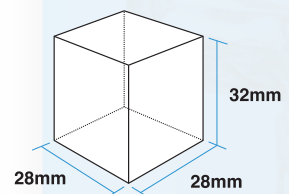

# DIMENSIONS & SPECIFICATION

**CUBE ICE MAKER AIR SYSTEM TOP VIEW**

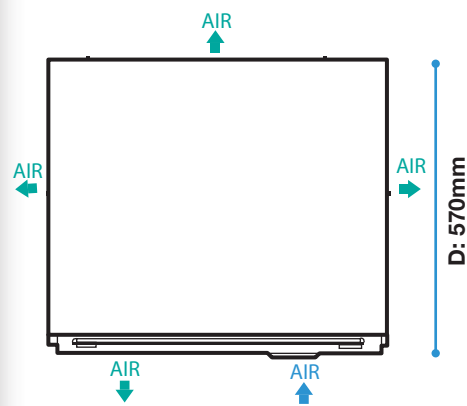

**FRONT VIEW**

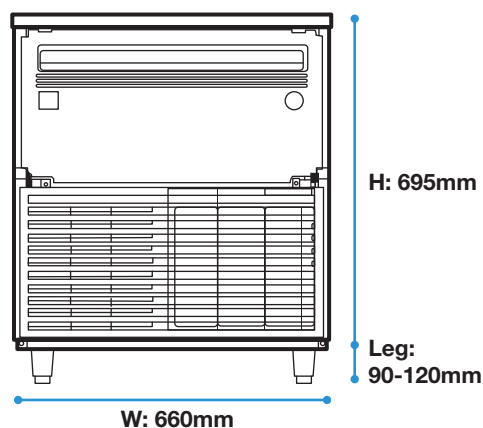

**BACK VIEW**

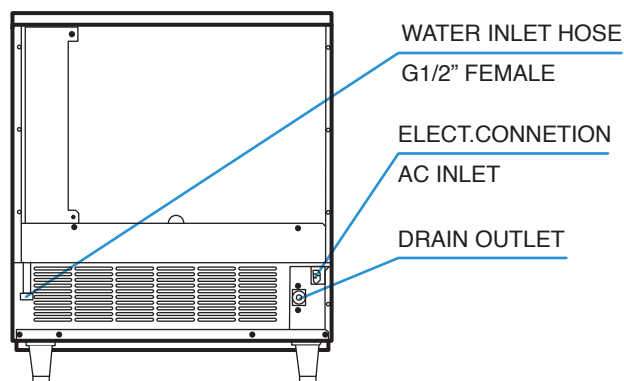

<b>MODEL NAME</b>	<b>IM-45CA</b>	
<b>ICE DIMENSIONS (MM) (W x D x H)</b>	28 x 28 x 32	
<b>DIMENSIONS (MM) (W x D x H)</b>	Body : 660 x 570 x 695 / Leg Height : 90-120 mm	
<b>PACKED DIMENSIONS (MM) (W x D x H)</b>	760 x 680 x 880	
<b>WEIGHT (NETT/GROSS)</b>	52 KG / 65 KG	
<b>AMPERAGE / STARTING AMPERAGE</b>	2.0A / 16A	
<b>ELECTRICAL CONSUMPTION</b>	310 W	
<b>REFRIGERANT CHARGE</b>	R134a	
<b>HEAT REJECTION (AT32°C/WT21°C)</b>	670 W (576 kcal/h)	
<b>ICE PRODUCTION PER 24H (15MM)</b>	(AT10°C/WT10°C)	47 KG
	(AT21°C/WT15°C)	44 KG
	(AT32°C/WT21°C)	38 KG
<b>WATER CONSUMPTION PER 24H (AT21°C/WT15°C)</b>	0.12 m <sup>3</sup>	
	2.7L / 1KG ICE	
<b>ICE PRODUCTION (AT21°C/WT15°C)</b>	<b>FREEZE CYCLE TIME</b>	23 MIN
	<b>PER CYCLE</b>	0.67 KG / 30 PCS
<b>STORAGE CAPACITY</b>	15 KG	

**• WARRANTY:**

Two years parts & labour for entire unit, 3<sup>rd</sup> year on compressor only. Excluding door & exterior damages

**OPERATING CONDITIONS:** • Voltage Range: ±6% • Ambient Temperature: 1°-40°C

• Water Supply: 5°-35°C / 0.07-0.8 Mpa / 7.25-116 PSI • AC Supply Voltage: 1/220-240V / 50 Hz