



MODULAR CUBER

**IM-220AWA
IM-220AWA-23
IM-220AWA-21**

PARTS LIST

[CHINA, TAIWAN]

M028-C201
M028-C251
M028-C204
M028-C205

F-1 JUN. 2016
F-2 AUG. 2016

List of Specifications

IM-220AWA	M028-C201	For CHINA
IM-220AWA	M028-C251	For TAIWAN 230V 60Hz
IM-220AWA-23	M028-C204	For CHINA
IM-220AWA-21	M028-C205	For CHINA 21mm ice cube

AUXILIARY CODE

U - 1

The auxiliary code is the first two characters in the serial number. The first character indicates the production year. Years progress or regress in alphabetical order. The series of letters and skipped letters depend on UL listing, production, and model. See the auxiliary code(s) and corresponding year(s) on the front cover.

The second character indicates significant part changes within the same year. Base is "1" and this number advances for each change. If there is no significant part change at the turn of the year, this number starts from "0."

FASTENER PART NUMBER

SCREWS

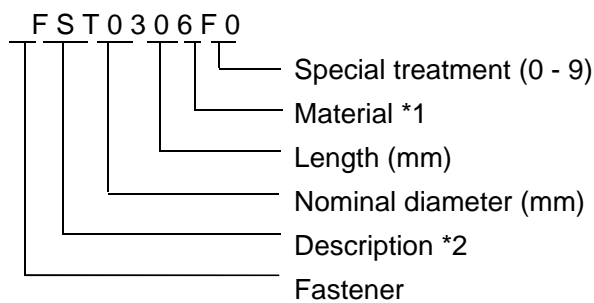

*1 Material

F: Steel
S: Austenitic stainless steel
M: Martensitic stainless steel
B: Copper alloy
P: Polycarbonate
N: Polyamide
V: PVC
A: ABS
X: Polyacetal
L: Aluminum

NUTS & WASHERS

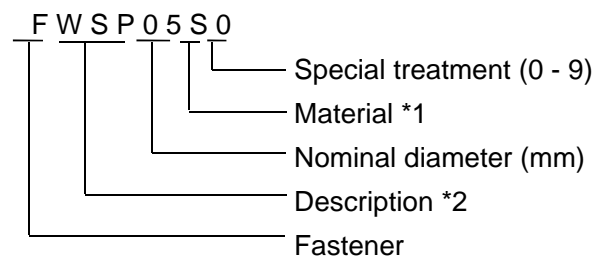

*2 Description

First letter
S: Machine screw
T: Tapping screw
M: Wood screw
B: Bolt
W: Washer
N: Nut

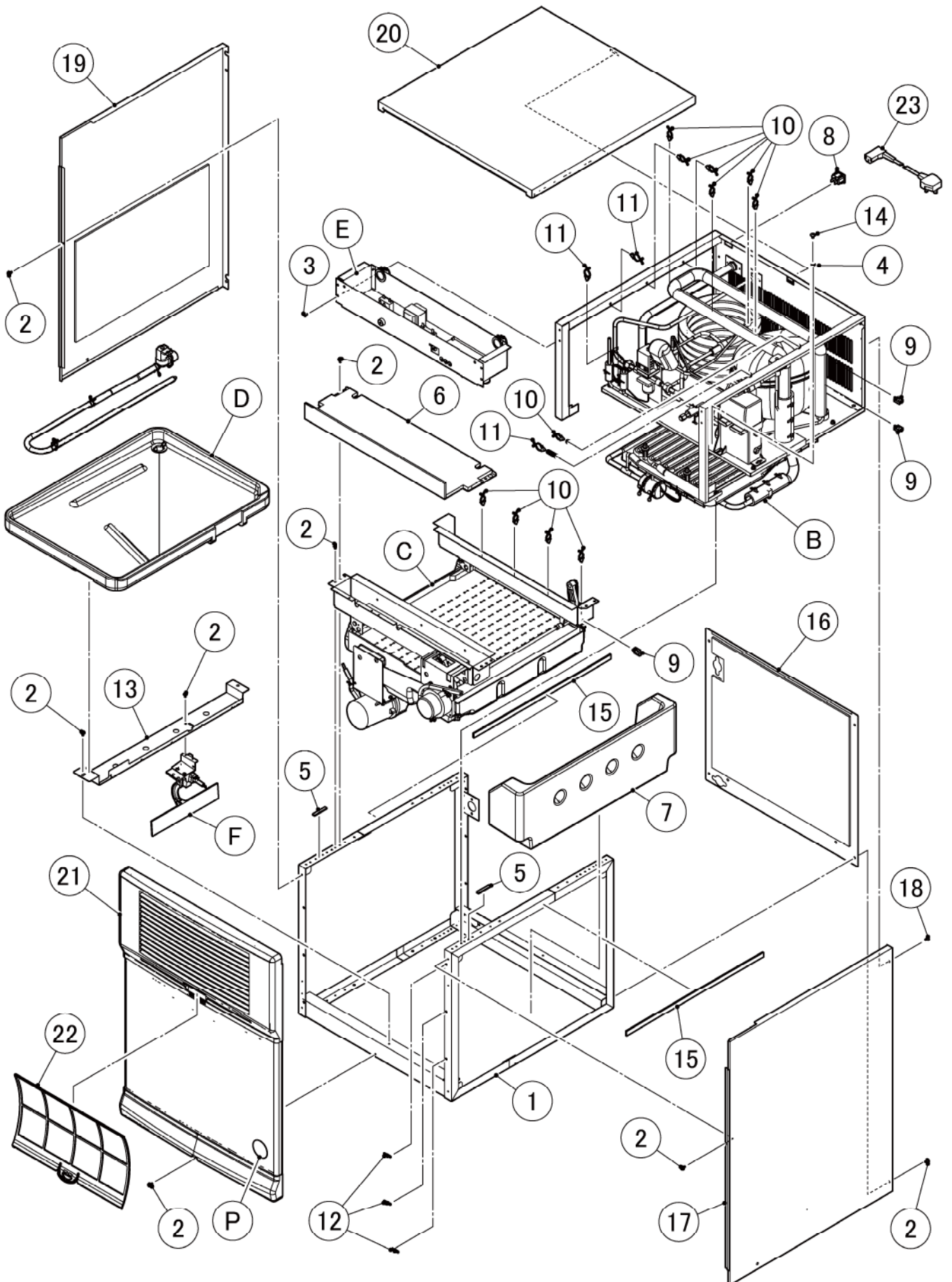

MODEL: **IM-220AWA**

TITLE: **A. ICE CUBER ASSY**

INDEX NO.	DESCRIPTION	MATERIAL OR MODEL NUMBER	PART NUMBER	REQ'D NUMBER				
				F-1	F-2			
B	REFRIGERATION CIRCUIT		124534A01	1	1			
		220AWA-23	1H6163A01	-	1			
		220AWA-21	1H6171A01	-	1			
C	MECHANISM ASSY		121972A01	1	-			
			121972A02	-	1			
D	WATER CIRCUIT ASSY		262379A01	1	1			
E	CONTROL BOX ASSY		263817A01	1	1			
F	BIN SWITCH-2 ASSY		477489A01	1	1			
P	LABEL LOCATION		262806004	1	1			
Q	ACCESSORIES		A02540002	1	1			
1	FRAME		377007G01	1	1			
2	FLANGE BOLT (C-TITE)		FTR0408M0	22	22			
3	T2 TRUSS HEAD SCREW		FT20408F0	4	4			
4	SPRING WASHER		FWSP05S0	1	-			
			FWSP04S0	-	1			
5	INSULATION (B) - FRAME		477491Z01	2	2			
6	COVER		476755G01	1	1			
7	CHUTE		121939P01	1	1			
8	CONNECTOR		P02656-01	1	1			
9	WIRE SADDLE		428060-03	3	3			
10	WIRE RETAINER	No.249	427902-03	10	10			
11	WIRE RETAINER	No.4253	427902-05	3	3			
12	NYLON TIE	CV-70	7920-0001	3	3			
13	FRAME - BIN SWITCH		262285M01	1	1			
14	TRUSS HEAD MACHINE SCREW		FST0408S0	1	1			
15	INSULATION - FRAME		477255Z01	2	2			
16	REAR PANEL		376519G01	1	1			
17	SIDE PANEL (R)		377631G01	1	1			
18	T2 TRUSS HEAD SCREW		FT20408S0	2	2			
19	SIDE PANEL (L)		377632G01	1	1			
20	TOP PANEL		262283M01	1	1			
21	FRONT PANEL ASSY		376560G01	1	1			

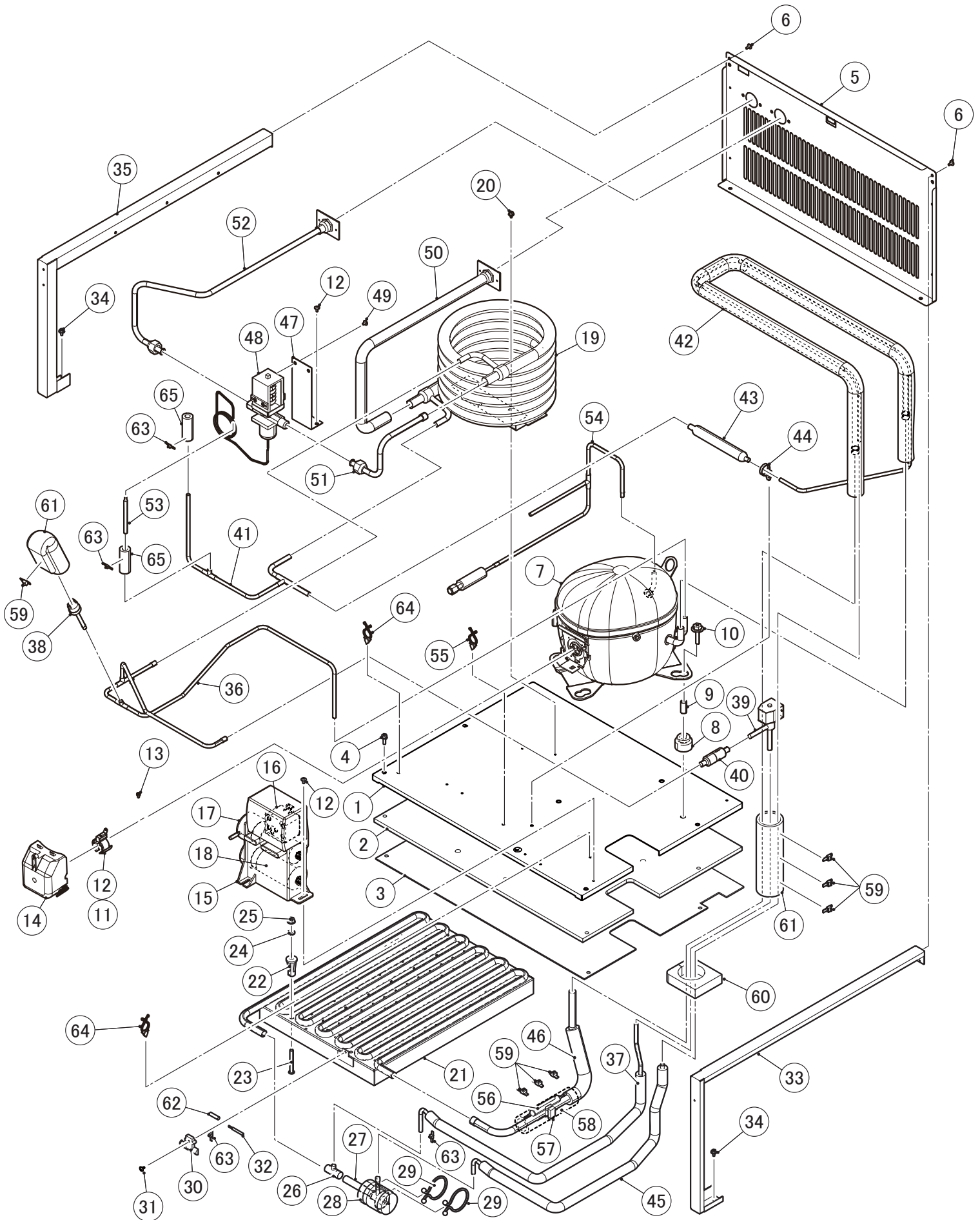

MODEL: **IM-220AWA**

TITLE: **B. REFRIGERATION ASSY**

INDEX NO.	DESCRIPTION	MATERIAL OR MODEL NUMBER	PART NUMBER	REQ'D NUMBER				
				F-1	F-2			
1	BASE		383751G01	1	1			
2	INSULATION - BASE		383752P01	1	1			
3	COVER - BASE		376510P01	1	1			
4	HEX HEAD BOLT		FBK0520S0	4	4			
5	REAR PANEL		270068M01	1	1			
6	T2 TRUSS HEAD SCREW		FT20408F0	8	8			
7	COMPRESSOR		P02104-01	1	1			
8	GROMMET		P00846-01	4	4			
9	SPACER		P00847-01	4	4			
10	BOLT		436206-03	4	4			
11	PROTECTOR		P02105-01	1	1			
12	PROTECTOR RETAINER		P00839-01	1	1			
13	SCREW		P00840-01	1	1			
14	TERMINAL COVER		P00836-01	1	1			
15	WIRE KIT		P00845-01	1	1			
16	STARTER		P00842-01	1	1			
17	RUN CAPACITOR		P02145-01	1	1			
18	START CAPACITOR		P02106-01	1	1			
19	CONDENSER - WATER COOLED		P01912-01	1	1			
20	HEX HEAD BOLT		FBK0408S0	2	2			
21	EVAPORATOR		2X2459G01	1	1			
		220AWA-23	2H1833G03	-	1			
		220AWA-21	208205G04	-	1			
22	COLLAR		3H3879-01	4	4			
23	SCREW-EVAPORATOR		4Y4922M02	4	4			
		220AWA-23 220AWA-21	4Y4922M03	-	4			
24	WASHER		4H0777-01	4	4			
25	FLANGE NUT		FNHF06S0	4	4			
26	TEE		420041-10	1	1			
27	EXPANSION VALVE	China	P04147-01	1	1			
		Taiwan	P02652-02	-	1			
		220AWA-23 220AWA-21	P01874-01	-	1			

MODEL: **IM-220AWA**

TITLE: **B. REFRIGERATION ASSY**

INDEX NO.	DESCRIPTION	MATERIAL OR MODEL NUMBER	PART NUMBER	REQ'D NUMBER				
				F-1	F-2			
28	VALVE COVER		3Y3196P01	1	1			
		220AWA-23 220AWA-21	3Y3051P01	-	1			
29	CLAMP		P00752-01	2	2			
30	HOLDER - THERMISTOR		3H9642-01	1	1			
31	S-TITE TRUSS HEAD SCREW		FTS0408M0	1	1			
32	THERMISTOR-CUBE COTROL		P00350-01	1	1			
33	SIDE FRAME (R) - TOP SIDE		262273M01	1	1			
34	Flange Bolt (C-TITE)		FTR0408M0	4	4			
35	SIDE FRAME (L) - TOP SIDE		262274M01	1	1			
36	COPPER TUBE (A) - HIGH SIDE		270069G01	1	1			
37	COPPER TUBE - HOT GAS		270070G01	1	1			
		220AWA-23 220AWA-21	2X3771G01	-	1			
38	PRESSURE SWITCH		459863-03	1	1			
39	HOT GAS VALVE		P04242-01	1	1			
40	STRAINER		P00812-01	1	1			
41	COPPER TUBE (B) - HIGH SIDE		383755G01	1	1			
42	HEAT EXCHANGER		270072G01	1	1			
43	DRIER		P00026-01	1	1			
44	TIE		436156-02	1	1			
45	COPPER TUBE (C) - HIGH SIDE		482429G01	1	1			
		220AWA-23 220AWA-21	2X3772G01	-	1			
46	COPPER TUBE - LOW SIDE		482430G01	1	1			
		220AWA-23 220AWA-21	3Z1107G01	-	1			
47	REGULATOR BRACKET		482431M01	1	1			
48	WATER REGULATOR		P04025-01	1	1			
49	TRUSS HEAD SCREW		FST0406F0	2	2			
50	COPPER TUBE (A) - WATER CIRCUIT		482433G01	1	1			
51	COPPER TUBE (B) - WATER CIRCUIT		482434G01	1	1			
52	COPPER TUBE (C) - WATER CIRCUIT		383761G01	1	1			
53	COPPER TUBE (B) - CAPILLARY		446047-02	1	1			
54	COPPER TUBE - ACCESS		383762G01	1	1			

