

No.	L009-3691
ISSUED:	Jun. 11, 2012
REVISED:	Jan. 23, 2013



**HOSHIZAKI
CUBELET ICE DISPENSER**

MODEL DCM-120KE(-P)

(L009, L009-C101, L009-C201,
L009-C301, L010, L010-C101,
L010-C201, L010-C301)

PARTS LIST
(GENERAL)

B-1 MAY. 2012
B-2 OCT. 2012
B-3 OCT. 2012

List of Specifications

DCM-120KE	L009	CONTINENTAL	50Hz
	L009-C101	UK & MIDDLE EAST	50Hz / 60Hz
	L009-C201	OCEANIA	50Hz
	L009-C301	CHINA	50Hz
DCM-120KE-P	L010	CONTINENTAL	50Hz
	L010-C101	UK & MIDDLE EAST	50Hz / 60Hz
	L010-C201	OCEANIA	50Hz
	L010-C301	CHINA	50Hz

Auxiliary Codes

Auxiliary Code Breakdown

The auxiliary code is the first two characters in the serial number. The first character indicates the year. Years progress or regress in alphabetical order. The series runs from "A" through "V" and the letters "I" and "O" are skipped. The second character indicates significant part changes within a year. Base is "0" and this number advances for each change. In cases where there is a letter in parentheses, this designates the month. This is the last character in the serial number. The series runs from "(A)" through "(M)" and the letter "(I)" is skipped. This designation is only included when identifying a parts change within an auxiliary code.

Note About Ordering Parts

Most assemblies cannot be ordered as complete units; parts in the assemblies generally must be ordered separately.

MARKS LOCATED UNDER THE AUXILIARY CODE

- = Part deleted.
- x = Part deleted and replaced by "o" part.
- o = New part in place of "x" part.

FASTENER PART NUMBER

SCREWS

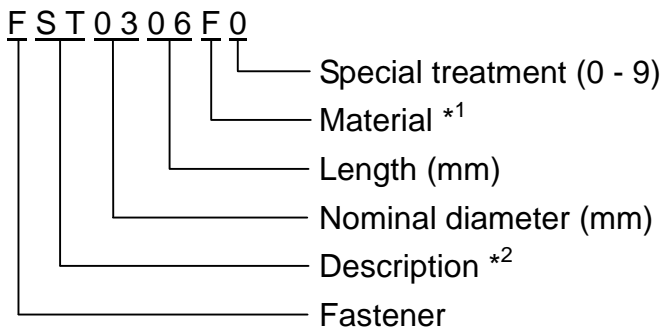

*1 Material

- F: Steel
- S: Austenitic stainless steel
- M: Martensitic stainless steel
- B: Copper alloy
- P: Polycarbonate
- N: Polyamide
- V: PVC
- A: ABS
- X: Polyacetal
- L: Aluminum

NUTS & WASHERS

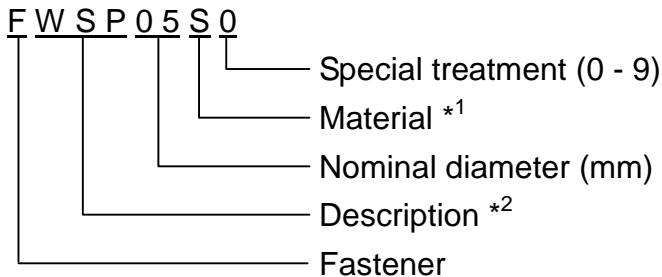

*2 Description

- First letter
- S: Machine screw
- T: Tapping screw
- M: Wood screw
- B: Bolt
- W: Washer
- N: Nut

GENERAL

MODEL: DCM-120KE(-P)		TITLE: A. ICE CUBER ASSY					
INDEX NO.	DESCRIPTION	MATERIAL OR MODEL NUMBER	PART NUMBER	REQ'D NUMBER			
				B-1	B-2	B-3	
B	BASE ASSY		376436A01	1	-		
			377814A01		1	1	
C	ICE MAKING UNIT		262210A01	1	1	1	
D	REFRIGERATION CIECUIT		121891A01	1	1	1	
E	DRAIN PANEL ASSY		374966A01	1	1	1	
F	WATER CIRCUIT		121894A01	1	1	1	
G	CONTROL BOX ASSY		262214A01	1	1	1	
		DCM-120KE-P	262214A02	1	1	1	
H	FRONT PANEL ASSY - 115LO	DCM-120KE	374967A01	1	1	1	
J	LEVER - UNIT	DCM-120KE	262217A01	1	1	1	
K	FRONT PANEL (UP)		121898A01	1	1	1	
L	FRONT COVER		374962A01	1	1	1	
M	LABEL LOCATION		122029A01	1	1	1	
		DCM-120KE-P	122029A02	1	1	1	
T	ACCESSORIES		A02554-01	1	1	1	
		CHINA	A02554001	1	1	1	
1	LEG		458051-02	4	4	4	
2	DRAIN PAN - GM		259846P01	1	1	1	
3	SEAL WASHER		458299-01	3	3	3	
4	SPRING WASHER		FWSP08S0	3	3	3	
5	SCREW - M8		458298-02	3	3	3	
6	PLATE		121893M01	1	-		
			122415M01		1	1	
7	TRUSS HEAD SCREW		FST0408F0	14	15	15	
8	FRAME (L)		262213M01	1	-		
			264002M01		1	1	
9	TRUSS HEAD TAPPING SCREW T1		FT10416F0	2	2	2	
	TRUSS HEAD TAPPING SCREW T2		FT20416F0		2	2	

GENERAL

MODEL: DCM-120KE(-P)				TITLE: A. ICE CUBER ASSY			
INDEX NO.	DESCRIPTION	MATERIAL OR MODEL NUMBER	PART NUMBER	REQ'D NUMBER			
				B-1	B-2	B-3	
10	TRUSS HEAD SCREW		FST0508F0	4	4	4	
11	TRANSEFOMER		P02552-01	1	1	1	
12	FRAME (R)		263224M01	1	-		
			264001M01		1	1	
13	CENTER FRAME		376454M01	1	-		
			377811M01		1	1	
14	TOP FRAME		376455M01	1	1	1	
15	BUSHING		420470-06	1	1	1	
16	WIRE RETAINER	No.4253	427902-05	17	17	17	
17	CLAMP	No.248	427902-04	1	1	1	
18	PAN HEAD SCREW SW		FSK0408S0	3	3	3	
19	SPOUT		259891P01	1	1	1	
20	POWER CORD	CONT Plug	P02697-01	1	1	1	
		UK & MIDDLE EAST	P02698-01	1	1	1	
		OCEANIA	P02760-01	1	1	1	
	POWER SUPPLY CORD	CHINA	P00193-01	1	1	1	
21	BUSHING		448949-01	1	1	1	
22	REAR PANEL		121899M01	1	1	1	
23	SIDE PANEL (R)		121900M01	1	1	1	
24	SIDE PANEL (L)		121901M01	1	1	1	
25	TRUSS HEAD SCREW P		FSG0408S0	21	21	21	
26	TOP PANEL - 115		121228P01	1	1	1	
27	AIR FILTER		341489G01	1	1	1	
28	BRACKET - BOTTON	DCM-120KE-P	376725M01	1	1	1	
29	FRONT PANEL (LO1) - 115	DCM-120KE-P	121230P02	1	1	1	

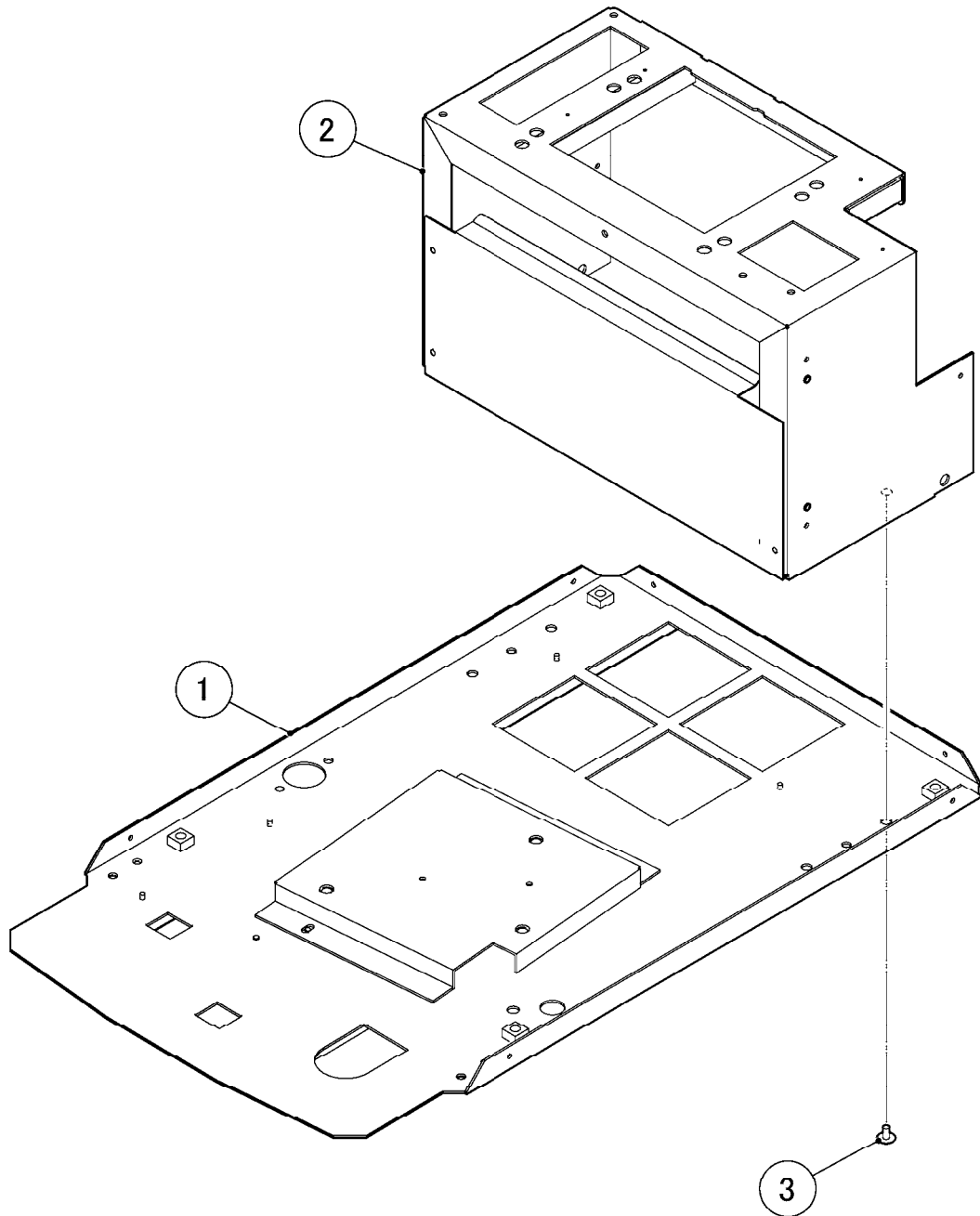

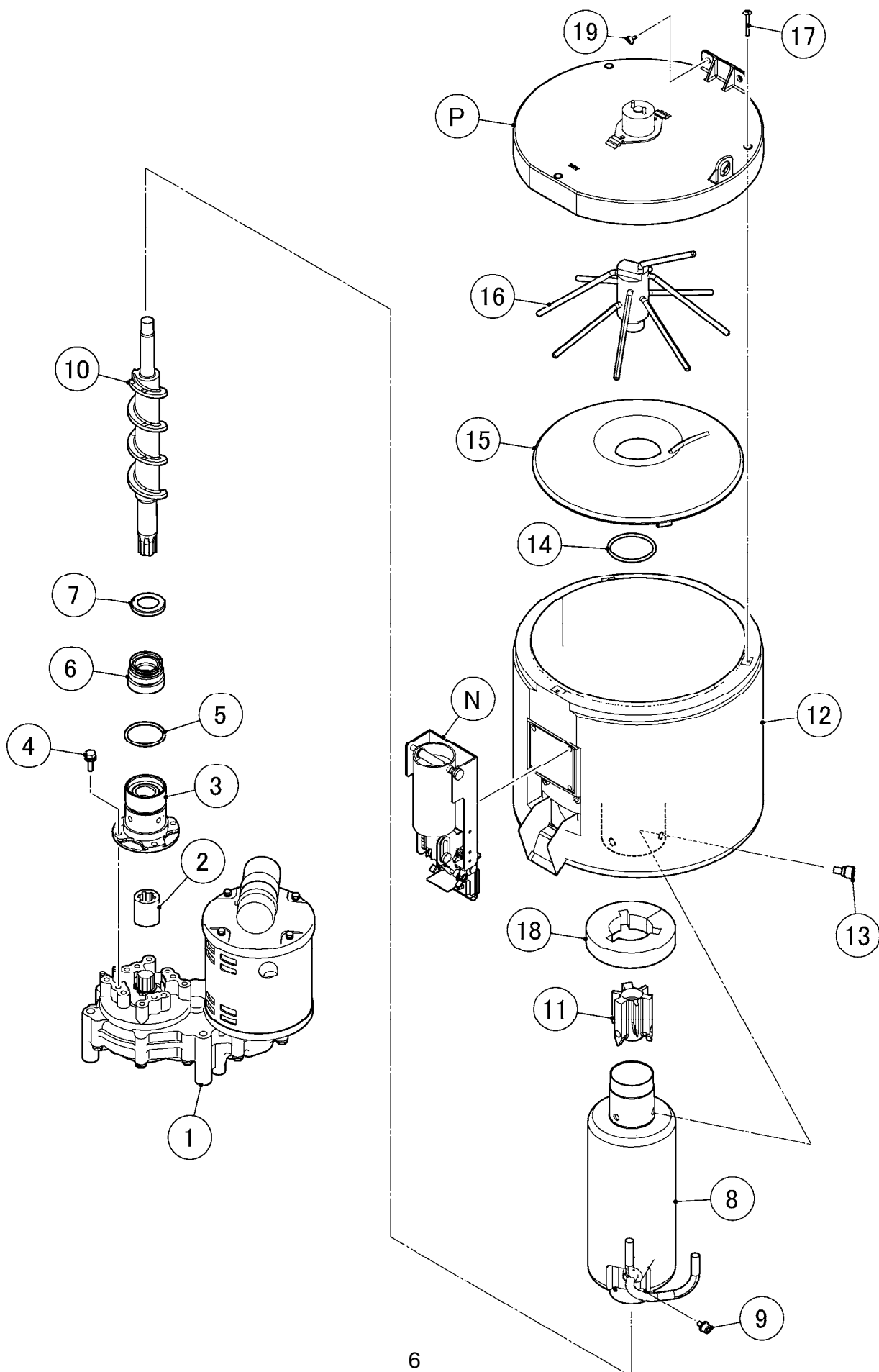

GENERAL

MODEL: DCM-120KE(-P)				TITLE: C. ICE MAKING UNIT			
INDEX NO.	DESCRIPTION	MATERIAL OR MODEL NUMBER	PART NUMBER	REQ'D NUMBER			
				B-1	B-2	B-3	
N	SHUTTER ASSY		121220A03	1	1	1	
P	COVER ASSY - BIN TOP		228513A02	1	1	1	
1	GEARMOTOR		P02068-02	1	1	1	
2	COUPLING - SPLINE		418316-01	1	1	1	
3	HOUSING		206013G05	1	1	1	
4	BOLT		458660-01	4	4	4	
5	O-RING		7616-G040	1	1	1	
6	MECHANICAL SEAL		432491-01	1	1	1	
7	RING		432494-01	1	1	1	
8	EVAPORATOR (AD)		374919G02	1	1	1	
9	SCREW		P01718-01	4	4	4	
10	AUGER		361013G01	1	1	1	
11	EXTRUDING HEAD 45C		327236002	1	1	1	
12	STORAGE BIN		122494G01	1	1	1	
13	SEAL BOLT - M8		P01768-02	3	3	3	
14	O-RING		7616-P048	1	1	1	
15	DRIP RING		207754-03	1	1	1	
16	AGITATOR		348969G01	1	1	1	
17	TRUSS HEAD SCREW		FST0430S0	3	3	3	
18	COVER - CASING		471716P01	1	1	1	
19	TRUSS HEAD SCREW		FST0408S0	2	2	2	

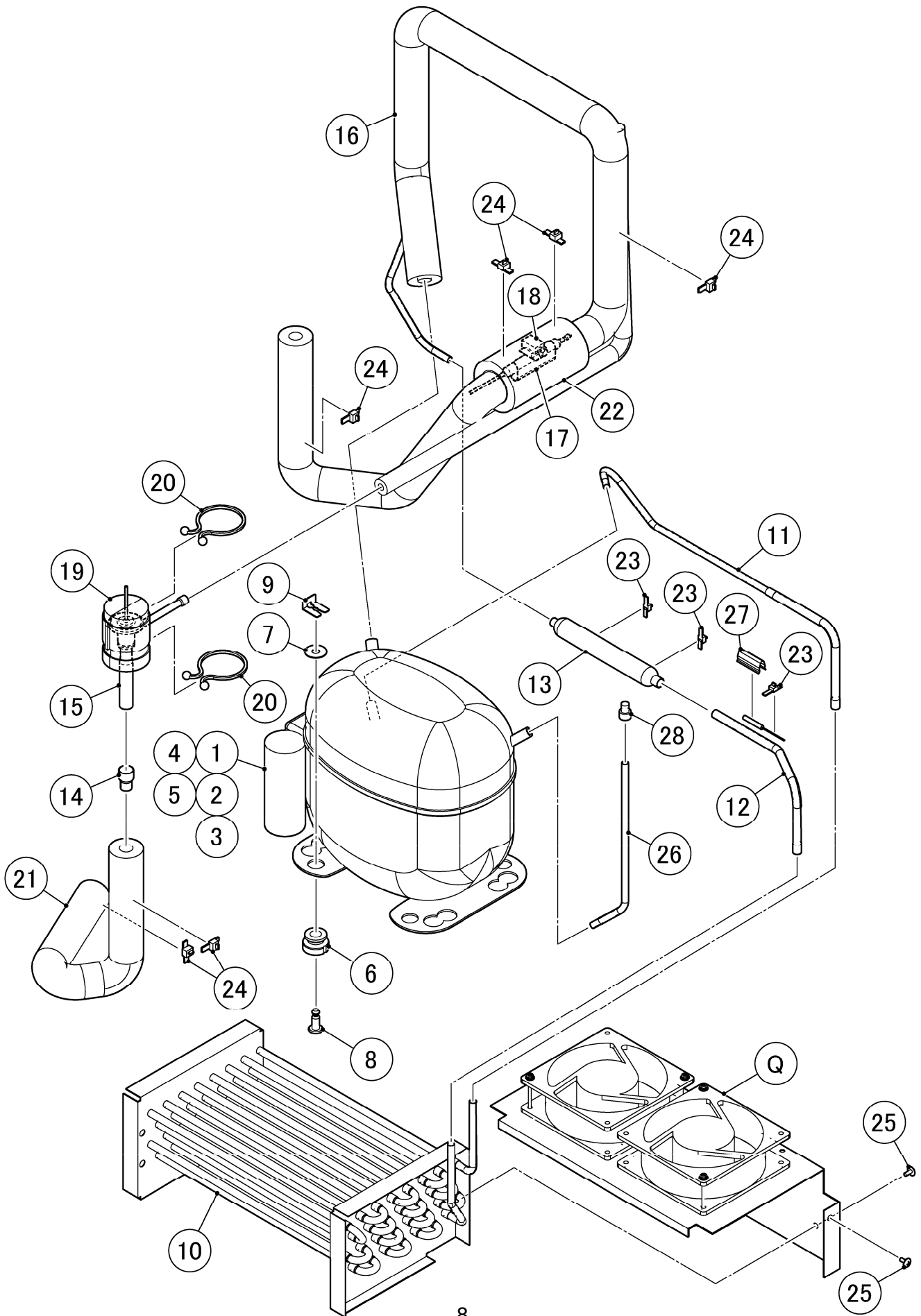

GENERAL

MODEL: DCM-120KE(-P)				TITLE: D. REFRIGERATION CIRCUIT			
INDEX NO.	DESCRIPTION	MATERIAL OR MODEL NUMBER	PART NUMBER	REQ'D NUMBER			
				B-1	B-2	B-3	
Q	FAN MOTOR ASSY		376447A01	1	1	1	
1	COMPRESSOR		453580-01	1	1	1	
2	STARTING RELAY		453581-01	1	1	1	
3	START CAPACITOR		456350-01	1	1	1	
4	COVER		459924-01	1	1	1	
5	CORD RELIEF		452239-01	1	1	1	
6	GROMMET		450897-01	4	4	4	
7	WASHER CUSHION		P02793-01	4	4	4	
8	STEEL PIN		452255-01	4	4	4	
9	CLIP		452256-01	4	4	4	
10	CONDENSER		P02163-01	1	1	1	
11	COPPER TUBE - DISCHARGE		262211G01	1	1	1	
12	COPPER TUBE - LIQUID		476729M01	1	1	1	
13	DRIER		P00026-01	1	1	1	
14	REDUCER		421904-01	1	1	1	
15	EXPANSION VALVE		446808-01	1	1	1	
16	HEAT EXCHANGER		121892G01	1	1	1	
17	HOLDER - EXPV		451267-01	1	1	1	
18	CLAMP		443461-01	1	1	1	
19	VALVE COVER		3Y3196P01	1	1	1	
20	CLAMP		P00752-01	2	2	2	
21	Insulation Tube		H71333B40	1	1	1	
22	Insulation Tube		H73555B10	1	1	1	
23	TIE	CV-150	7920-0003	3	3	3	
24	NYLON TIE	CV-250	7920-0011	6	6	6	
25	T2 TRUSS HEAD SCREW		FT20408F0	4	4	4	
26	COPPER TUBE (A) - ACCESS		476730M01	1	1	1	
27	THERMISTOR - HOLDER		458132-01	1	1	1	

GENERAL

MODEL: DCM-120KE(-P)		TITLE: D. REFRIGERATION CIRCUIT					
INDEX NO.	DESCRIPTION	MATERIAL OR MODEL NUMBER	PART NUMBER	REQ'D NUMBER			
				B-1	B-2	B-3	
28	LOCKRING STOPPER		P01677-01	1	1	1	

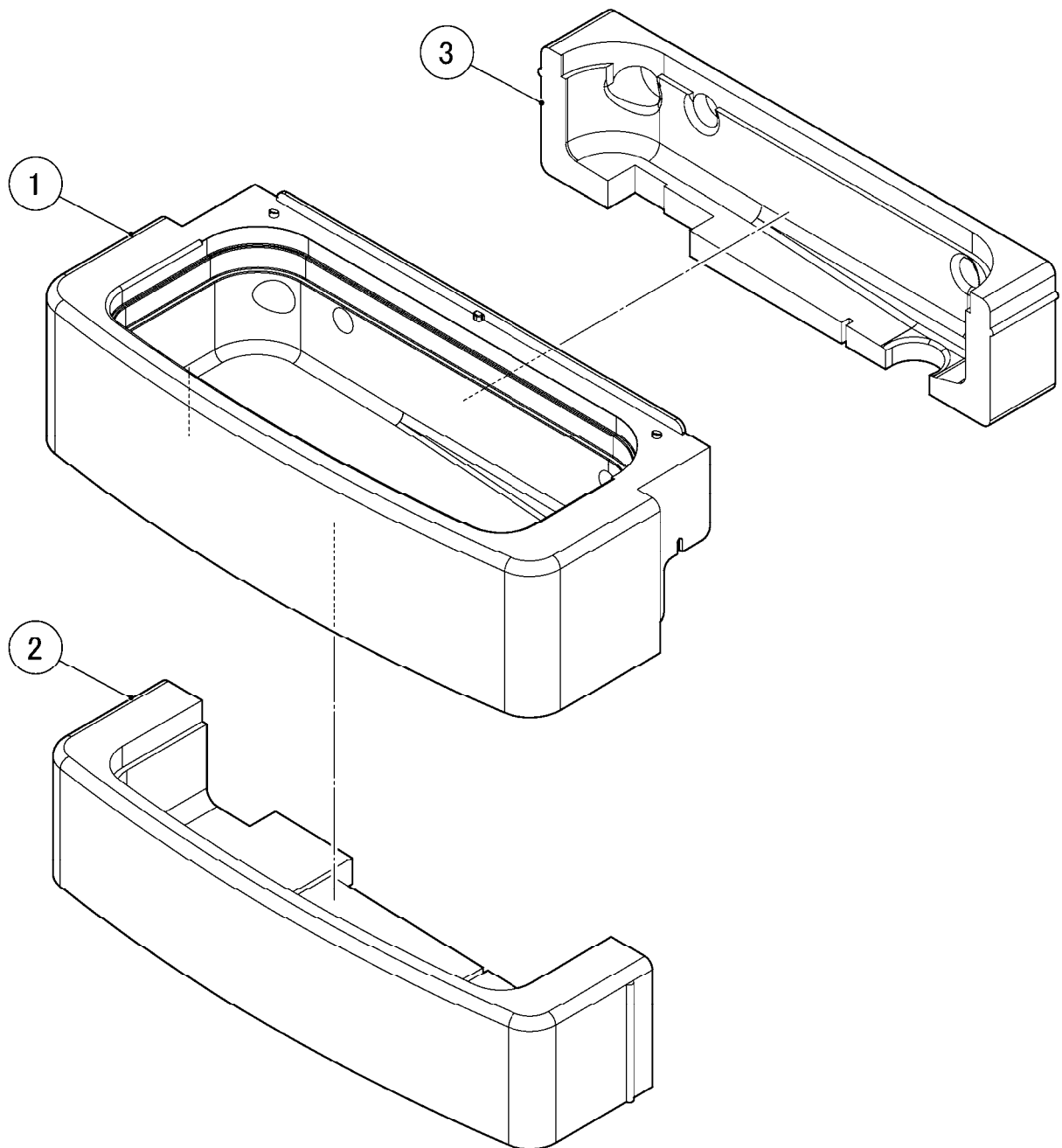

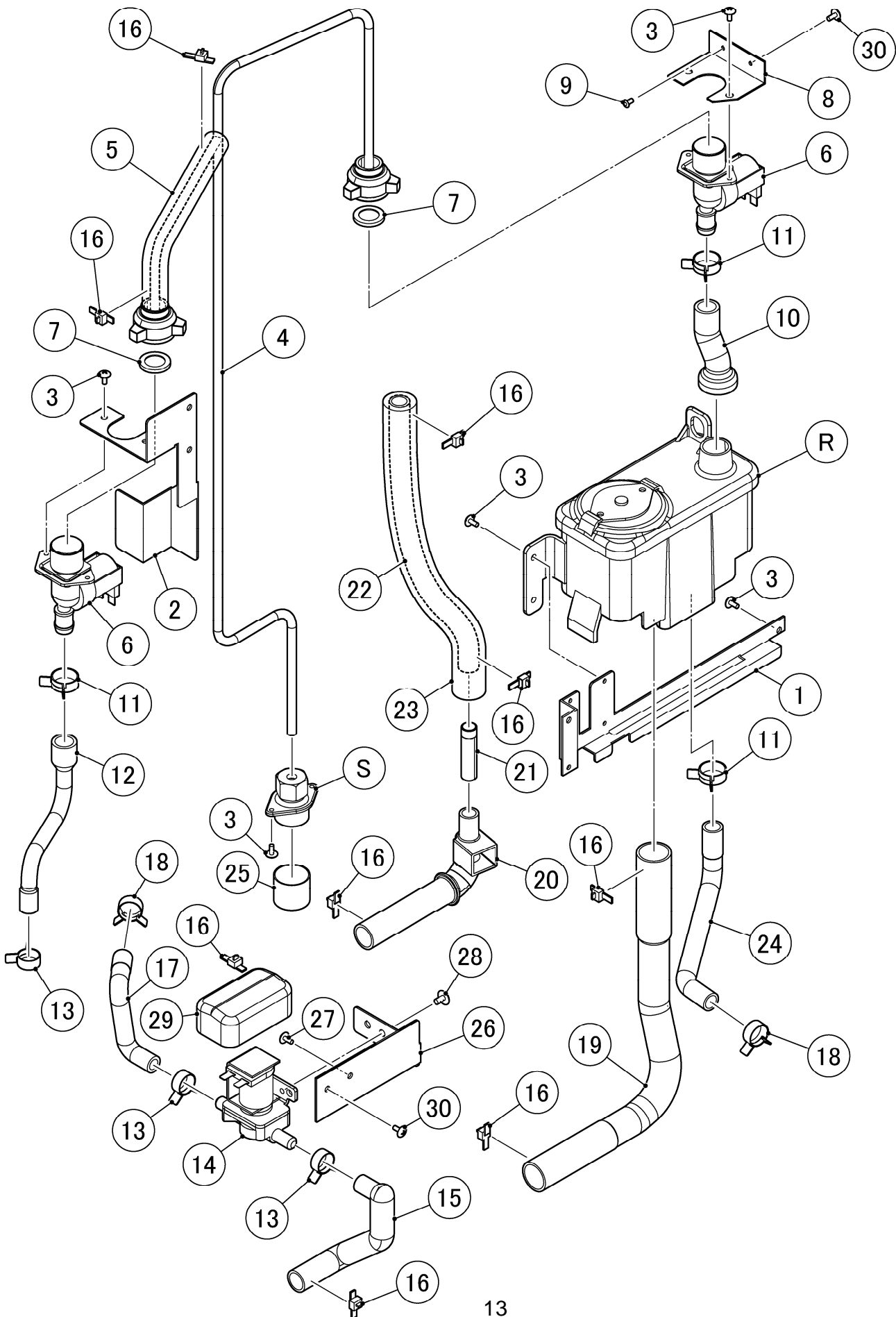

GENERAL

MODEL: DCM-120KE(-P)				TITLE: F. WATER CIRCUIT			
INDEX NO.	DESCRIPTION	MATERIAL OR MODEL NUMBER	PART NUMBER	REQ'D NUMBER			
				B-1	B-2	B-3	
R	TANK ASSY		374930A01	1	1	1	
S	FITTING - WATER SUPPLY		376409A01	1	1	1	
1	RESERVOIR BRACKET		262223M01	1	-	-	
			264207M01		1	1	
2	BRACKET(B) - WV		376449M01	1	1	1	
3	TRUSS HEAD SCREW		FST0408S0	11	-	-	
					12	12	
4	PIPE - WATER SUPPLY		376450G01	1	1	1	
5	INSULATION TUBE		H71020B20	1	1	1	
6	WATER VALVE		452993-01	2	2	2	
7	STOPPER COVER(R)		4X1497G01	2	2	2	
8	BRACKET (A) - WV		476731M01	1	-		
			478031M01		1	1	
9	RIVET	SSD42SSBS(t1.6~3.2)	7170-0002	2	-		
10	HOSE - WATER SUPPLY		374933R01	1	1	1	
11	CLIP BAND		423866-05	3	3	3	
12	HOSE (B) - WATER SUPPLY		475485R01	1	1	1	
13	CLIP BAND		423866-01	3	3	3	
14	WATER VALVE		468655-01	1	1	1	
15	HOSE - WV OUTLET		377147P01	1	1	1	
16	NYLON TIE	CV-200	7920-0010	9	9	9	
17	HOSE(115) - EVA OUTLET		377148P01	1	1	1	
18	CLAMP		423866-04	2	2	2	
19	OVERFLOW HOSE - 115		374937R01	1	1	1	
20	HOSE 120 - GM DRAIN		376451R01	1	1	1	
21	CONNECTION PIPE		475535M01	1	1	1	
22	HOSE (Q)		334235-12	1	1	1	
23	Insulation Tube		H71626300	1	1	1	

GENERAL

MODEL: DCM-120KE(-P)				TITLE: F. WATER CIRCUIT			
INDEX NO.	DESCRIPTION	MATERIAL OR MODEL NUMBER	PART NUMBER	REQ'D NUMBER			
				B-1	B-2	B-3	
24	HOSE (115) - EVA INLET		374940R01	1	1	1	
25	CAP		417323-01	1	1	1	
26	VALVE BRACKET		377145M01	1	-		
			377713M01		1	1	
27	T2 TRUSS HEAD SCREW		FT20408F0	2	-		
28	TRUSS HEAD SCREW		FST0508F0	2	2	2	
29	COVER		463633-01	1	1	1	
30	TRUSS HEAD SCREW		FST0408F0		4	4	

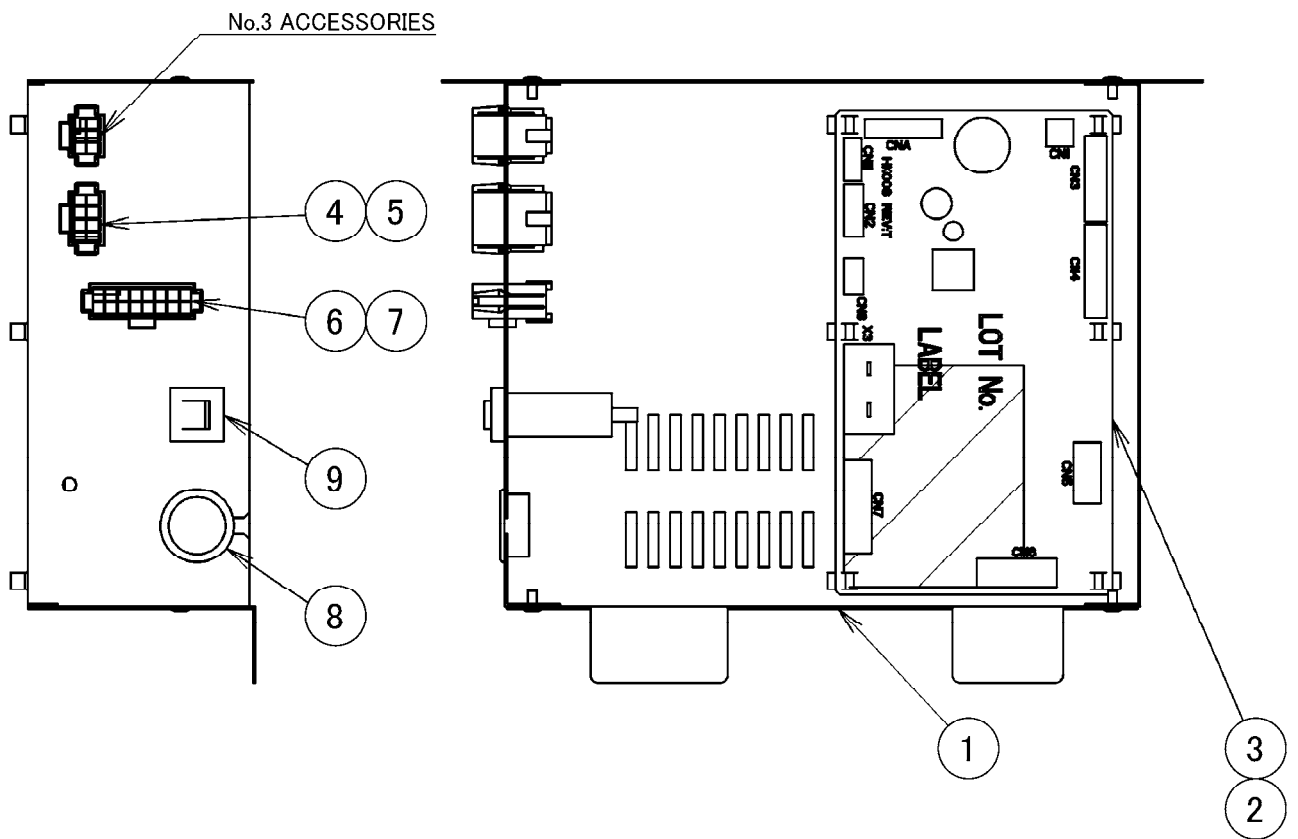
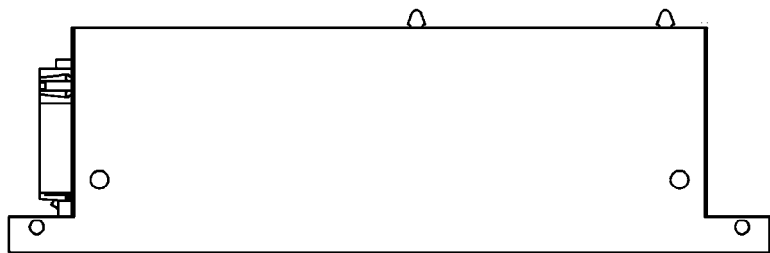

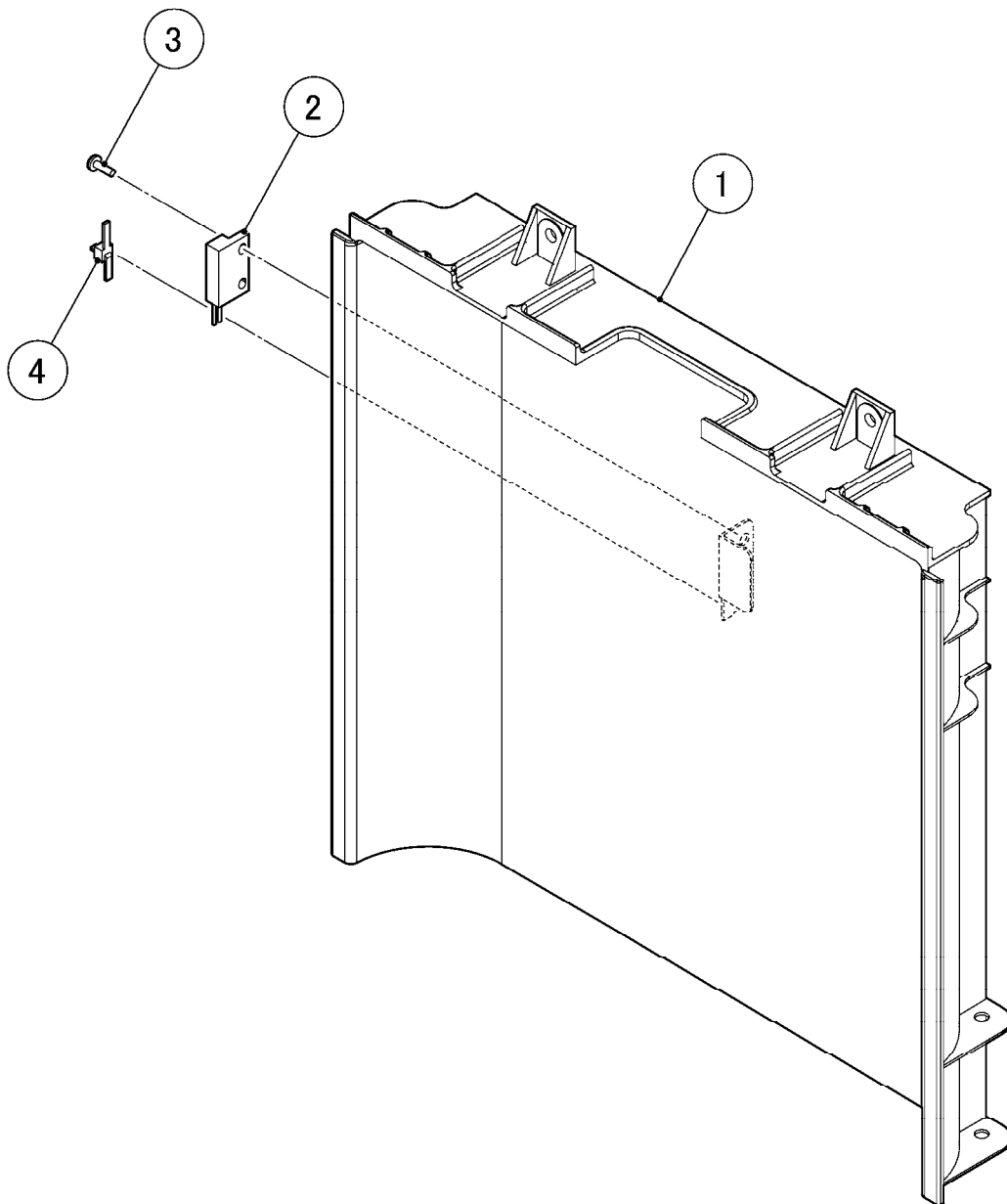

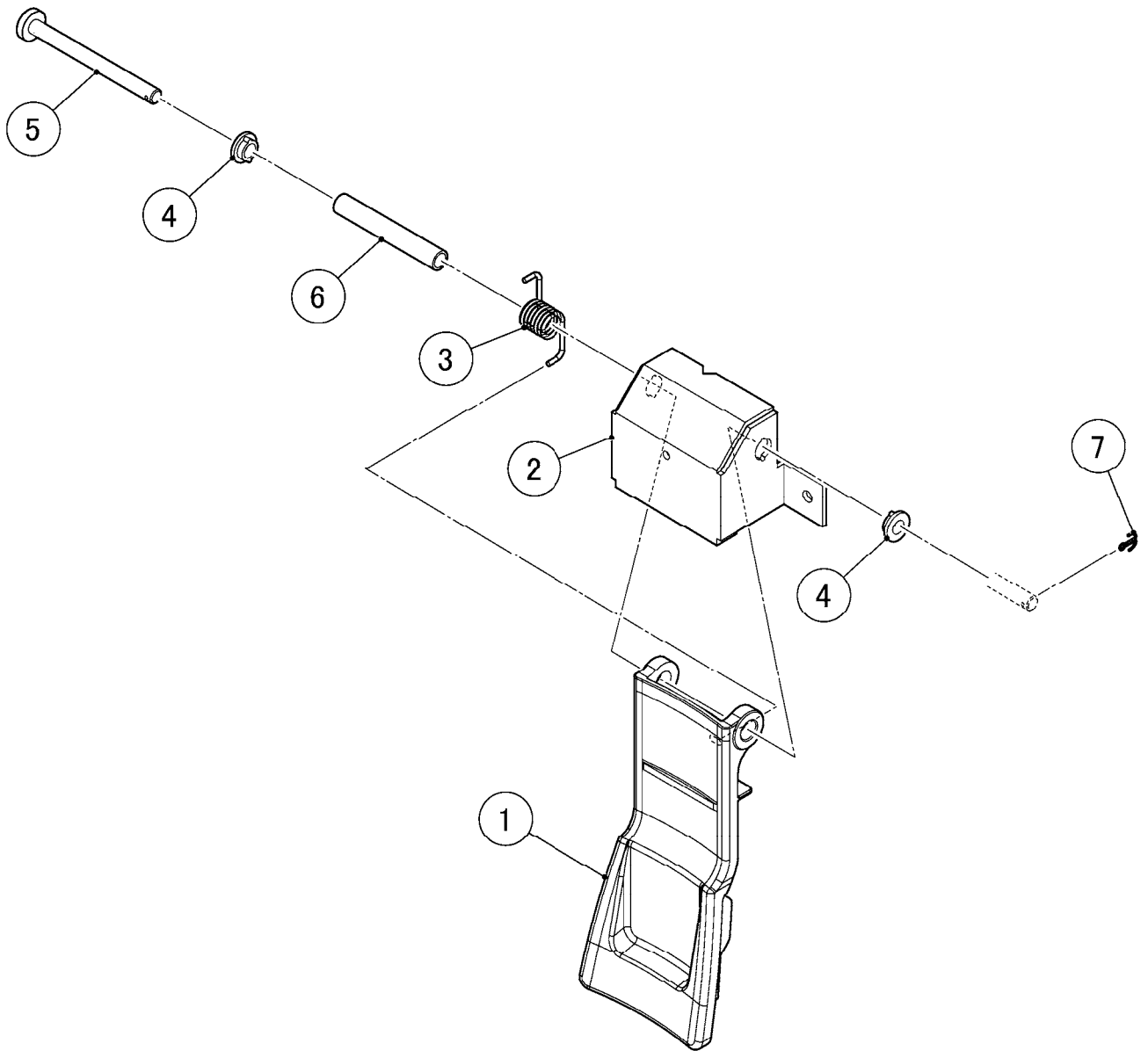

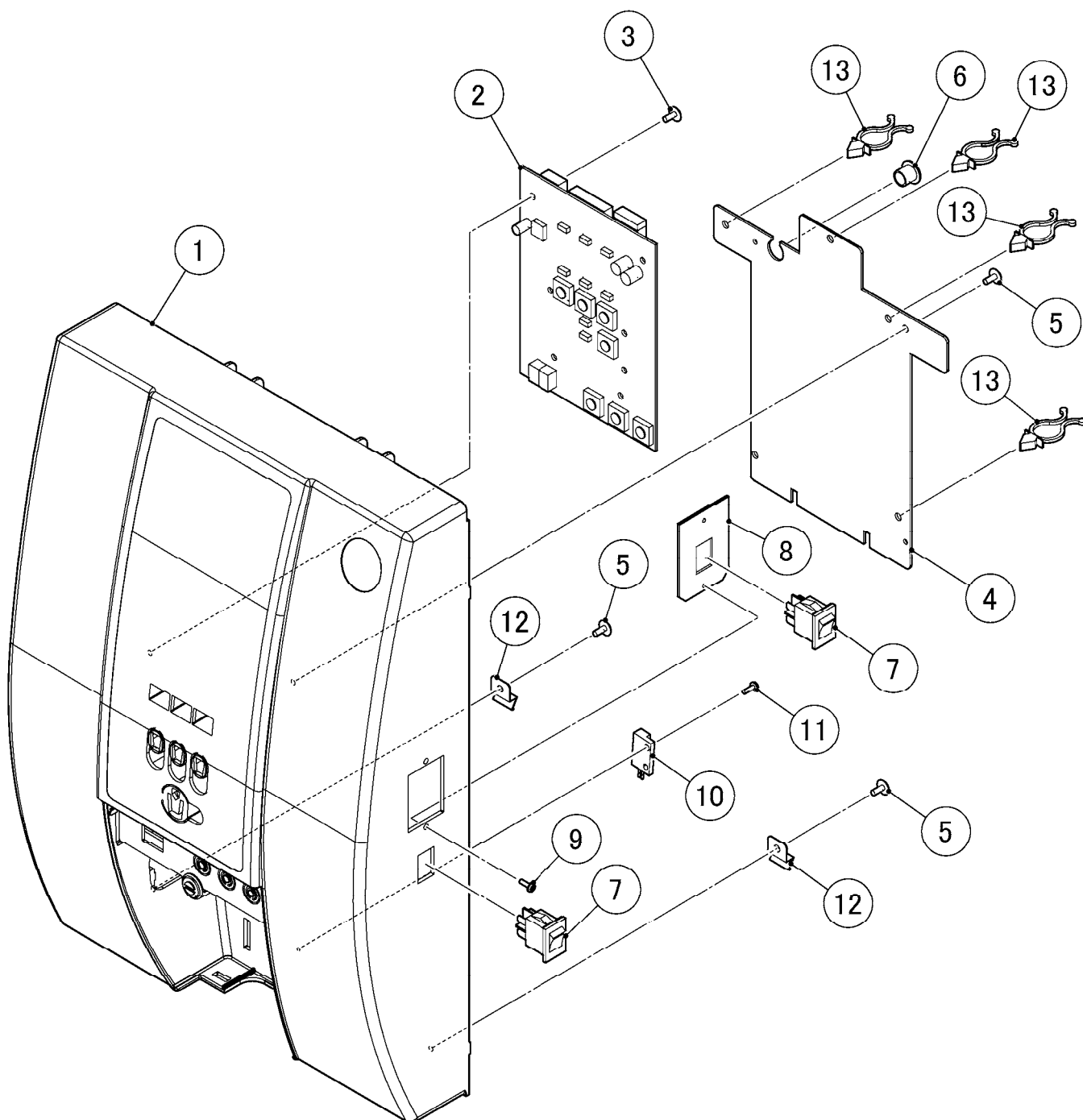

GENERAL

MODEL: DCM-120KE(-P)				TITLE: K. FRONT PANEL (UP)			
INDEX NO.	DESCRIPTION	MATERIAL OR MODEL NUMBER	PART NUMBER	REQ'D NUMBER			
				B-1	B-2	B-3	
1	FRONT PANEL (UPG) - 115		261886G01	1	1	1	
2	OPERATION BOARD - 10DCM		P02108-01	1	1	1	
3	T2 TRUSS HEAD SCREW P		FT70408M0	7	7	7	
4	COVER - OPERATION		376458M01	1	1	1	
5	T2 TRUSS HEAD SCREW		FT20408S0	4	4	4	
6	BUSHING		428394-02	1	1	1	
7	ROCKER SWITCH		P02696-01	2	2	2	
8	BRACKET - SWITCH		476734M01	1	1	1	
9	SCREW - BLACK		P02648-01	2	2	2	
10	REED SWITCH		431788-01	1	1	1	
11	PAN HEAD TAPPING SCREW T2		FT50308M0	2	2	2	
12	HOOK/FRONT		475487M01	2	2	2	
13	WIRE RETAINER	No.4253	427902-05	4	4	4	

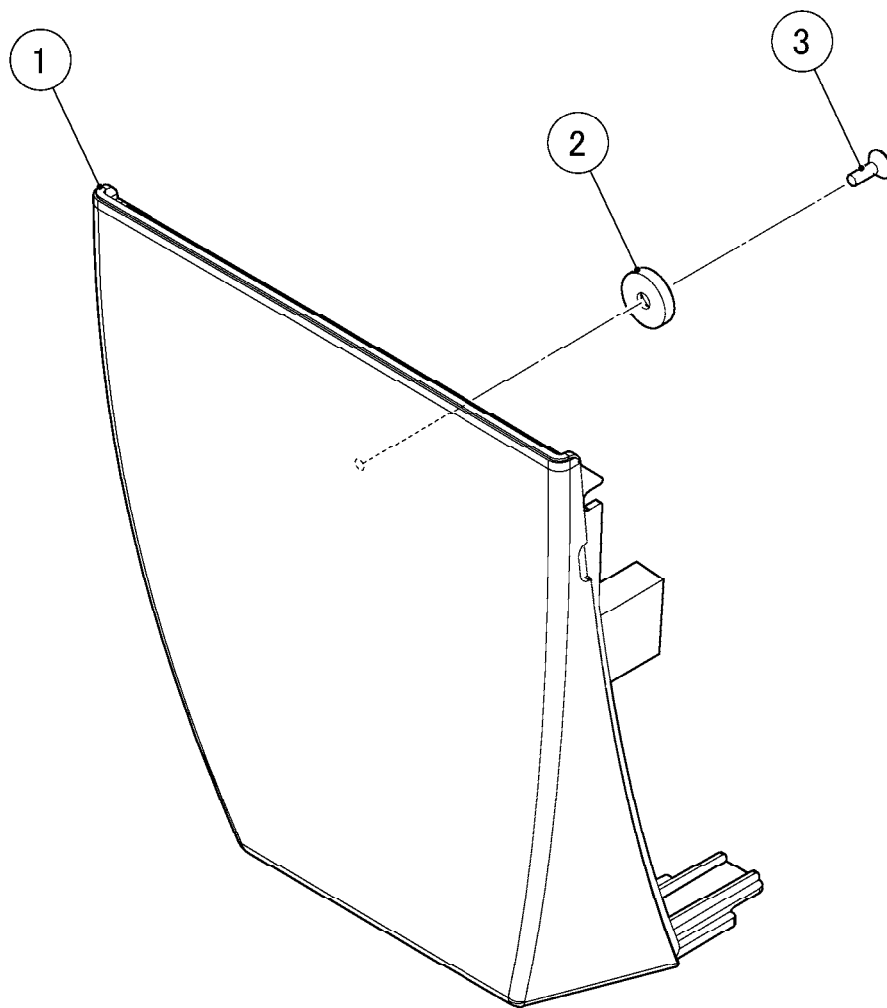

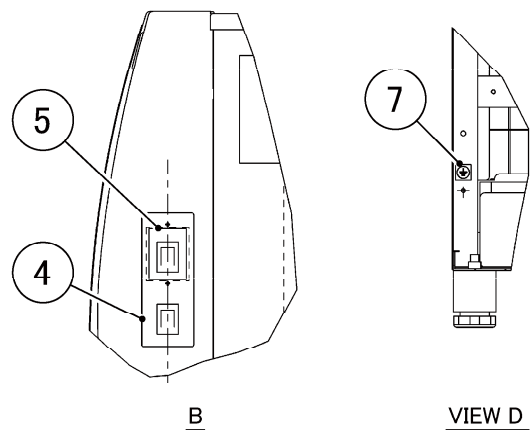
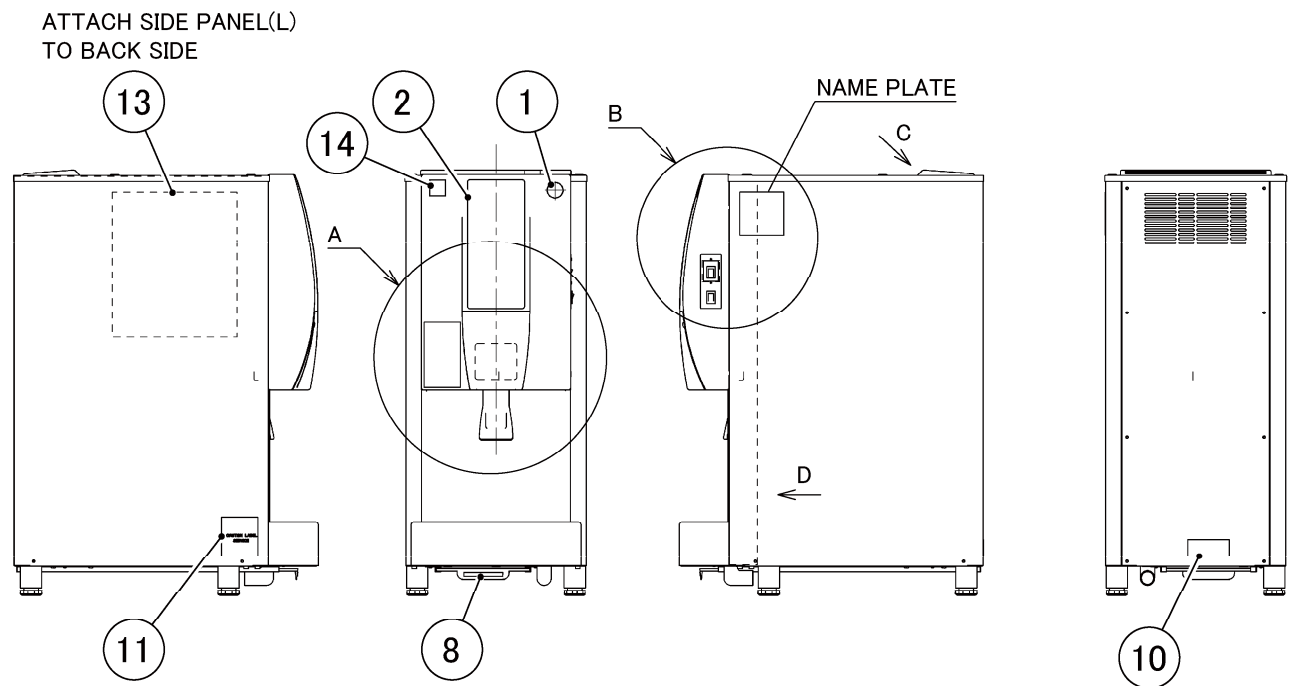
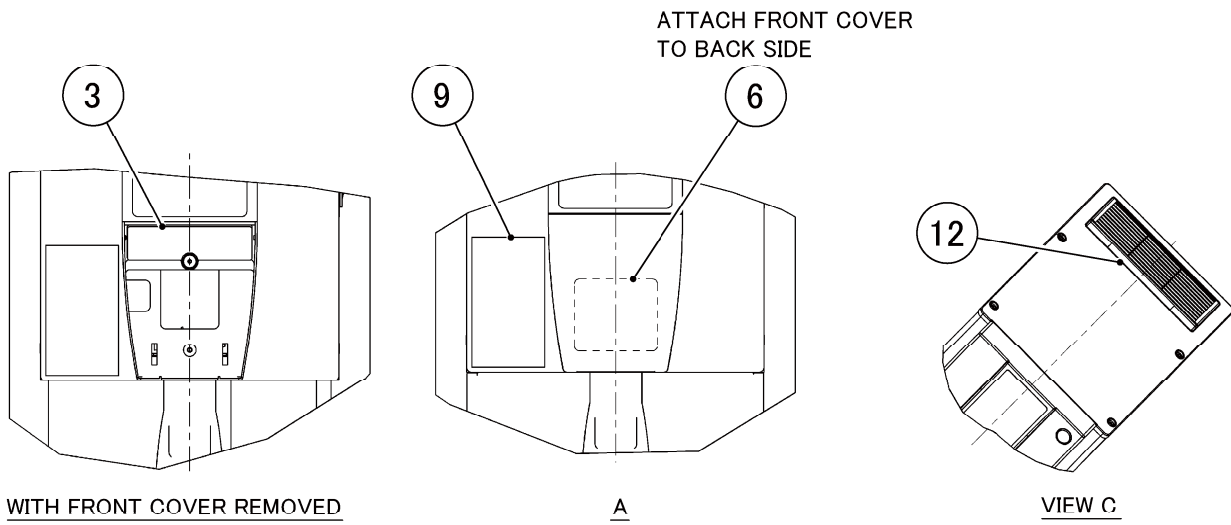

GENERAL

MODEL: DCM-120KE(-P)				TITLE: M. LABEL LOCATION			
INDEX NO.	DESCRIPTION	MATERIAL OR MODEL NUMBER	PART NUMBER	REQ'D NUMBER			
				B-1	B-2	B-3	
1	LABEL - PENGUIN		477394L01	1	1	1	
2	OPERATION LABEL		376361L01	1	1	1	
		DCM-120KE-P	376361L02	1	1	1	
3	CONTROL LABEL		376358L01	1	1	1	
4	LABEL-POWER SUPPLY A		476672L01	1	1	1	
5	LABEL-POWER SUPPLY B		476718L01	1	1	1	
6	LABEL-SPOUT		476671L01	1	1	1	
7	LABEL - EARTH (B)		450452-02	1	1	1	
8	LABEL - AIR FILTER		452799-01	1	1	1	
9	WARNING LABEL		376359L01	1	1	1	
10	CAUTION LABEL		476902L01	1	1	1	
11	CAUTION LABEL - SERVICE		471180L01	1	1	1	
12	CAUTION LABEL		477575L01	1	1	1	
13	WIRING LABEL		262508L01	1	1	1	
14	LABEL - HACCP		476519L01	1	1	1	

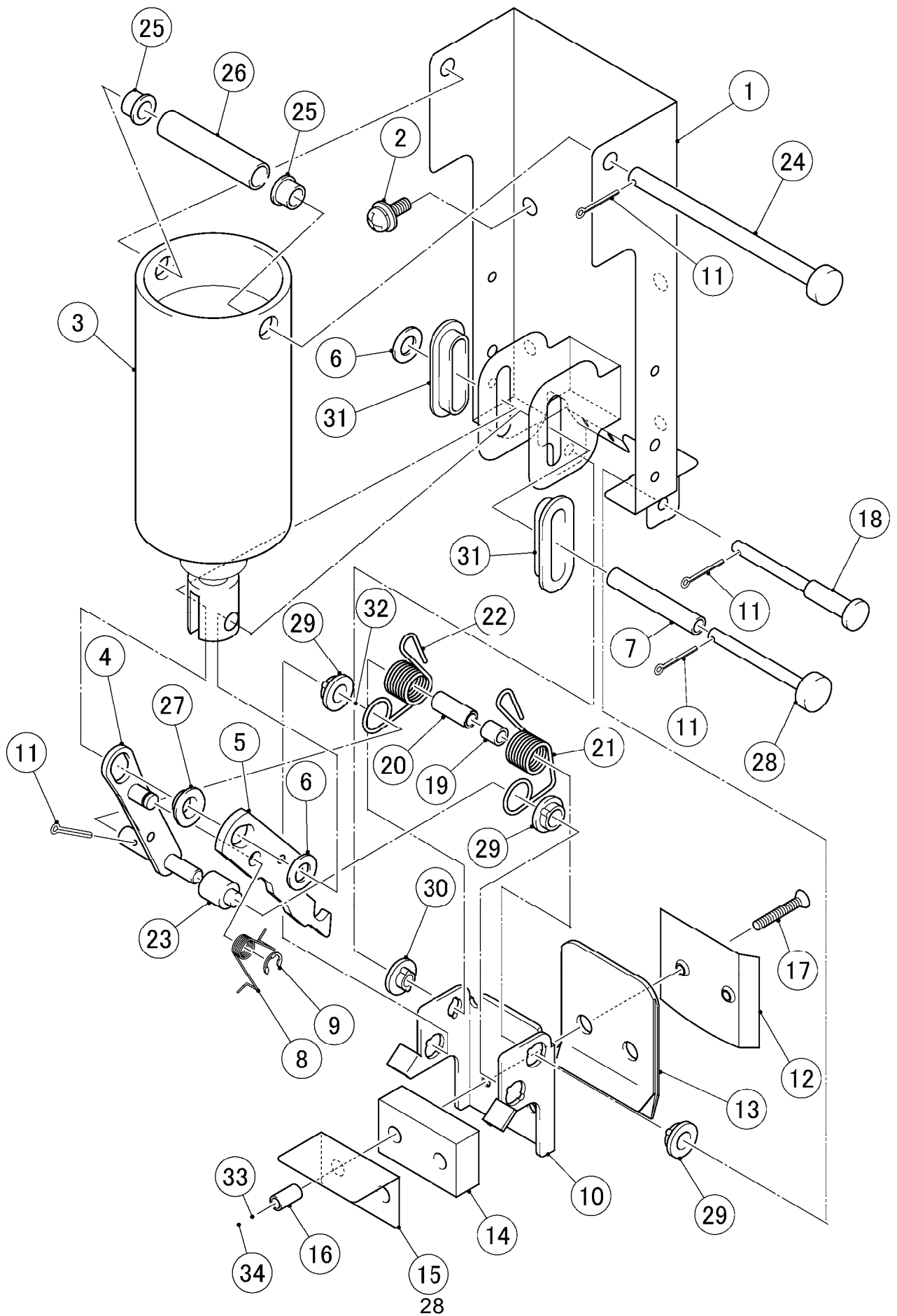

GENERAL

MODEL: DCM-120KE(-P)				TITLE: N. SHUTTER ASSY			
INDEX NO.	DESCRIPTION	MATERIAL OR MODEL NUMBER	PART NUMBER	REQ'D NUMBER			
				B-1	B-2	B-3	
1	BRACKET - SOLENOIDO		351479G01	1	1	1	
2	SCREW		434838-02	4	4	4	
3	SOLENOID		P02647-01	1	1	1	
4	SHAFT		462262G01	1	1	1	
5	HOOK - SHUTTER		438406-02	1	1	1	
6	SPACER		454943-01	2	2	2	
7	TUBE		451284-06	1	1	1	
8	SPRING		411532-01	1	1	1	
9	ERING		721S-0004	1	1	1	
10	STOPPER		351480-01	1	1	1	
11	SPLIT PIN		711SP1612	4	4	4	
12	SHUTTER PLATE (A1)		414756-01	1	1	1	
13	PLATE (B) - SHUTTER		466047-01	1	1	1	
14	CUSHION		419150-01	1	1	1	
15	PLATE (D) - SHUTTER		466063-01	1	1	1	
16	SHUTTER COLLAR (C)		411539-03	2	2	2	
17	SCREW		441581-01	2	2	2	
18	SHAFT (B)		462561-01	1	1	1	
19	TUBE		451284-05	1	1	1	
20	COLLAR		454942-01	1	1	1	
21	SPRING (R)		452502-01	1	1	1	
22	SPRING (L)		452503-01	1	1	1	
23	SHAFT (B2)		432520-02	1	1	1	
24	SHAFT - SOLENOID		462257-01	1	1	1	
25	BUSH		462558-02	2	2	2	
26	COLLAR - SOLENOID		462559-01	1	1	1	
27	SPACER (D)		461233-01	1	1	1	
28	SHAFT - PLUNGER		462258-01	1	1	1	
29	SPACER (A)		461230-01	3	3	3	

GENERAL

MODEL: DCM-120KE(-P)				TITLE: N. SHUTTER ASSY			
INDEX NO.	DESCRIPTION	MATERIAL OR MODEL NUMBER	PART NUMBER	REQ'D NUMBER			
				B-1	B-2	B-3	
30	SPACER (B)		461231-01	1	1	1	
31	SPACER(C)		461232-01	2	2	2	
32	FLAT WASHER		FWPL06S0	1	1	1	
33	FLAT WASHER		FWPL03S0	2	2	2	
34	NUT		FNH103S0	4	4	4	

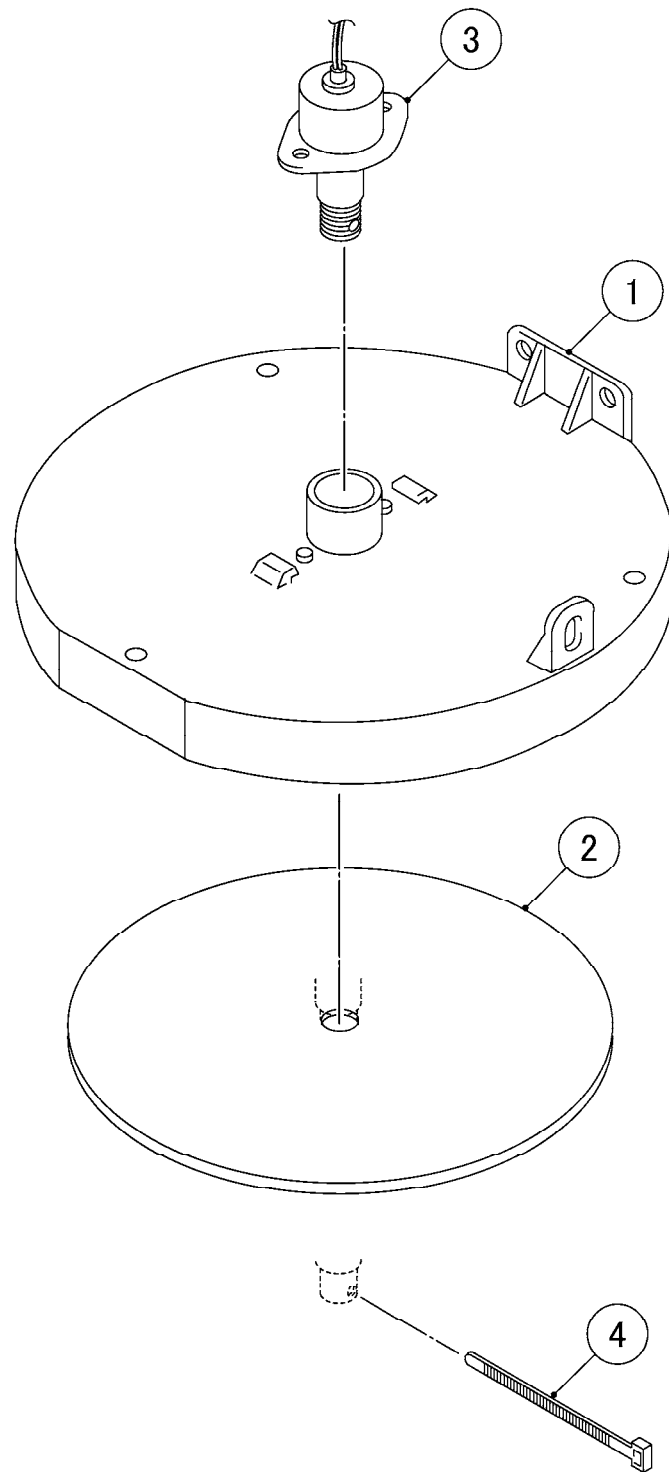

GENERAL

MODEL: DCM-120KE(-P)								TITLE: P. COVER ASSY - BIN TOP			
INDEX NO.	DESCRIPTION	MATERIAL OR MODEL NUMBER	PART NUMBER	REQ'D NUMBER							
				B-1	B-2	B-3					
1	COVER - BIN TOP		341039G01	1	1	1					
2	BALANCE PLATE		454488-01	1	1	1					
3	BIN CONTROL ASSY.		459673-01	1	1	1					
4	TIE		7920-0002	1	1	1					

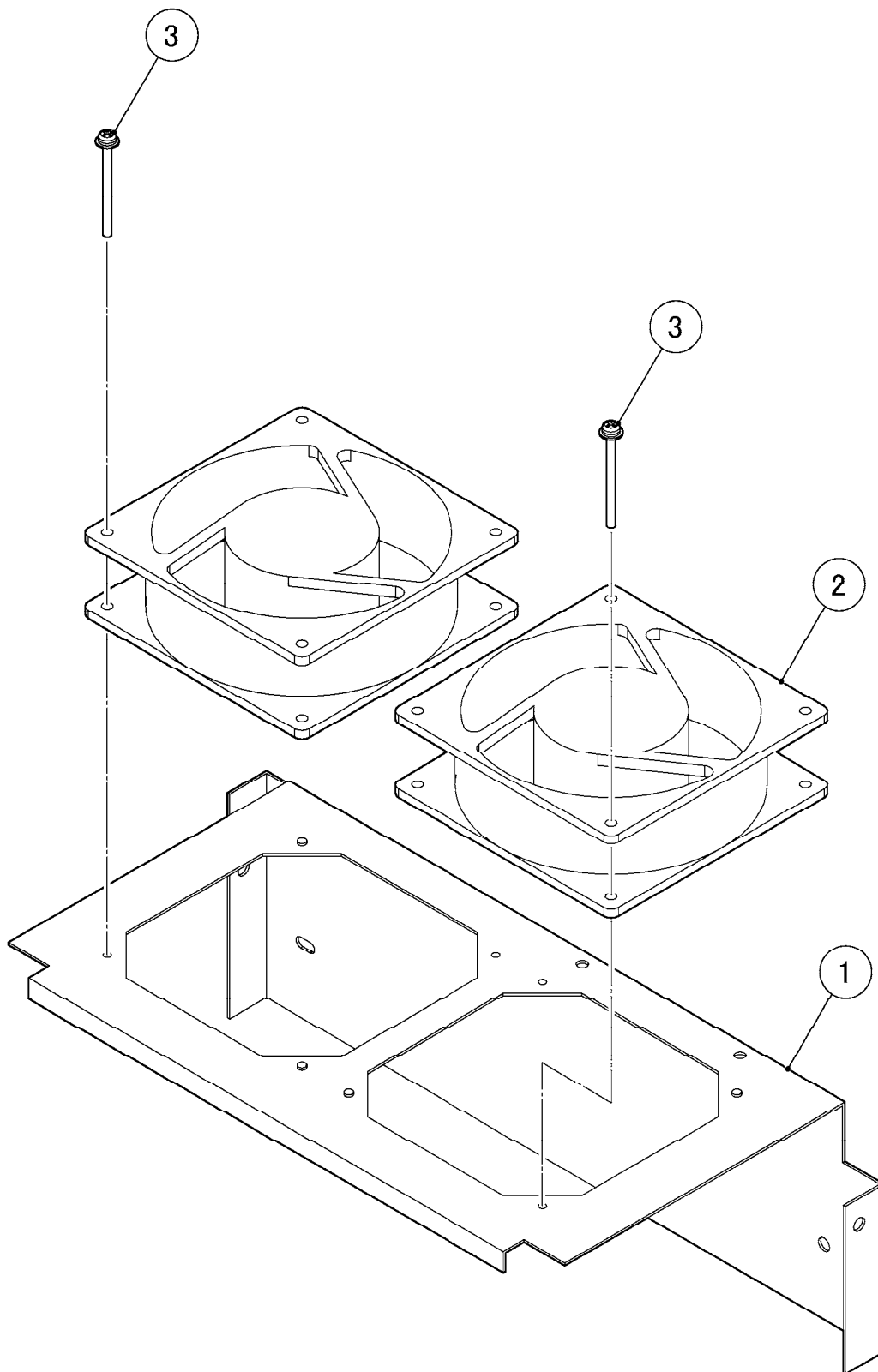

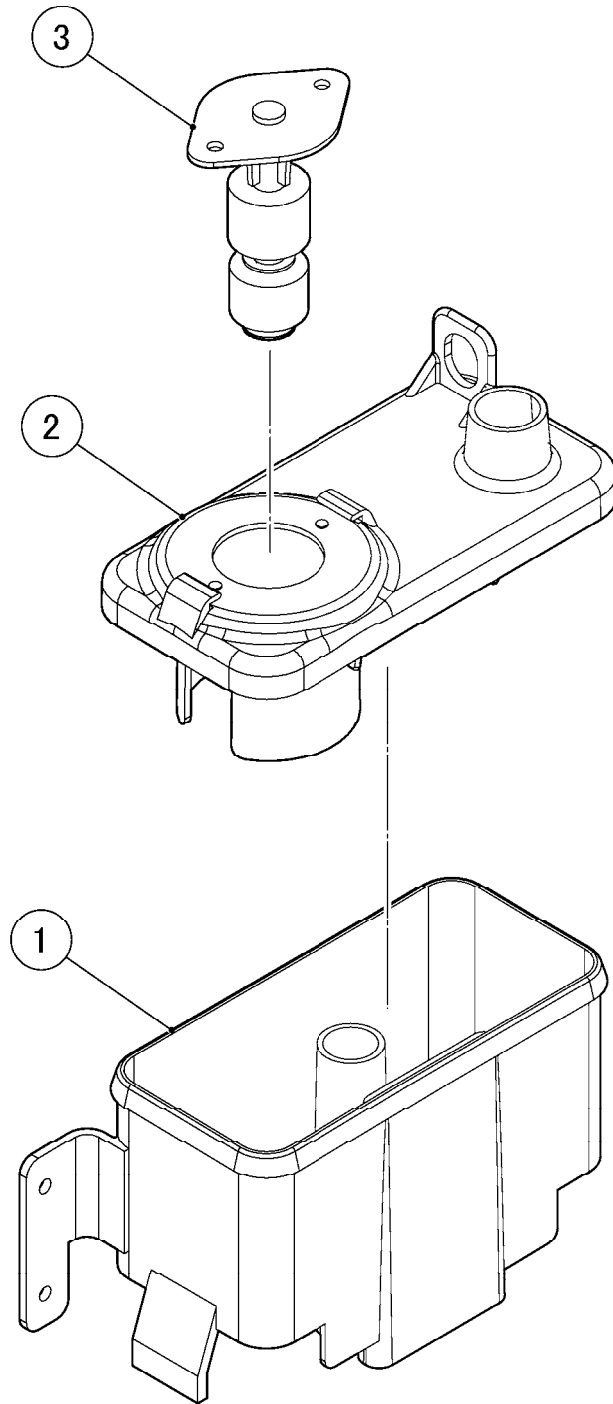

GENERAL

MODEL: DCM-120KE(-P)				TITLE: R. TANK ASSY			
INDEX NO.	DESCRIPTION	MATERIAL OR MODEL NUMBER	PART NUMBER	REQ'D NUMBER			
				B-1	B-2	B-3	
1	RESERVOIR		217620-02	1	1	1	
2	RESERVOIR COVER		217621-02	1	1	1	
3	FLOAT SWITCH		435490-01	1	1	1	

