

AM-50BAE(-AD)

SELF-CONTAINED CUBER WITH BUILT-IN STORAGE BIN

Item # _____

Project: _____

Qty: _____

*AutoCad available on KCL

AM-50BAE(-AD)

8/09

Item # 13158

CUBER DIMENSIONS W x D x H

AM-50BAE

14^{7/8} x 22^{5/8} x 33^{1/2}

AM-50BAE-AD

14^{7/8} x 22^{5/8} x 31^{1/2}

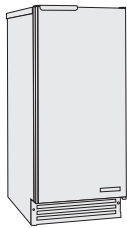

AM-50BAE

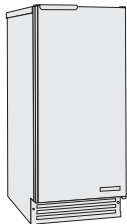

AM-50BAE-AD



AM-50BAE

Air-Cooled
Shown

AM-50BAE-AD

Air-Cooled
ADA Compliant Unit

AM-50BAE

- Undercounter design is less than 34 inches tall

AM-50BAE-AD

- Undercounter design is less than 32 inches tall, which complies with the Americans with Disabilities Act (ADA)

AM-50BAE & AM-50BAE-AD

- Up to 55 lbs. of ice production per 24 hours
- Durable stainless steel exterior
- UL approval for outdoor use
- Up to 22 lbs. of built-in storage capacity
- Power switch accessible without panel removal
- Easily disassembled water circuit for easy cleaning
- Front in, front out airflow
- Fewer moving parts for longer life
- Swing style reversible door
- Side trim kit available
- Drain pump accessory - HS-0190
- R-134A Refrigerant



Warranty

Valid in United States, Canada, Puerto Rico, & U.S. Territories. Contact factory for warranty in other countries.

Two Year - Parts & Labor on entire machine

One Year - HS-0190 Drain Pump - Parts only.



Hoshizaki

SELF-CONTAINED CUBER WITH BUILT-IN STORAGE BIN

AM-50BAE(-AD)

DIMENSIONS

W x D x H

AM-50BAE
14^{7/8} x 22^{5/8} x 33^{1/2}

AM-50BAE-AD
14^{7/8} x 22^{5/8} x 31^{1/2}

- Air-cooled
- ADA compliant

AIR-COOLED

Water Temp ° F.	50°
Air Temp ° F.	70°
	55 lbs.

UTILITY CONSUMPTION (AIR 70°F/WATER 50°F)

Model Number	Ice Production Per Cycle		KWH per 100 LBS.	Potable Water Gal. per 100 lbs.	Condenser Water Gal. per 100 lbs.
	Lbs.	Cubes			
AM-50BAE(-AD)	0.65	24	9.9	53.7	N/A

SPECIFICATIONS

Model Number	Condenser	Amperage	Min. Circuit Ampacity	Shipping Weight
AM-50BAE(-AD)	Air-Cooled	3.4	15	115 lbs.*

* Without pallet

AM CUBE DIMENSIONS

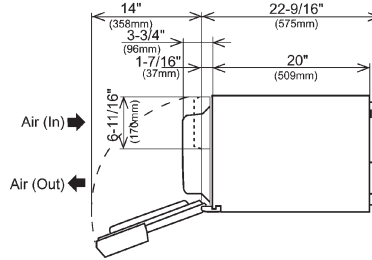
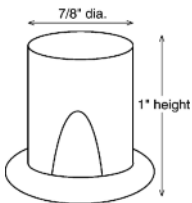

TOP DIMENSIONS

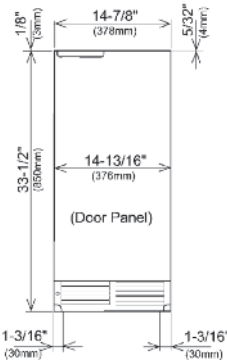

FRONT DIMENSIONS

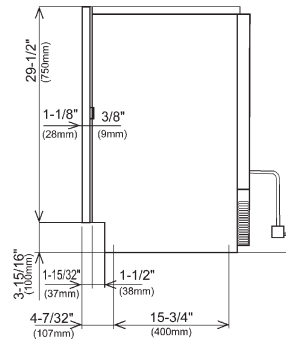

SIDE DIMENSIONS

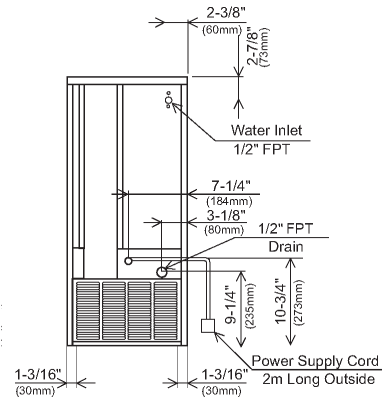

BACK DIMENSIONS

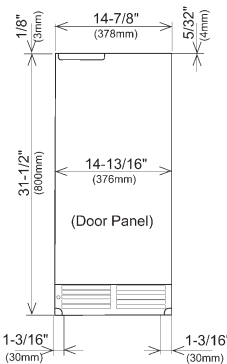

FRONT DIMENSIONS
(ADA compliant unit)

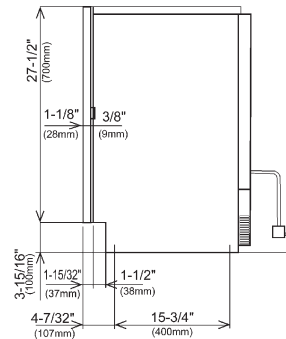

SIDE DIMENSIONS
(ADA compliant unit)

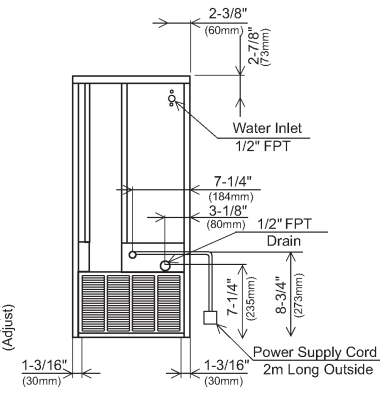

BACK DIMENSIONS
(ADA compliant unit)

ELECTRICAL & PLUMBING/AM-50BAE(-AD)

- 115V/60/1
- 15 amp Max Fuse/HACR Breaker Size
- 1/2" FPT Water Inlet
- 1/2" FPT Drain

OPERATING LIMITS

- Ambient Temp Range 45 - 100°F
- Water Temp Range 45 - 95°F
- Water Pressure 7 - 113psig
- Voltage Range 104 - 127V



© HOSHIZAKI AMERICA, INC.

6128 Hwy. 74 S., Peachtree City, GA 30269

TEL 1-800-438-6087

FAX 1-800-345-1325

www.hoshizaki.com

Printed in U.S.A.

