



FRESER INTERNATIONAL CORP.

老日光冷凍工業股份有限公司

FOOD AND BEVERAGE SOLUTIONS

retigo<sup>®</sup>  
*Vision*

**model**  
**B623**

萬能蒸烤箱  
零件分解圖

COMBI OVEN  
SPARE PARTS

**FRESER INTERNATIONAL**

2011/09/01

# 目錄 CATALOGUE

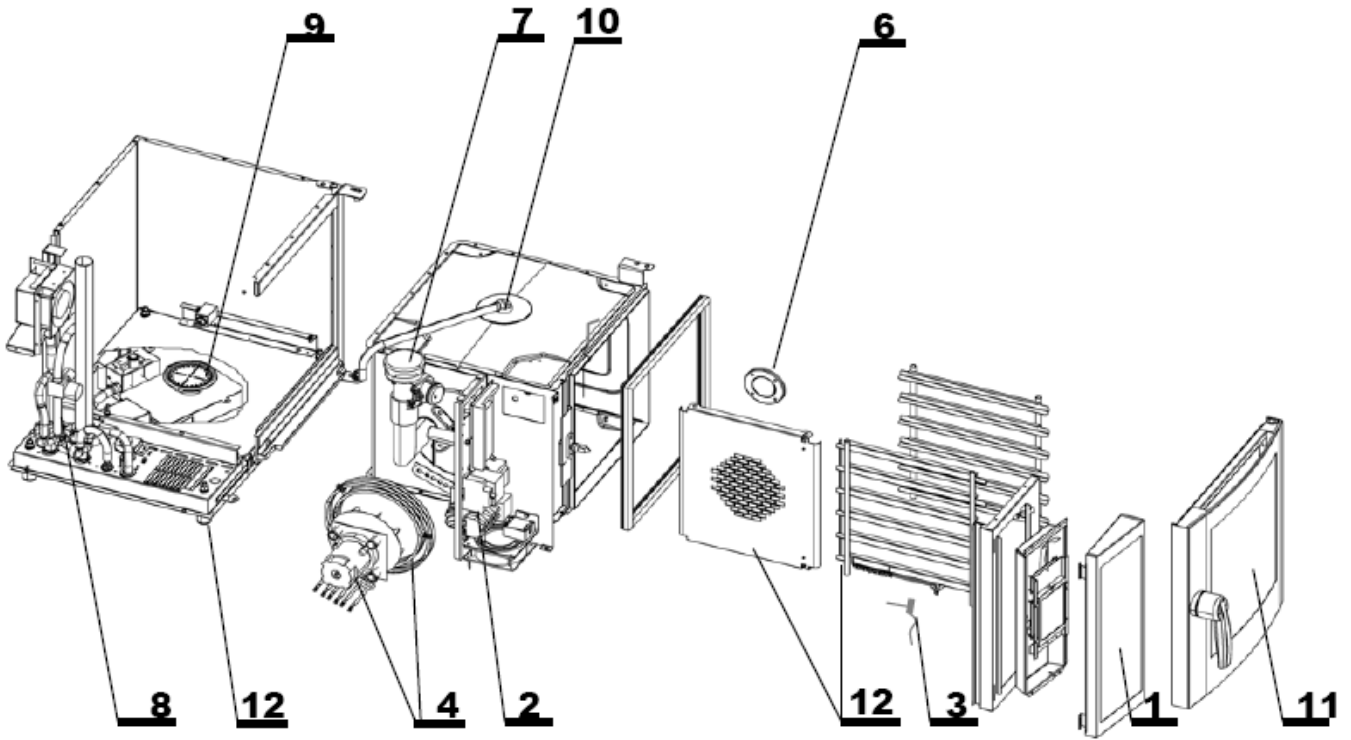

1. 控制板 CONTROL PANEL .....	P3
2. 電源板 POWER PANEL .....	P4
3. 溫度感應器 TEMPERATURE SENSOR .....	P5
4. 馬達、風扇、加熱器 MOTOR、VENTILATOR、HEATING ..	P6
6. 照明燈 LIGHT .....	P7
7. 抽濕閥 FLAP VALVE .....	P8
8. 進水系統 WATER DISTRIBUTION SYSTEM .....	P9
9. 排水系統 DRAINAGE SYSTEM .....	P10
10. 自動清潔系統 AUTOMATIC CLEANING SYSTEM .....	P11
11. 門 DOOR .....	P12
12. 組件 ACCESSORIES .....	P13

# 1. 控制板 CONTROL PANEL

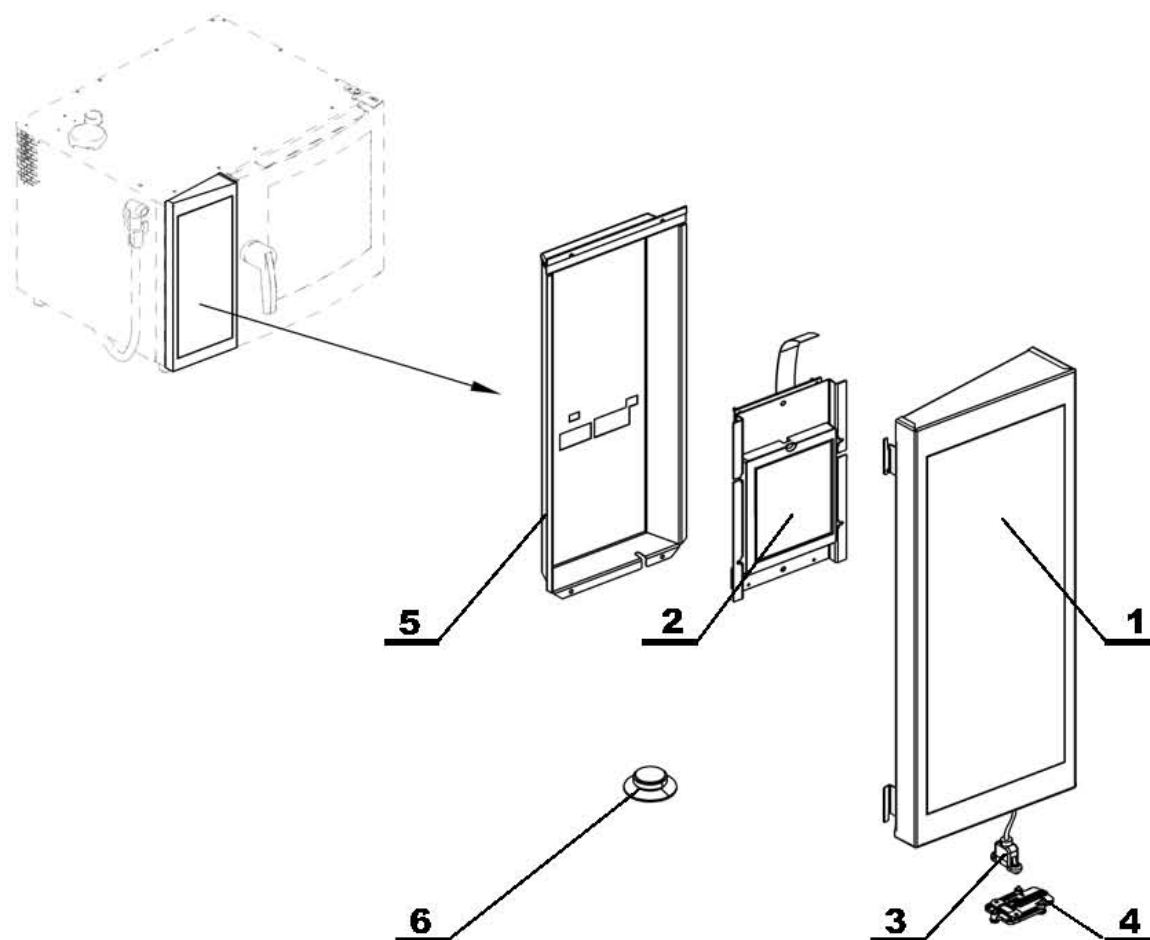

1Item 圖 號	Part N 料 號	English name	中文品名	機 型	
				B623i	
1	AC21-1505/S	LEFT CORNER PLATE 623 – BLUE WITH USB CONNECTOR	控制板框架 (含 USB 連接器)	●	
1	AC21-1505	WHOLE LEFT CORNER WITH ELECTRONIC 623 – BLUE	控制板(含框架)	●	
2	XC10-1800	ELECTRONIC BOARD SET VISION BLUE 2009	控制板	●	
3	EA05-0052	USB CABLE	USB 連接線	●	
4	SP21-0001	USB COVER	USB 外蓋	●	
5	AP10-0021	CONTROL BOARD BACK WALL	控制板背板	●	
6	EA13-0151	AUXILIARY LOUDSPEAKER	揚聲器	●	

## 2. 電源板 POWER PANEL

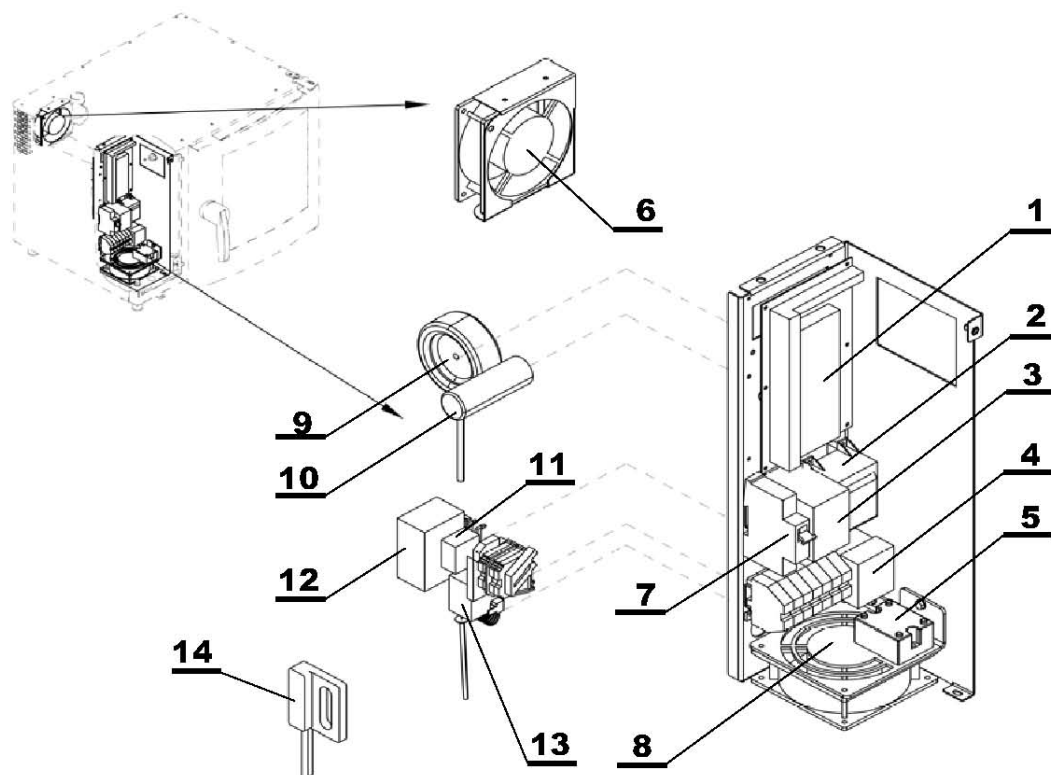

Item 圖 號	Part N 料 號	English name	中文品名	機 型	
				B623i	
1	EA14-0060	POWER SUPPLY BOARD VISION RP20.B.15	電源板	●	
2	EA13-0008	TRANSFORMER 17V	變壓器 17V	●	
3	EA01-0101	THERMAL RELAY	電磁接觸器(有覆歸鈕)	●	
4	EA02-0001	CONTACTOR	電磁接觸器	●	
5	EA02-0203	SOLID STATE RELAY	固態繼電器	●	
6	ZA21-0007	FAN	風扇	●	
7	EA03-0016	CIRCUIT BREAKER	斷路開關	●	
8	ZA21-0007	FAN	風扇	●	
9	EA13-0010	TRANSFORMER 230V/11.5V	變壓器 230V/11.5V	●	
10	EA13-0301	STARTING CAPACITOR	風扇達啟動電容	●	
11	EA13-0056	SUPPRESSION COMPONENT		●	
12	EA13-0057	SUPPRESSION COMPONENT		●	
13	EA04-0012	THERM. FUSE FOR SPACE 360 °C	內箱安全限溫器	●	
14	EA01-0015	DOOR SWITCH	門開關	●	

### 3.溫度感應器 TEMPERATURE SENSOR

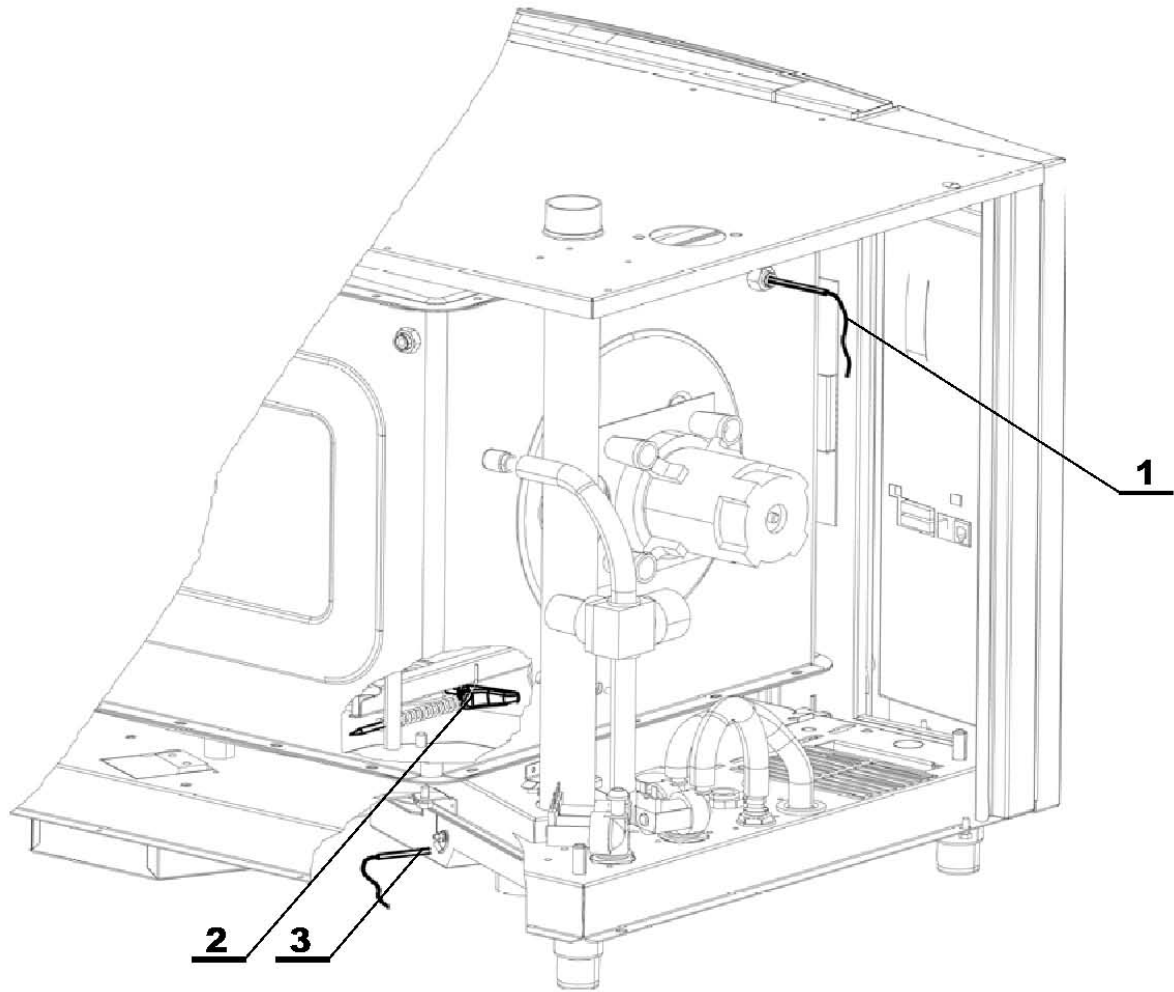

Item 圖 號	Part N 料 號	English name	中文品名	機 型	
				B623i	
1	EA10-0103	SHEATED THERMOMETER VISION	內箱溫度感應器	●	
2	EA10-0114	THERMOCOUPLE PROBE VISION	中心溫度探針	●	
3	EA10-0104	THERMOCOUPLE CABLE VISION-FOR BOILER	鍋爐溫度感應器	●	

## 4. 馬達、風扇、加熱器

### MOTOR、VENTILATOR、HEATING

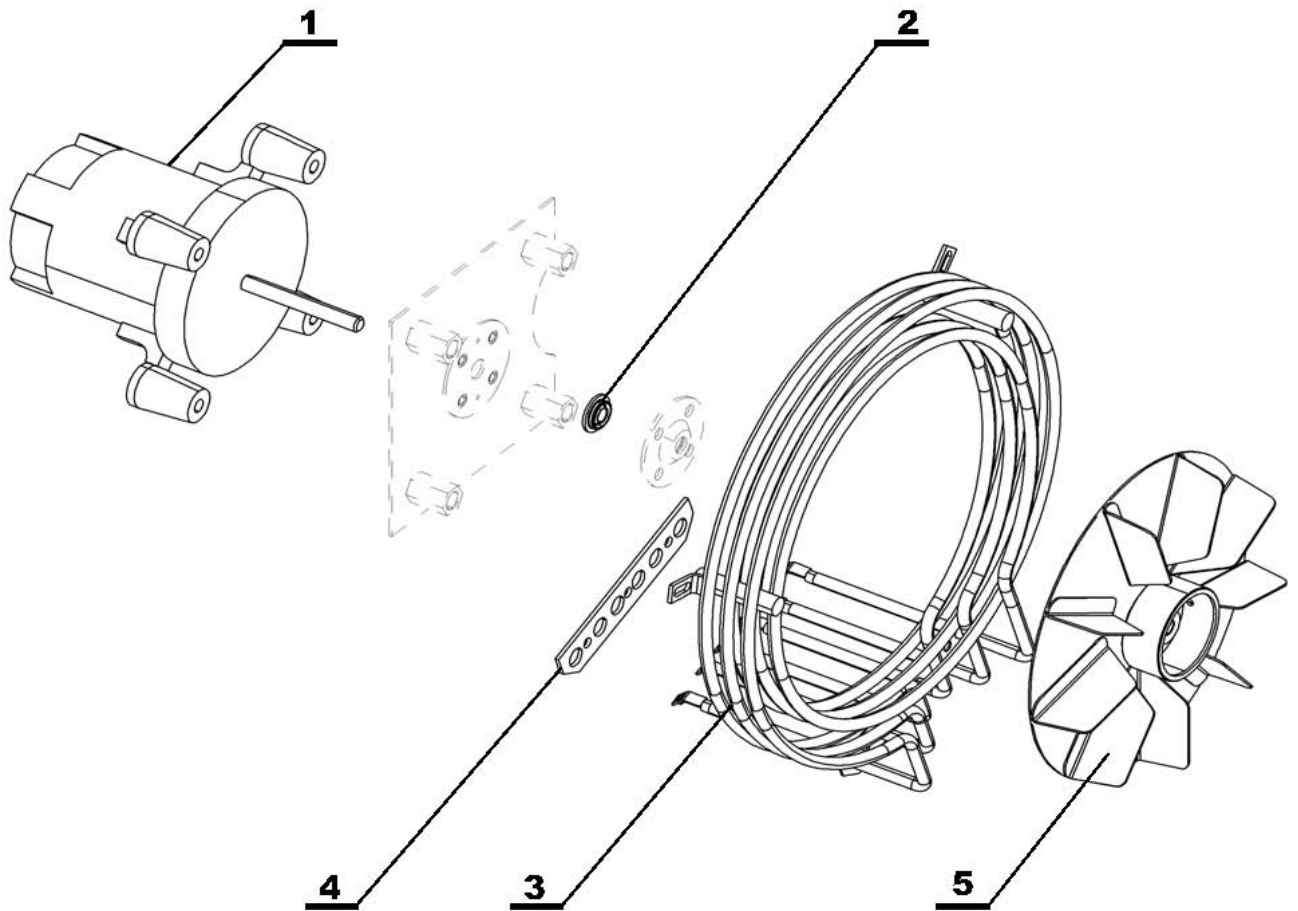

Item 圖 號	Part N 料 號	English name	中文品名	機 型	
				B623i	
1	EA11-0004	ELECTROMOTOR	風扇馬達	●	
2	AX00-0011	MOTOR SEAL	馬達軸封	●	
3	EX00-0016	SPACE HEATING ELEMENT 4800 W	內箱加熱器	●	
4	AX00-0017	SEAL	內箱加熱器墊片	●	
5	AX09-0004	VENTILATOR FAN	風扇	●	

## 6. 照明燈 LIGHT

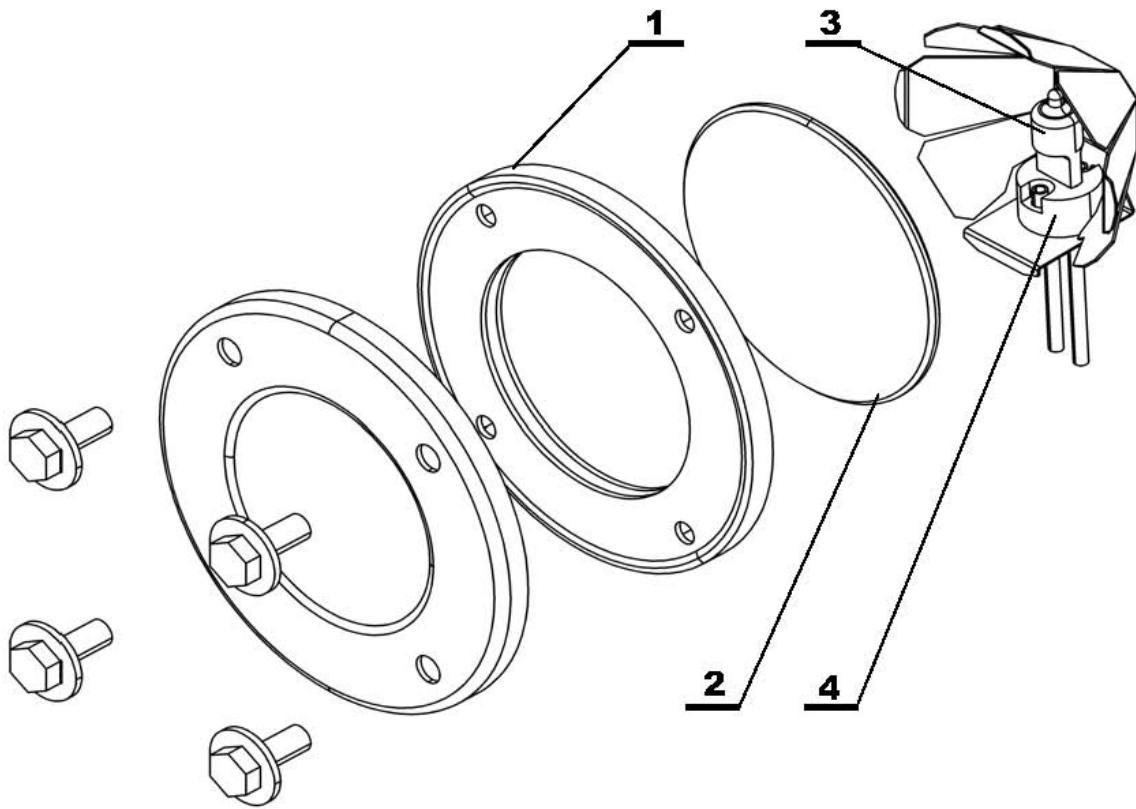

Item 圖 號	Part N 料 號	English name	中文品名	機 型	
				B623i	
1	AX07-0005	LIGHT SEAL VISIOB	照明燈墊片	●	
2	AX07-0004	GLASS PLATE	照明燈玻璃蓋	●	
3	EX13-0100	HALOGEN LIGHT	照明燈	●	
4	EX13-0101	HOLOGEN LIGHT BASE	照明燈座	●	

## 7. 抽濕閥 FLAP VALVE

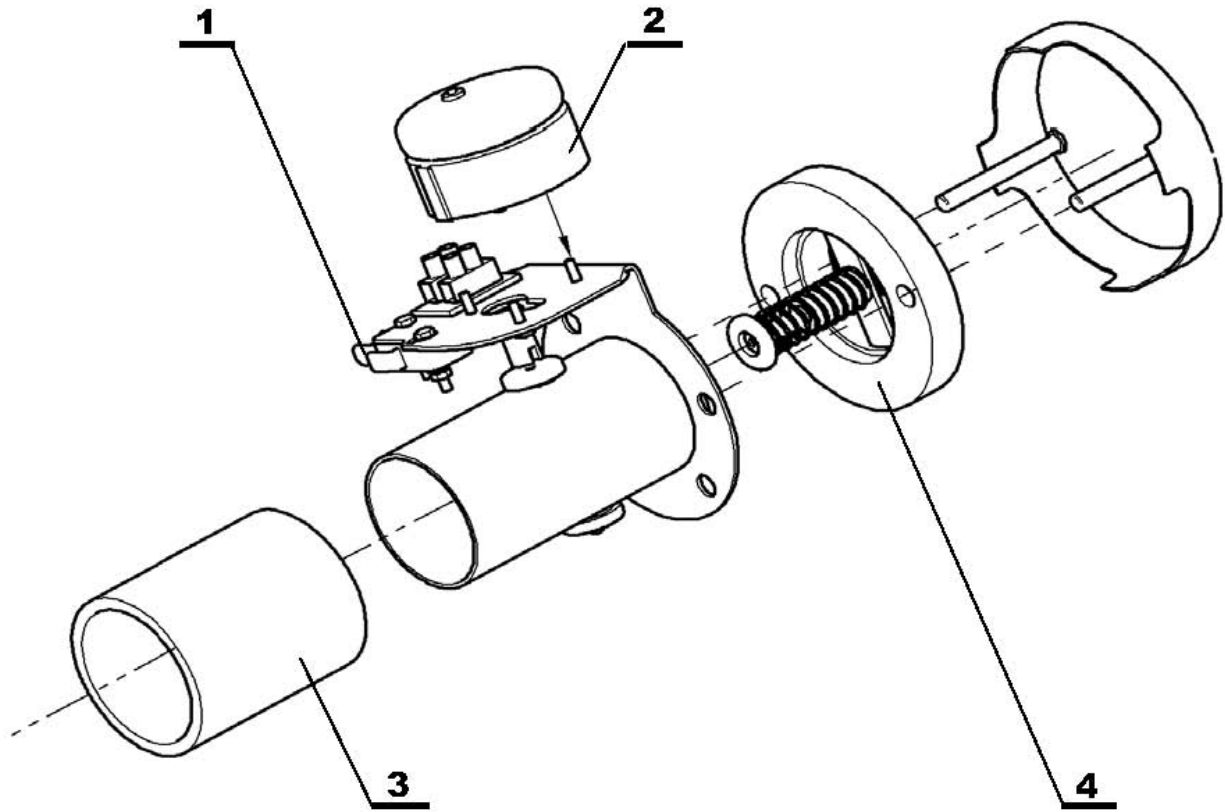

Item 圖 號	Part N 料 號	English name	中文品名	機 型	
				B623i	
1	EA01-0052	MICROSWITCH	抽濕閥微動開關	●	
2	EA11-0012	MOTOR	抽濕閥馬達	●	
3	AT00-0006	FLAP VALVE HOSE	抽濕閥管	●	
4	AC25-0105	PLUG	抽濕閥塞頭	●	



## 8. 進水系統 WATER DISTRIBUTION SYSTEM

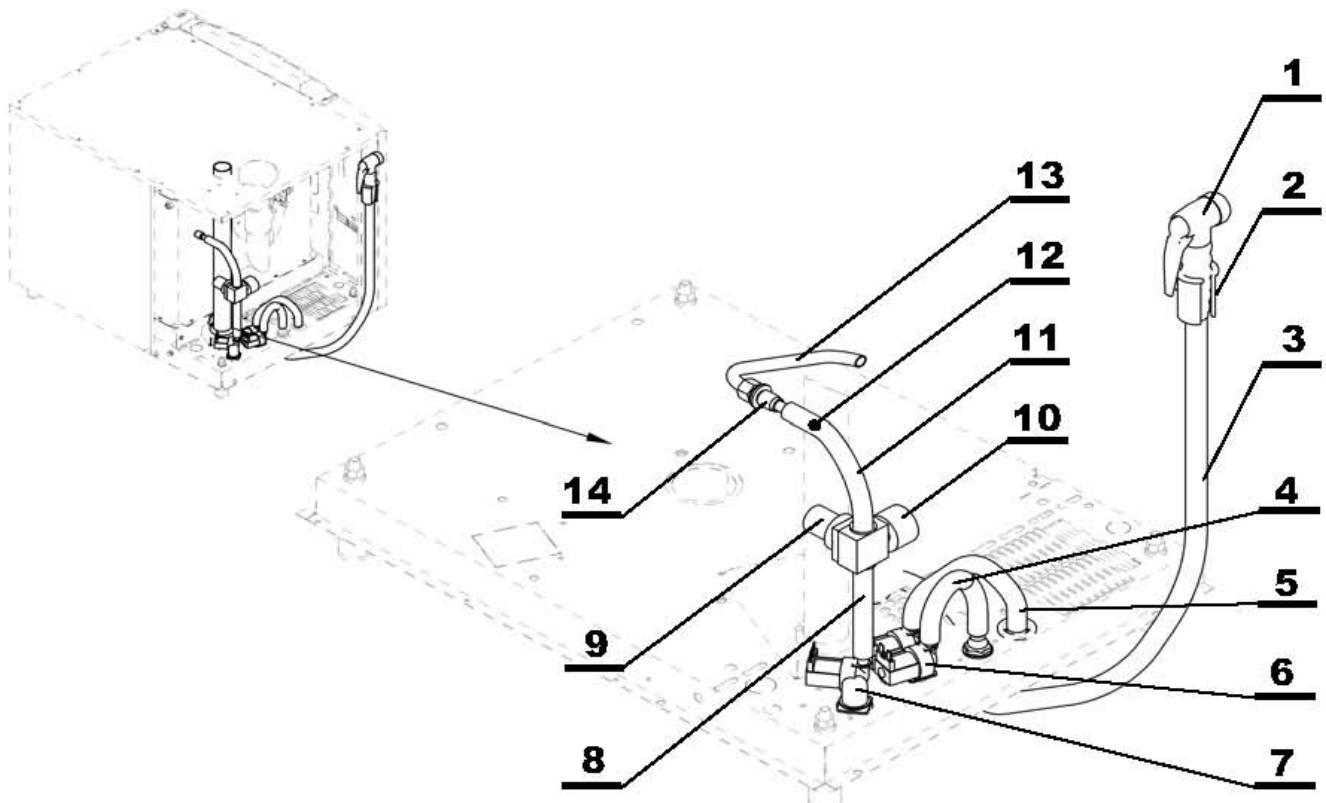

Item 圖 號	Part N 料 號	English name	中文品名	機 型	
				B623i	
1	ZA15-0100	HAND SHOWER	水槍	●	
2	AT00-0002	HAND SHOWER HOLDER	水槍架	●	
3	ZA11-0902	RUBBER HOSE FOR SHOWER 1.6m	水槍連接管 1.6 公尺	●	
4	AA26-0108	HOSE 10 x 3.6 240	進水管	●	
5	AA26-0110	HOSE 10 x 3.6 480	進水管	●	
6	EA12-0050	DOUBLE SOLENOID VALVE	雙線圈進水電磁閥	●	
7	EA12-0051	SIMPLE SOLENOID VALVE	單線圈進水電磁閥	●	
8	AA26-0104	HOSE 10 x 3.6 90	進水管	●	
9	ZA12-0201	WATER REDUCING VALVE	水壓調節閥	●	
10	ZA12-0401	MANOMETER	壓力錶	●	
11	AA26-0111	HOSE 10 x 3.6 195	進水管	●	
12	AT00-0056	NOZZLE 07	噴嘴	●	
13	AC12-0800	INJECTION PIPE VISION 623	噴霧管	●	
14	AC00-2500	BUSHING	襯套	●	

## 9. 排水系統 DRAINAGE SYSTEM

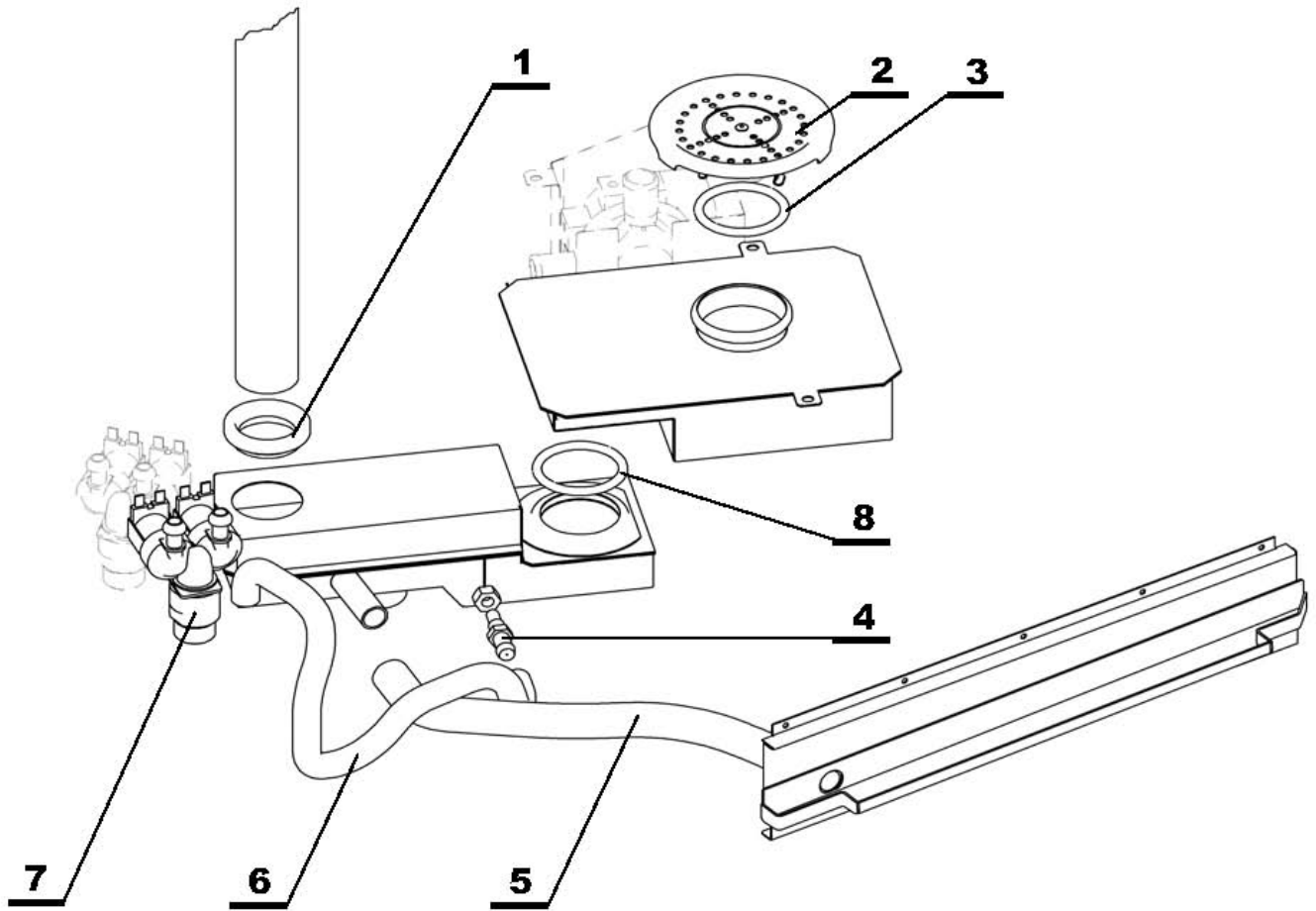

Item 圖 號	Part N 料 號	English name	中文品名	機 型	
				B623i	
1	AX04-0001	SEAL	密封圈	●	
2	AC02-2202	DRAIN CAP	排水蓋	●	
3	ZA13-1549	O-RING	O 型環	●	
4	AT01-0013	NOZZLE	噴嘴	●	
5	AA26-0156	HOSE 16/22 350	滴水槽排水管	●	
6	AA26-0110	HOSE 10 x 2.6 480	進水管	●	
7	EA12-0050	DOUBLE SOLENOID VALVE	雙線圈進水電磁閥	●	
8	EA13-1549	O-RING	O 型環	●	

# 10.自動清潔系統

## AUTOMATIC CLEANING SYSTEM

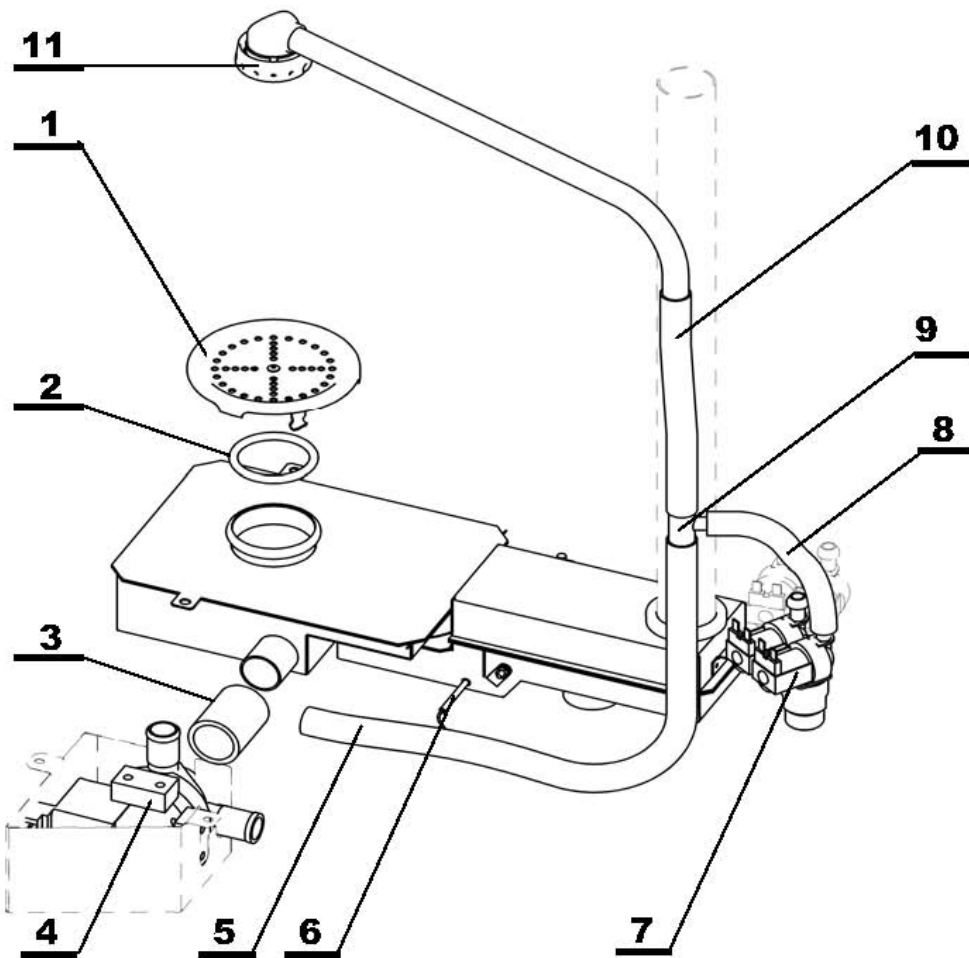

Item 圖 號	Part N 料 號	English name	中文品名	機 型	
				B623i	
1	AC02-2202	DRAIN CAP	排水蓋	●	
2	ZA13-1549	O-RING	O 型環	●	
3	AA00-0029	HOSE 50mm BLACK	排水管 5 公分(黑)	●	
4	EA12-0001	PUMP	清洗泵	●	
5	AA26-0157	HOSE 16/22 450	進水管	●	
6	EA10-0102	THERMOCOUPLE CABLE VISION	溫度感應器	●	
7	EA12-0050	DOUBLE SOLENOID VALVE	雙線圈進水電磁閥	●	
8	AA26-0108	HOSE 10 x 3.6 240	進水管	●	
9	AC32-0400	T- FITTING	三通	●	
10	AA26-0150	HOSE 16/22 230	進水管	●	
11	AAX32-0001	CLEANING NOZZLE	清洗噴頭	●	

# 11. 門 DOOR

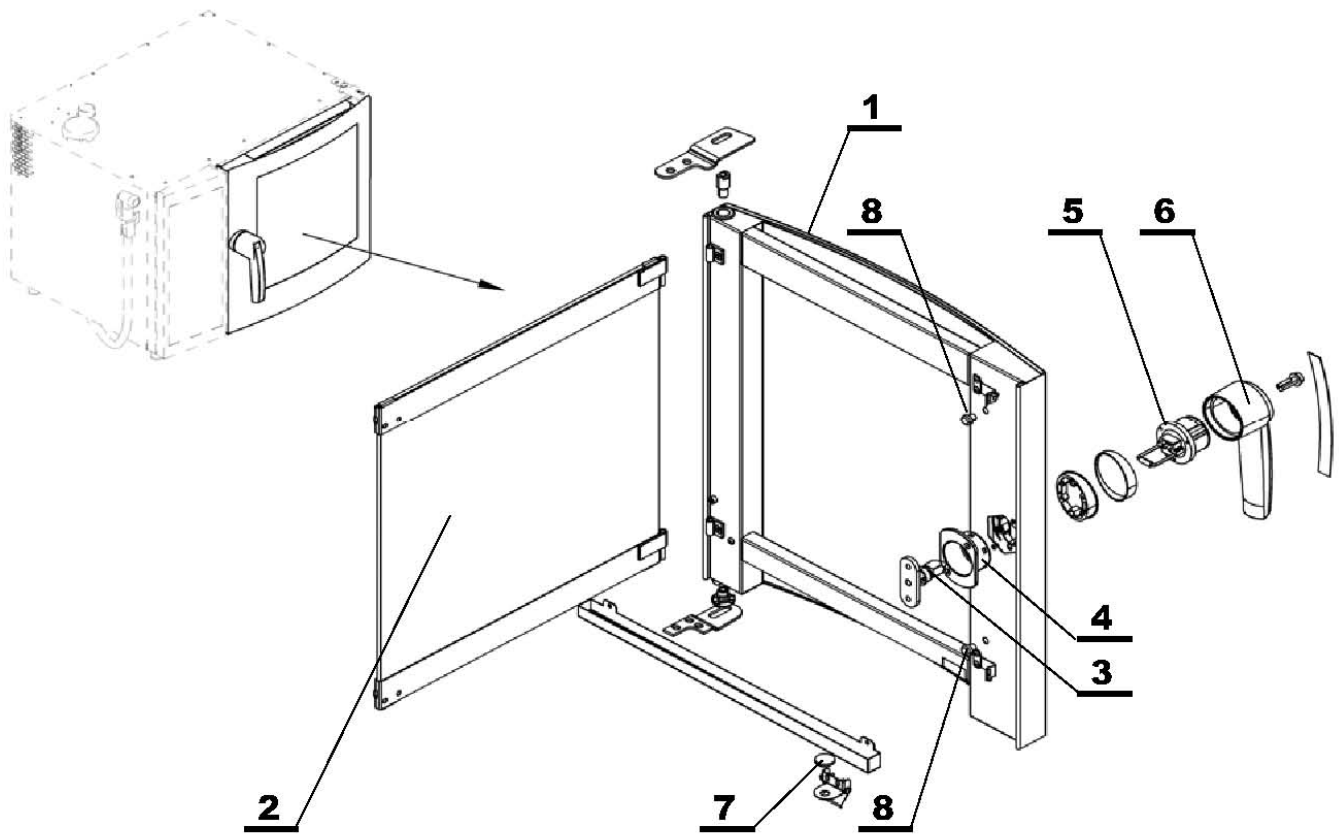

Item 圖 號	Part N 料 號	English name	中文品名	機 型	
				B623i	
1	AC03-3600	DOOR 623 97 VISION COMPLETE	玻璃門組	●	
2	AC03-3602	INTERIOR GLASS 623 07 VISION	內玻璃	●	
3	ZA20-0902	BILL KL-J	門勾	●	
4	AX08-0020	BOX	門鎖匣	●	
5	ZA20-0901	DOOR MECHANISM	門鎖	●	
6	AX08-0021	HANDLE VISION	門把手	●	
7	ZA13-0516	STOPPER	門擋片	●	
8	AX03-0076	WINDOWS STOP	內玻璃擋片	●	

## 12. 組件 ACCESSORIES

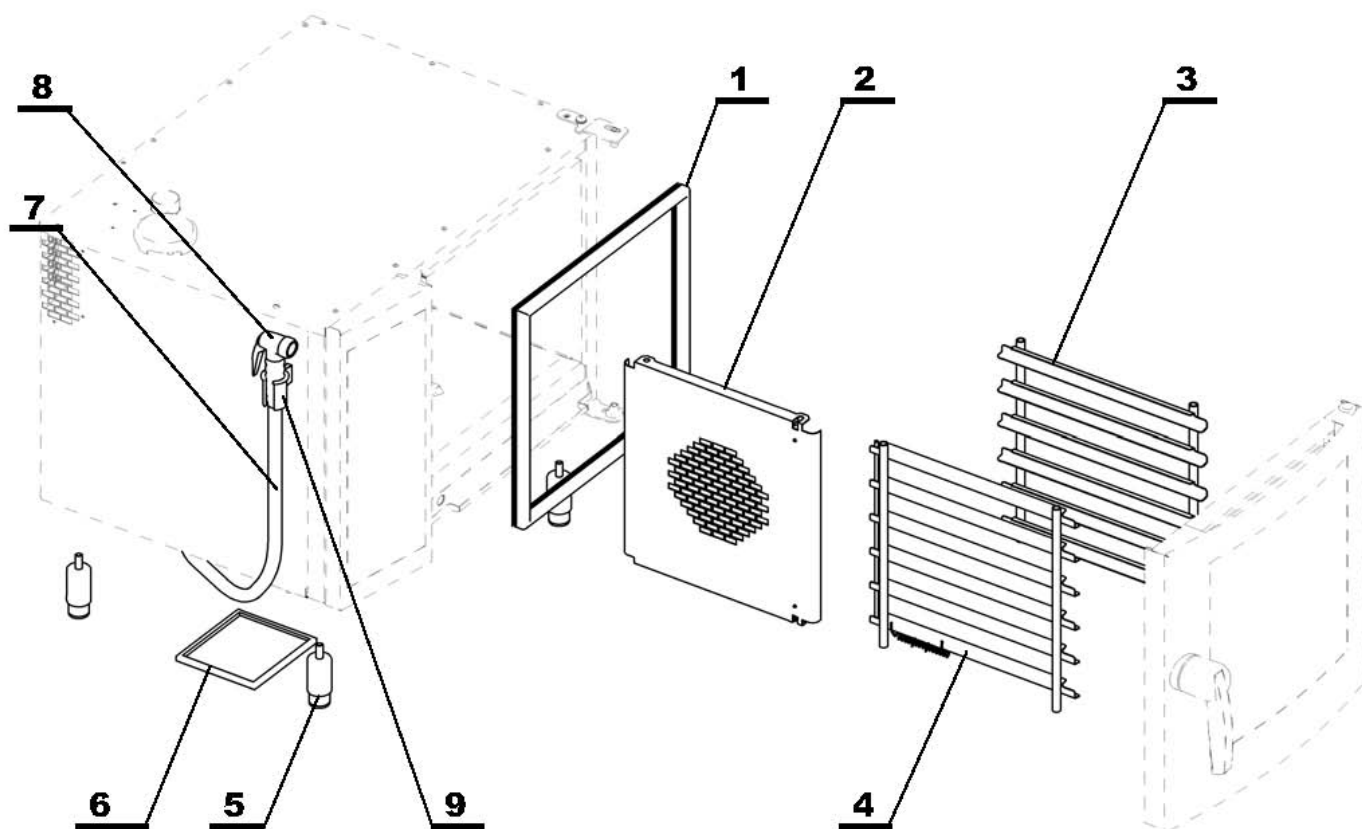

Item 圖號	Part N 料號	English name	中文品名	機 型	
				B623i	
1	AX00-0034	DOOR SEAL	門封條	●	
2	AC14-1400	INNER WALL	隔板	●	
3	AC19-1700	RACK RIGHT	右烤盤架	●	
4	AC18-1900	RACK LEFT	左烤盤架	●	
5	ZA15-0005	LEG	調整腳	●	
6	ZA17-0010	AIR FILTER VISION	濾網	●	
7	ZA11-0902	RUBBER HOSE FOR SHOWER 1.6m	水槍連接管 1.6 公尺	●	
8	ZA15-0100	HAND SHOWER	水槍	●	
9	AT00-0002	HAND SHOWER HOLDER	水槍架	●	