



FRESER INTERNATIONAL CORP.

老日光冷凍工業股份有限公司

FOOD AND BEVERAGE SOLUTIONS

retigo®  
*Vision*

**model**  
**B1011**

**萬能蒸烤箱**  
**零件分解圖**

COMBI OVEN  
SPARE PARTS

FRESER INTERNATIONAL

2011/09/01

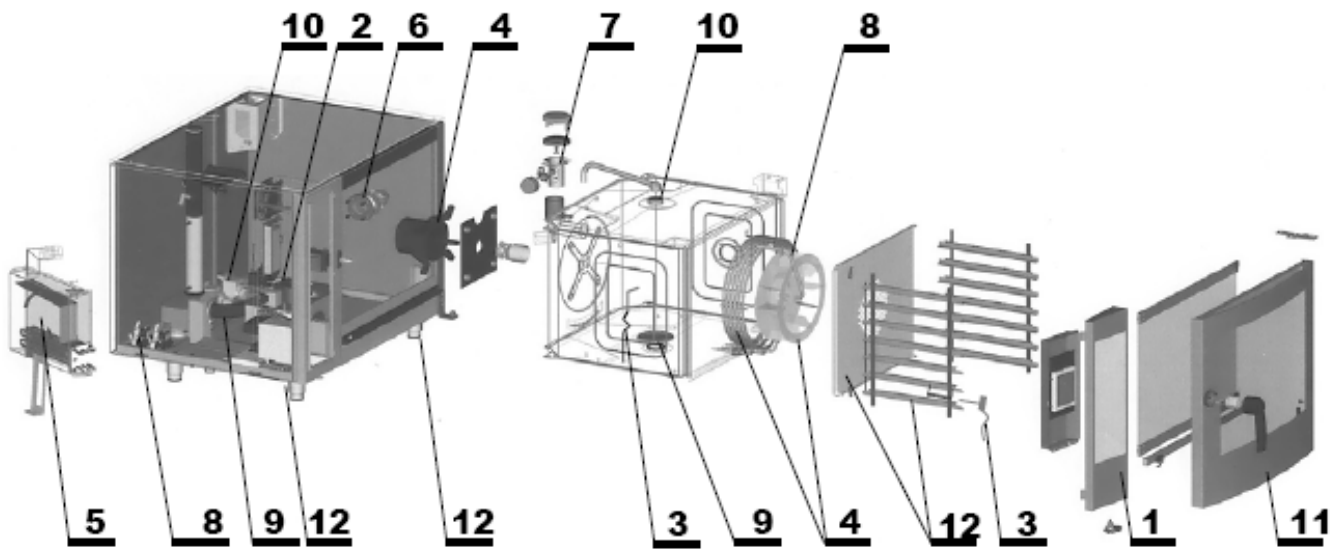

## 目錄 CATALOGUE

1.	控制板 CONTROL PANEL .....	P3
2.	電源板 POWER PANEL .....	P4
3.	溫度感應器 TEMPERATURE SENSOR .....	P5
4.	馬達、風扇、加熱器 MOTOR、VENTILATOR、HEATING ...	P6
5.	鍋爐 BOILER .....	P7
6.	照明燈 LIGHT .....	P8
7.	抽濕閥 FLAP VALVE .....	P9
8.	進水系統(噴霧型) WATER DISTRIBUTION SYSTEM (INJECTION) .....	P10
	進水系統(鍋爐型) WATER DISTRIBUTION SYSTEM (BOILER) .....	P11

9.	排水系統 DRAINAGE SYSTEM .....	P12
10.	自動清潔系統 AUTOMATIC CLEANING SYSTEM .....	P13
11.	門 DOOR .....	P14
12.	組件 ACCESSORIES .....	P15

## 1. 控制板 CONTROL PANEL

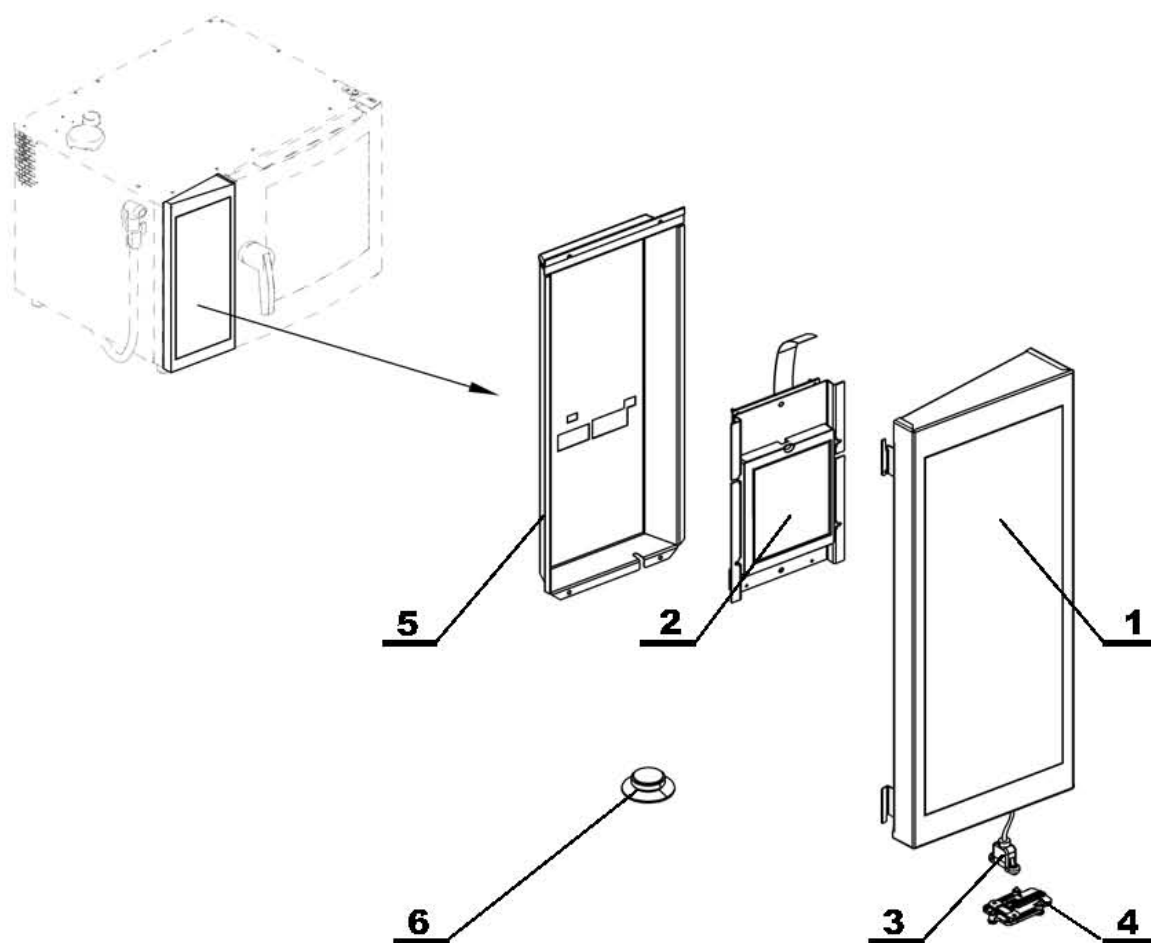

Item 圖 號	Part N 料 號	English name	中文品名	機 型	
				B1011i	B1011b
1	AC21-1305/S	LEFT CORNER PLATE 10 – BLUE WITH USB CONNECTOR	控制板框架 (含 USB 連接器)	●	●
1	AC21-1305	WHOLE LEFT CORNER WITH ELECTRONIC 10 – BLUE	控制板(含框架)	●	●
2	XC10-1800	ELECTRONIC BOARD SET VISION BLUE 2009	控制板	●	●
3	EA05-0052	USB CABLE	USB 連接線	●	●
4	SP21-0001	USB COVER	USB 外蓋	●	●
5	AP10-0017	CONTROL BOARD BACK WALL	控制板背板	●	●
6	EA13-0151	AUXILIARY LOUDSPEAKER	揚聲器	●	●

## 2. 電源板 POWER PANEL

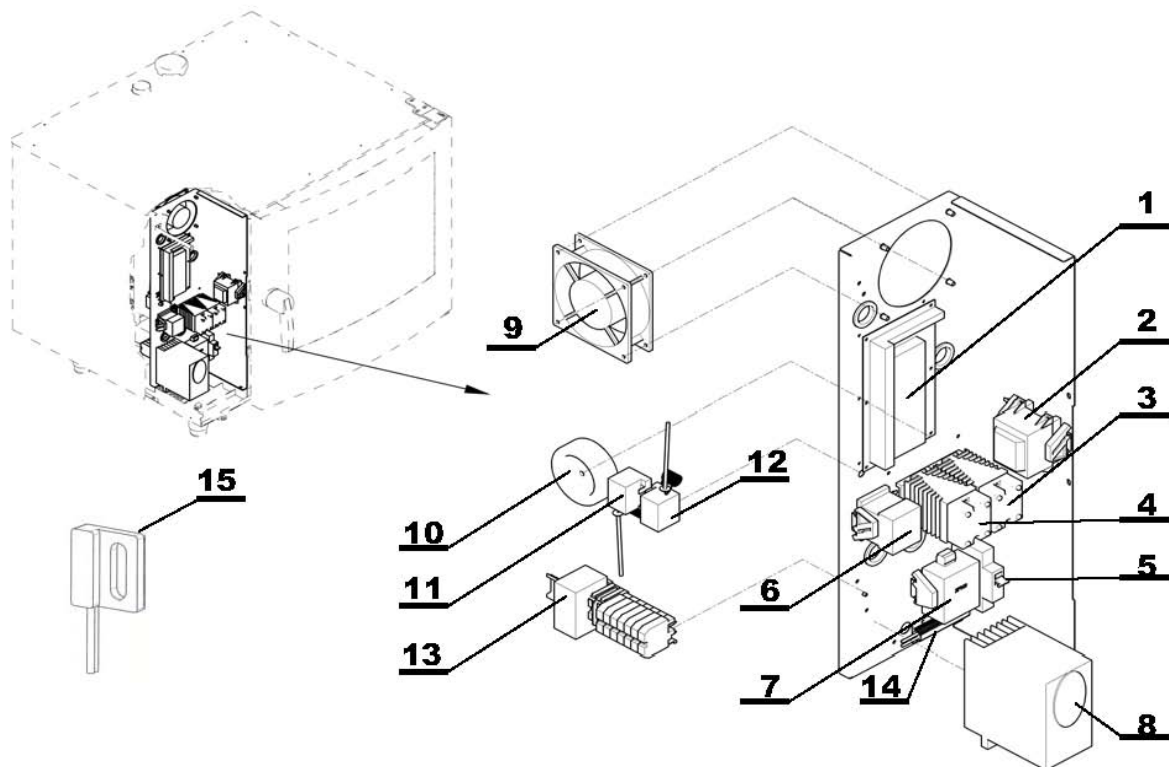

Item 圖 號	Part N 料 號	English name	中文品名	機 型	
				B1011i	B1011b
1	EA14-0060	POWER SUPPLY BOARD VISION RP20.B.15	電源板	●	●
2	EA13-0008	TRANSFORMER 17V	變壓器 17V	●	●
3	EA02-0203	SOLID STATE RELAY	固態繼電器		●
4	EA02-0203	SOLID STATE RELAY	固態繼電器	●	●
5	EA03-0016	CIRCUIT BREAKER	斷路開關	●	●
6	EA02-0004	CONTACTOR	電磁接觸器	●	●
7	EA13-0109	SUPPRESSOR		●	●
8	EA13-0400	FREQUENCY CONVERTER	頻率轉換器	●	●
9	ZA21-0007	FAN	風扇	●	●
10	EA13-0011	TRANSFORMER 230V/11.5V	變壓器 230V/11.5V	●	●
11	EA04-0011	THERM. FUSE FOR BOILER 140°C	鍋爐安全限溫器		●
12	EA04-0012	THERM. FUSE FOR SPACE 360°C	內箱安全限溫器	●	●
13	EA13-0057	SUPPRESSION COMPONENT		●	●
14	EA16-0041	RESISTOR		●	●
15	EA01-0015	DOOR SWITCH	門開關	●	●

### 3.溫度感應器 TEMPERATURE SENSOR

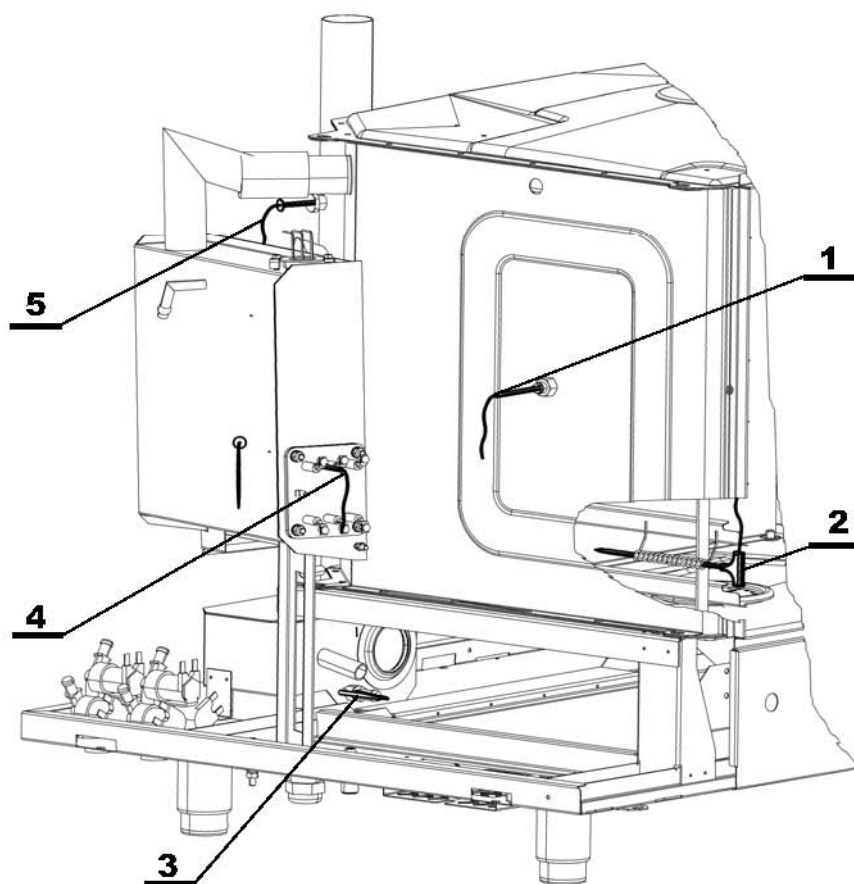

Item 圖 號	Part N 料 號	English name	中文品名	機 型	
				B1011i	B1011b
1	EA10-0103	SHEATED THERMOMETER VISION	內箱溫度感應器	●	●
2	EA10-0113	THERMOCOUPLE PROBE VISION	中心溫度探針	●	●
3	EA10-0104	THERMOCOUPLE CABLE VISION-FOR BOILER	鍋爐溫度感應器		●
4	EA10-0104	THERMOCOUPLE CABLE VISION-FOR BOILER	排水溫度感應器		●
5	EA10-0103	SHEATED THERMOMETER VISION	蒸汽溫度感應器		●

#### 4. 馬達、風扇、加熱器

# MOTOR 、 VENTILATOR 、 HEATING

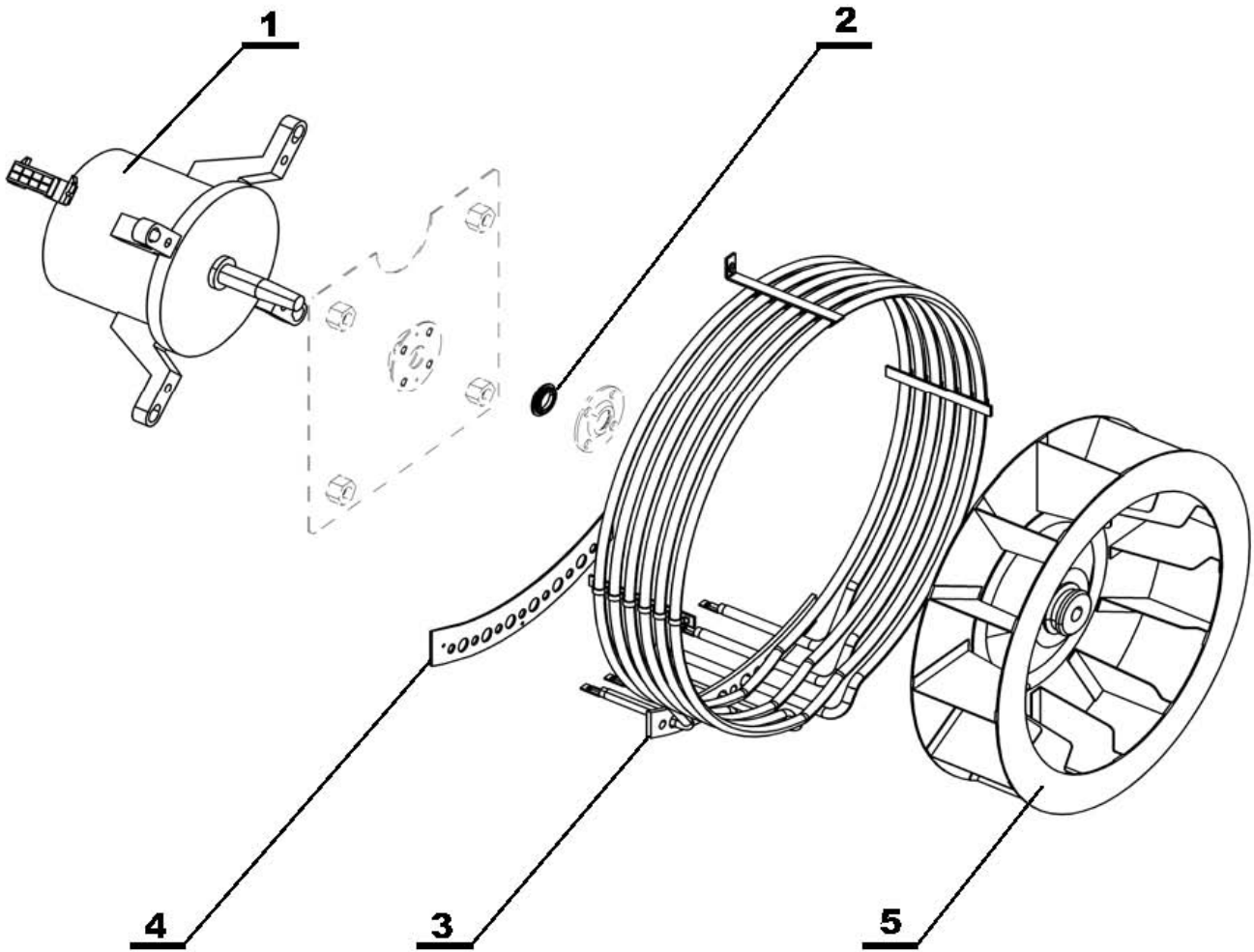

Item 圖 號	Part N 料 號	English name	中文品名	機 型	
				B1011i	B1011b
1	EA11-0013	ELECTROMOTOR	風扇馬達	●	●
2	AX00-0006	MOTOR SEAL	馬達軸封	●	●
3	EX00-0007	SPACE HEATING ELEMENT 16000 W	內箱加熱器	●	●
4	AX00-0008	SEAL	內箱加熱器墊片	●	●
5	AX09-0001	VENTILATOR FAN	風扇	●	●

## 5. 鍋爐 BOILER

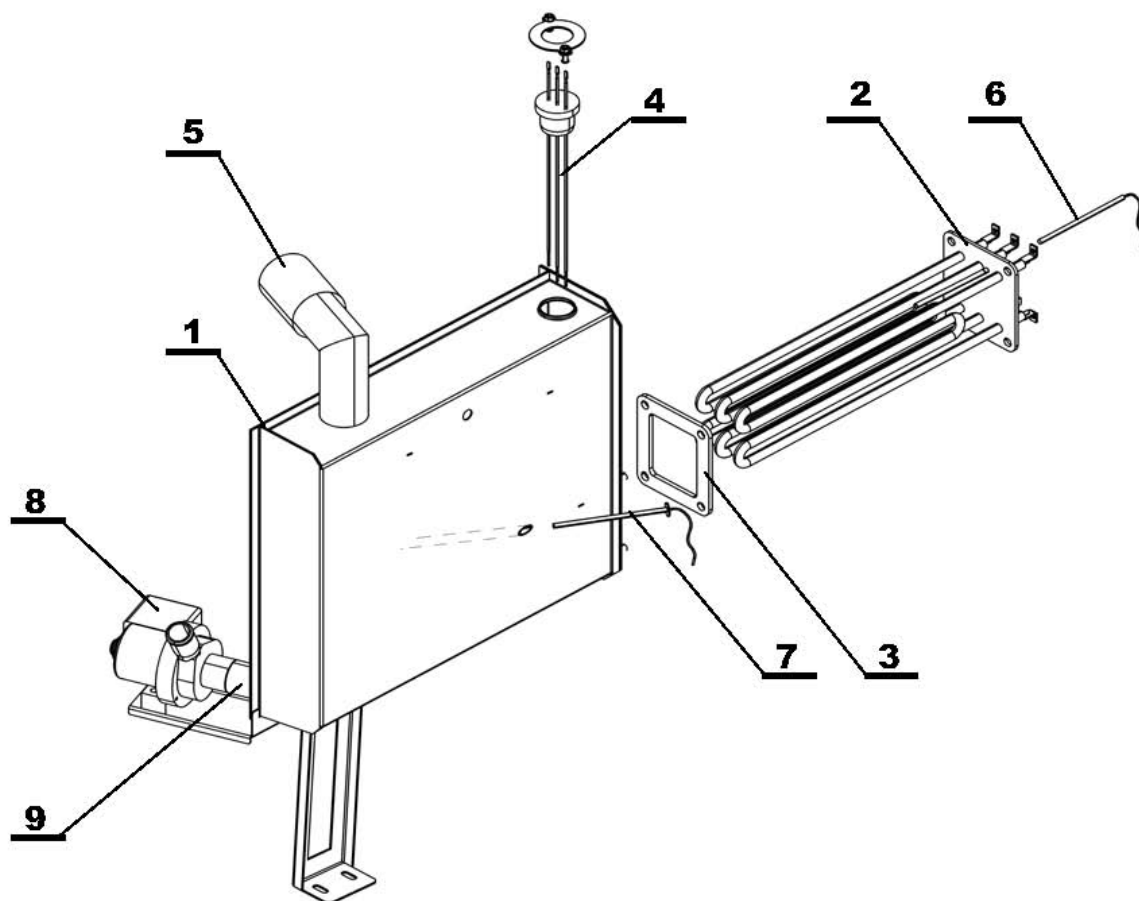

Item 圖號	Part N 料號	English name	中文品名	機 型	
				B1011i	B1011b
1	AC24-0700	BOILER	鍋爐		●
2	EX24-0008	BOILER HEATING ELEMENT 9KW	鍋爐加熱器 9KW		●
3	AX24-0002	BOILER HEATING ELEMENT SEAL	鍋爐加熱器墊圈		●
4	AC24-0602	SENSOR FOR WATER LEVEL	水位探針		●
5	ZA10-0500	SILICON TUBE CONNECTION	蒸汽出口連接管		●
6	EA10-0104	THERMOCOUPLE CABLE FOR BOILER	鍋爐溫度感應器		●
7	EA04-0011	THERMAL FUSE BOILER 140 °C	鍋爐安全限溫器		●
8	EA12-0001	PUMP	泵浦		●
9	AA00-0030	HOSE 70mm BLACK	鍋爐泵浦連接管		●

## 6. 照明燈 LIGHT



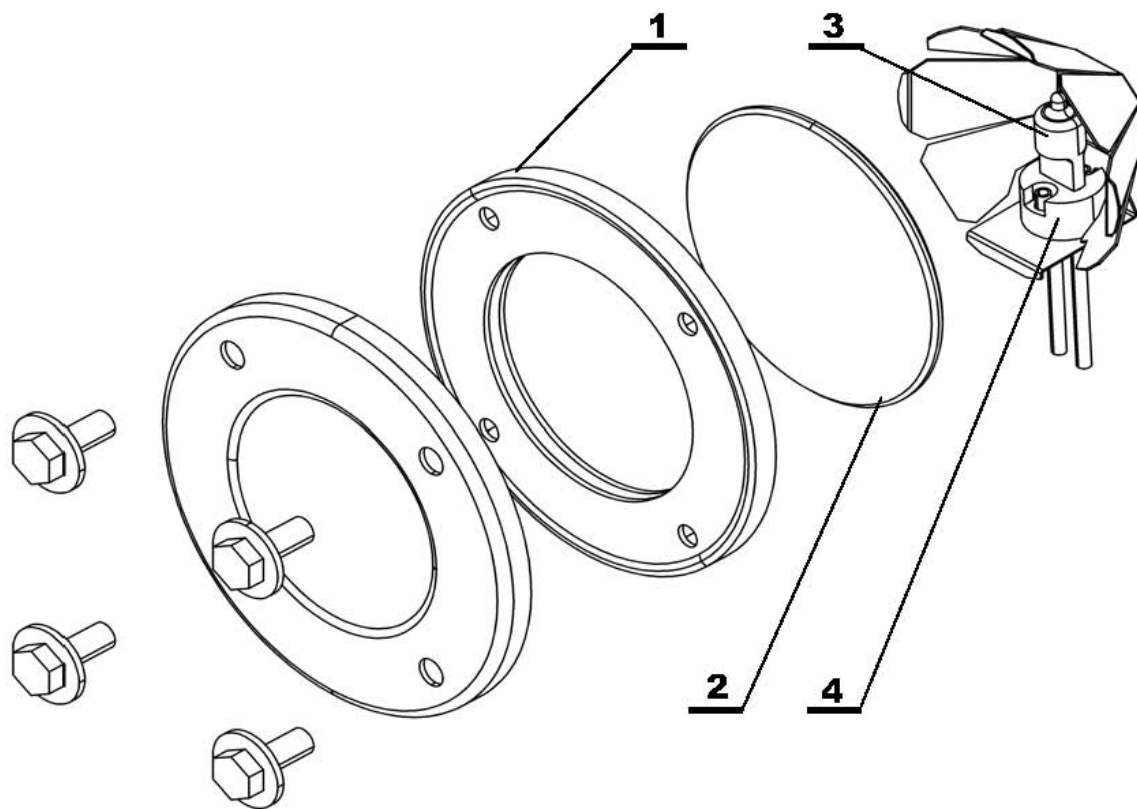

Item 圖 號	Part N 料 號	English name	中文品名	機 型	
				B1011i	B1011b
1	AX07-0005	LIGHT SEAL VISIOB	照明燈墊片	●	●
2	AX07-0004	GLASS PLATE	照明燈玻璃蓋	●	●
3	EX13-0100	HALOGEN LIGHT	照明燈	●	●
4	EX13-0101	HOLOGEN LIGHT BASE	照明燈座	●	●

## 7. 抽濕閥 FLAP VALVE

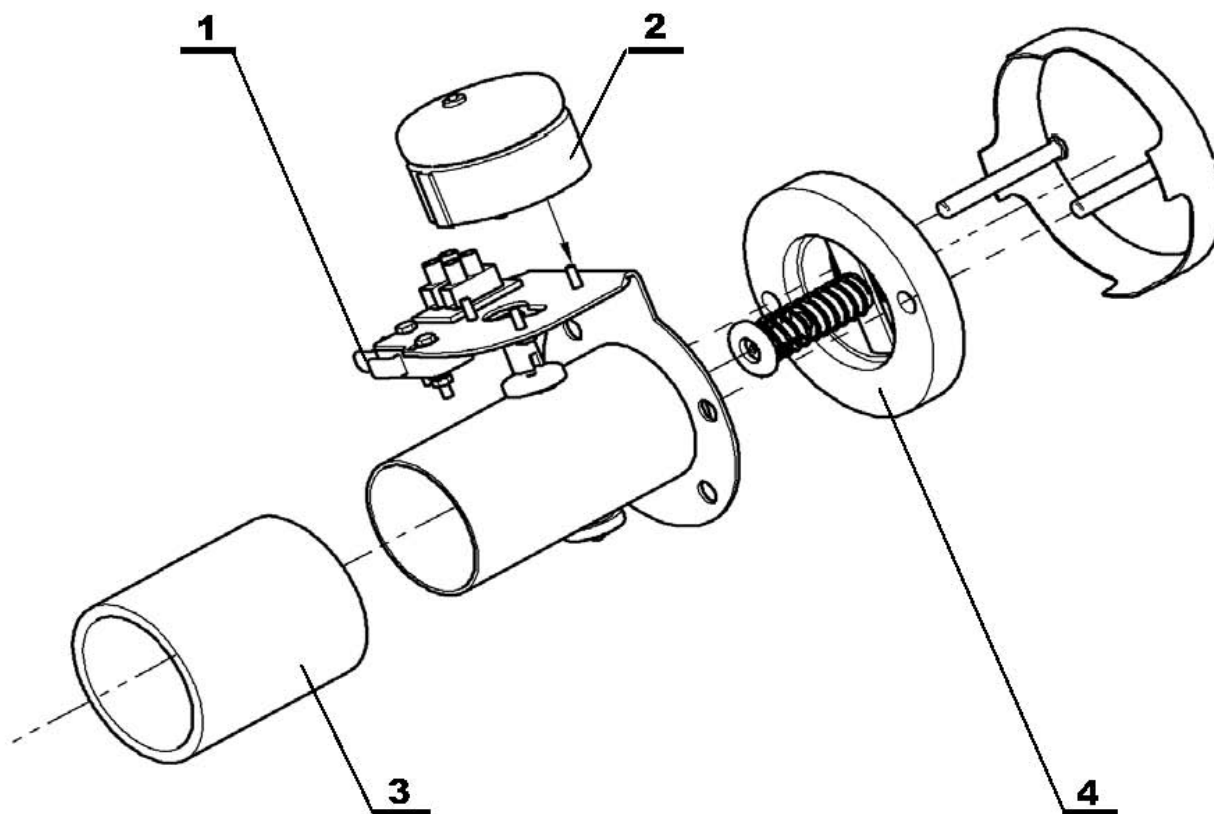

Item 圖 號	Part N 料 號	English name	中文品名	機 型	
				B1011i	B1011b
1	EA01-0052	MICROSWITCH	抽濕閥微動開關	●	●
2	EA11-0012	MOTOR	抽濕閥馬達	●	●
3	AT00-0006	FLAP VALVE HOSE	抽濕閥管	●	●
4	AC25-0105	PLUG	抽濕閥塞頭	●	●

## 8. 進水系統(噴霧型)

# WATER DISTRIBUTION SYSTEM (INJECTION)

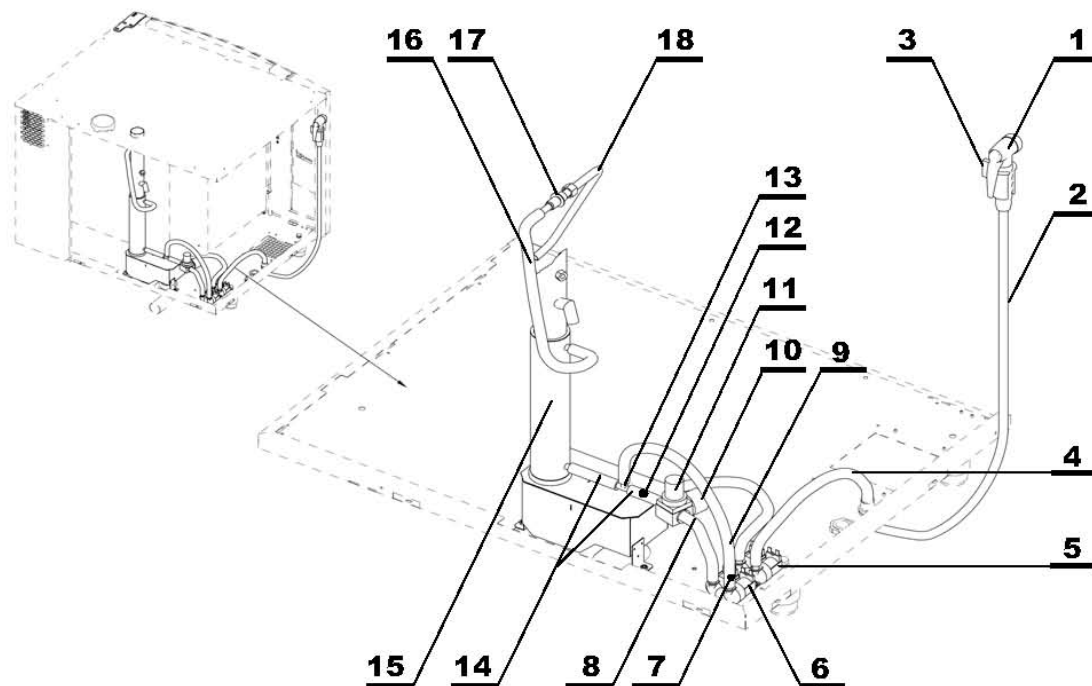

Item 圖號	Part N 料號	English name	中文品名	機 型	
				B1011i	B1011b
1	ZA15-0100	HAND SHOWER	水槍	●	
2	ZA11-0902	RUBBER HOSE FOR SHOWER 1.6m	水槍連接管 1.6 公尺	●	
3	AT00-0002	SHOWER HOWER	水槍固定架	●	
4	AA26-0100	HOSE 10 x 3.6 440	進水管	●	
5	EA12-0050	DOUBLE SOLENOID VALVE	雙線圈進水電磁閥	●	
6	EA12-0056	TRIPLE SOLENOID VALVE	三線圈進水電磁閥	●	
7	EA12-0303	REDUCTION NOZZLE	噴嘴	●	
8	AA26-0104	HOSE 10 x 3.6 90	進水管	●	
9	AA26-0100	HOSE 10 x 3.6 440	進水管	●	
10	ZA12-0401	MANOMETER	壓力錶	●	
11	ZA12-0201	WATER REDUCING VALVE	水壓調節閥	●	
12	AT00-0056	NOZZLE 07	噴嘴	●	
13	ZA10-0553	T-FITTING 10mm	三通 10mm	●	
14	AA26-0104	HOSE 10 x 3.6 90	進水管	●	
15	AC05-2100	CHIMNEY	排煙管	●	
16	AA26-0100	HOSE 10 x 3.6 440	進水管	●	
17	AC00-2500	BUSHING	襯套	●	
18	AC12-0700	INJECTINN PIPE	噴霧管	●	

## 進水系統(鍋爐型)

# WATER DISTRIBUTION SYSTEM (BOILER)

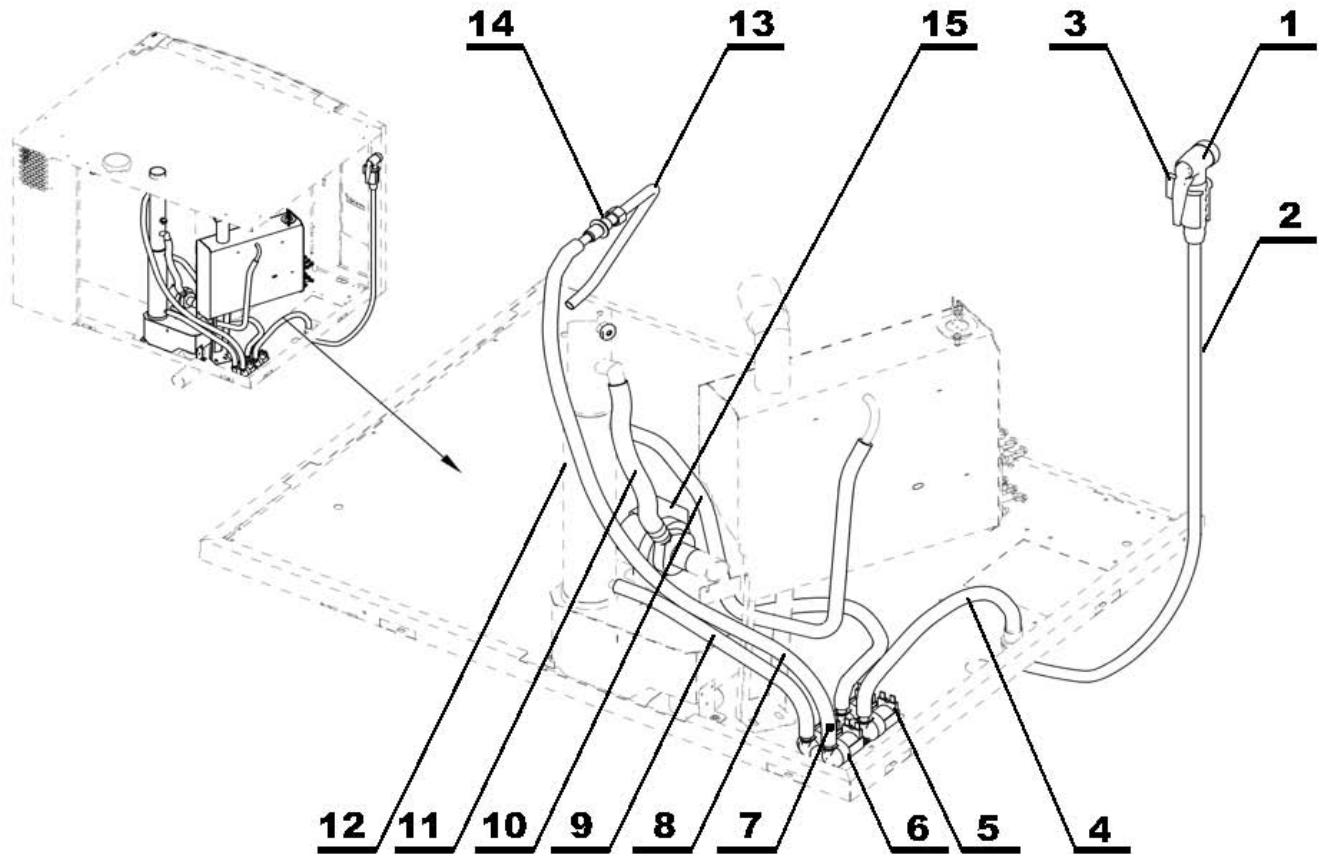

Item 圖號	Part N 料號	English name	中文品名	機 型	
				B1011i	B1011b
1	ZA15-0100	HAND SHOWER	水槍		●
2	ZA11-0902	RUBBER HOSE FOR SHOWER 1.6m	水槍連接管 1.6 公尺		●
3	AT00-0002	SHOWER HOWER	水槍固定架		●
4	AA26-0100	HOSE 10 x 3.6 440	進水管		●
5	EA12-0050	DOUBLE SOLENOID VALVE	雙線圈進水電磁閥		●
6	EA12-0056	TRIPLE SOLENOID VALVE	三線圈進水電磁閥		●
7	EA12-0303	REDUCTION NOZZLE	噴嘴		●
8	AA26-0101	HOSE 10 x 3.6 350	進水管		●
9	AT32-0015	HOSE 10 x 3.6 840	進水管		●
10	AA26-0106	HOSE 10 x 3.6 770	進水管		●
11	AA26-0150	HOSE 16/22 230	進水管		●
12	AC05-1700	CHIMNEY	排煙管		●
13	ZA12-0700	INJECTION PIPE	噴霧管		●
14	AC00-2500	BUSHING	襯套		●
15	EA12-0001	PUMP	泵浦		●

## 9. 排水系統 DRAINAGE SYSTEM

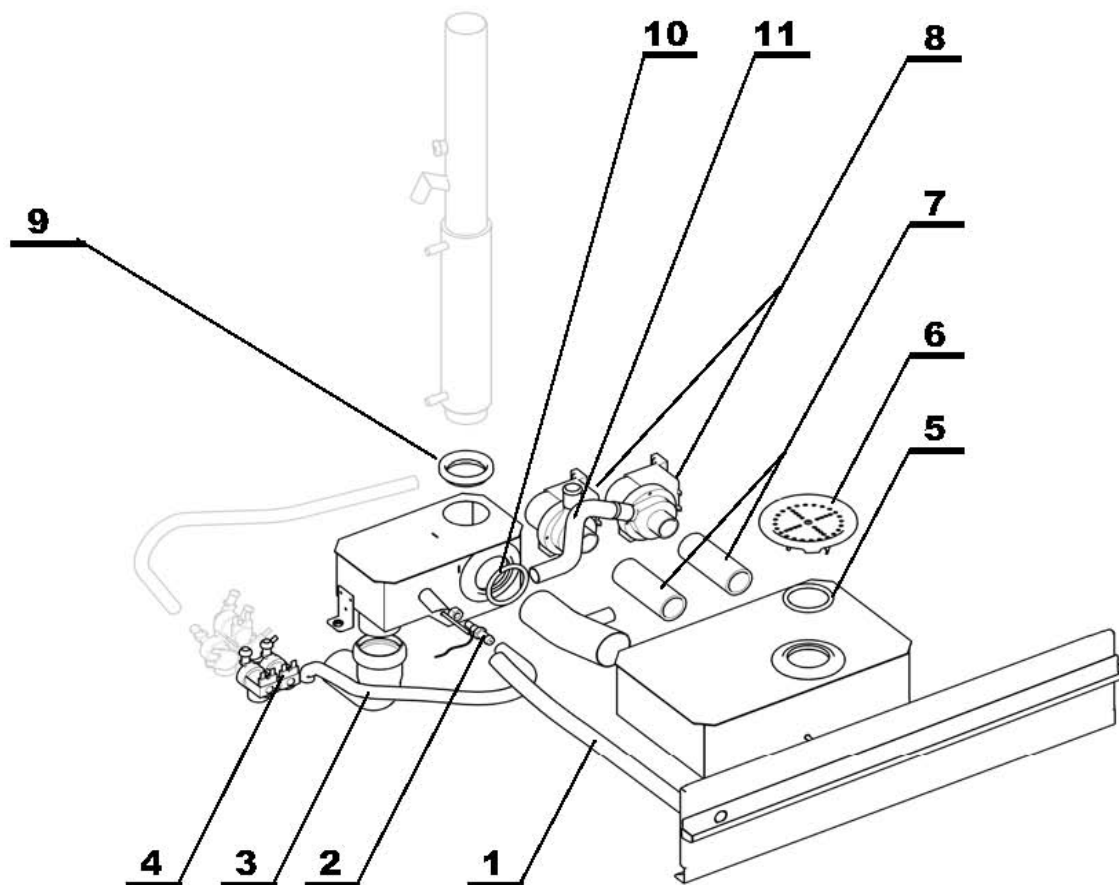

Item 圖 號	Part N 料 號	English name	中文品名	機 型	
				B1011i	B1011b
1	AA26-0154	HOSE 16/22 600	滴水槽排水管	●	●
2	AT01-0013	NOZZLE	噴嘴	●	●
3	AA26-0100	HOSE 10 x 3.6 440	進水管	●	●
4	EA12-0050	DOUBLE SOLENOID VALVE	雙線圈進水電磁閥	●	●
5	ZA13-1549	O-RING	O 型環	●	●
6	AC02-2202	DRAIN CAP	排水蓋	●	●
7	AA00-0030	HOSE 70mm BLACK	排水管	●	●
8	EA12-0001	PUMP	泵浦	●	●
9	AX04-0002	SEAL D5	墊圈	●	●
10	ZA13-1549	O-RING	O 型環	●	●
11	AA26-0153	HOSE16/22 200	排水管	●	●

# 10.自動清潔系統 AUTOMATIC CLEANING SYSTEM

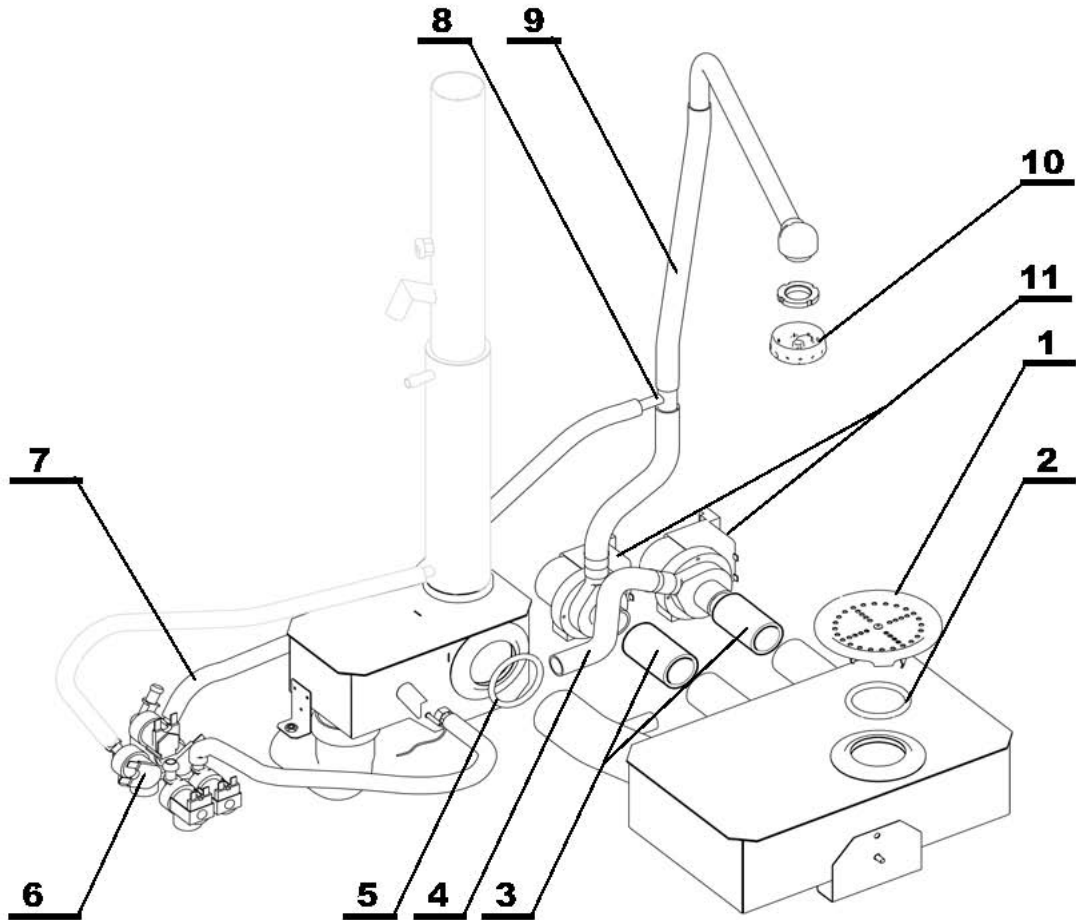

Item 圖 號	Part N 料 號	English name	中文品名	機 型	
				B1011i	B1011b
1	AC02-2202	DRAIN CAP	排水蓋	●	●
2	ZA13-1549	O-RING	O 型環	●	●
3	AA00-0030	HOSE 70mm BLACK	排水管 7 公分(黑)	●	●
4	AA26-0153	HOSE16/22 200	排水管	●	●
5	ZA13-1549	O-RING	O 型環	●	●
6	EA12-0056	TRIPLE SOLENOID VALVE	三線圈進水電磁閥	●	●
7	AA26-0102	HOSE 10 x 3.6 770	進水管	●	●
8	AC32-0400	T- FITTING	三通	●	●
9	AA26-0152	HOSE16/22 360	排水管	●	●
10	AAX32-0001	CLEANING NOZZLE	清洗噴頭	●	●
11	EA12-0001	PUMP	泵浦	●	●

# 11. 門 DOOR

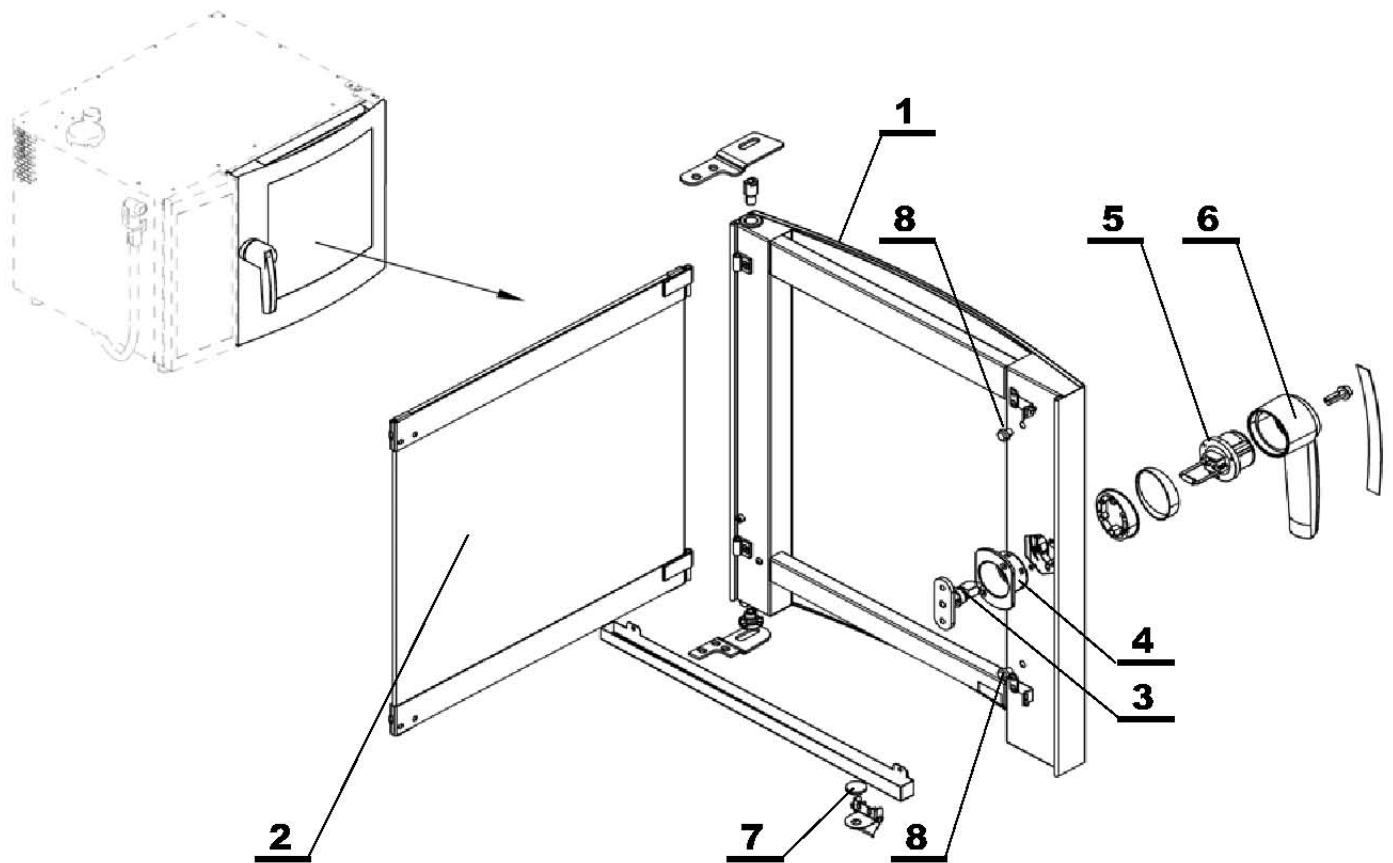

Item 圖號	Part N 料號	English name	中文品名	機 型	
				B1011i	B1011b
1	AC03-3200	DOOR 10 07 VISION COMPLETE	玻璃門組	●	●
2	AC03-3201	INTERIOR GLASS10 07 VISION	內玻璃	●	●
3	ZA20-0902	BILL KL-J	門勾	●	●
4	AX08-0020	BOX	門鎖匣	●	●
5	ZA20-0901	DOOR MECHANISM	門鎖	●	●
6	AX08-0021	HANDLE VISION	門把手	●	●
7	ZA13-0516	STOPPER	門擋片	●	●
8	AX03-0076	WINDOWS STOP	內玻璃擋片	●	●

## 12. 組件 ACCESSORIES

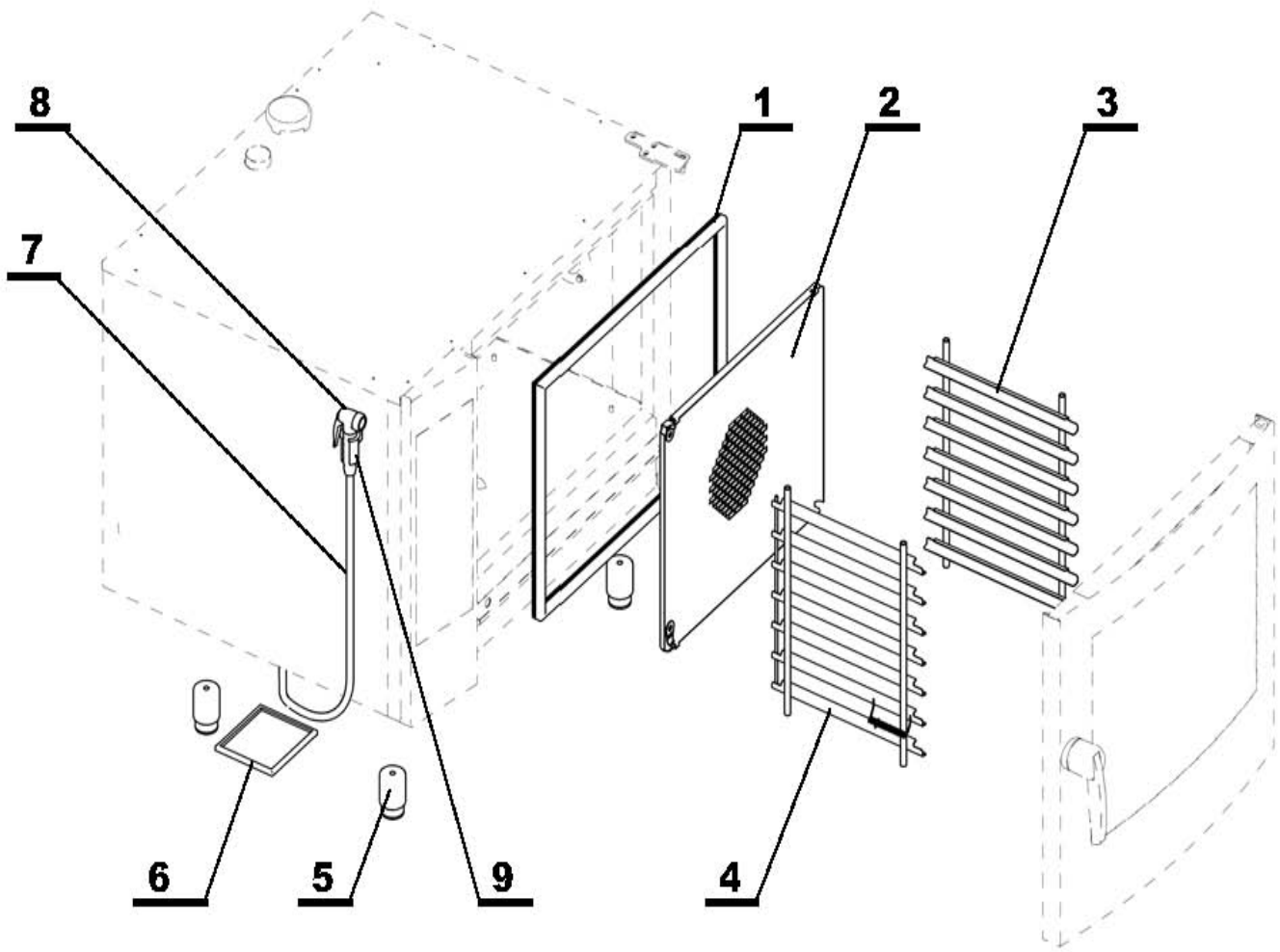

Item 圖號	Part N 料號	English name	中文品名	機 型	
				B1011i	B1011b
1	AX00-0036	DOOR SEAL	門封條	●	●
2	AC14-1200	INNER WALL	隔板	●	●
3	AC19-1600	RACK RIGHT	右烤盤架	●	●
4	AC18-1800	RACK LEFT	左烤盤架	●	●
5	ZA15-0002	LEG	調整腳	●	●
6	ZA17-0010	AIR FILTER VISION	濾網	●	●
7	ZA11-0902	RUBBER HOSE FOR SHOWER 1.6m	水槍連接管 1.6 公尺	●	●
8	ZA15-0100	HAND SHOWER	水槍	●	●
9	AT00-0002	HAND SHOWER HOLDER	水槍架	●	●