

Ice-O-Matic[®]

SERVICE PARTS MANUAL

MODEL-ICE1405, ICE1406 and ICE1407 Version 3

Includes 50Hz.and 3 phase Units



Ice-O-Matic
11100 East 45th Ave
Denver, Colorado 80239
14-1026

Date 10/2/15

ICE1400 Series Version 3 Service Parts

This parts list contains the service parts available for the ICE1400 Series Version 3 icemakers.

Check the model number on the data plate and refer to the correct listing for the specific component.

Check carefully that the correct part is identified and ordered.

Table of Contents	Page 1
Exterior Panels	Page 2
Air Cooled	Page 4
Water Cooled	Page 6
Remote	Page 8
Control Box	Page 10
Harvest Assist	Page 12
Water Pump/Float	Page 14
VRC Condenser	Page 16

**Ice-O-Matic
11100 East 45th Ave.
Denver Co. 80239
800-423-3367**

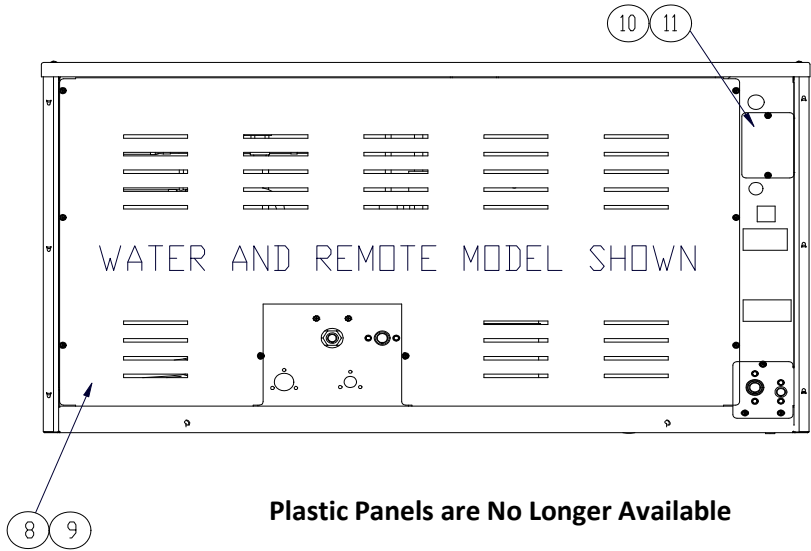

Plastic Panels are No Longer Available

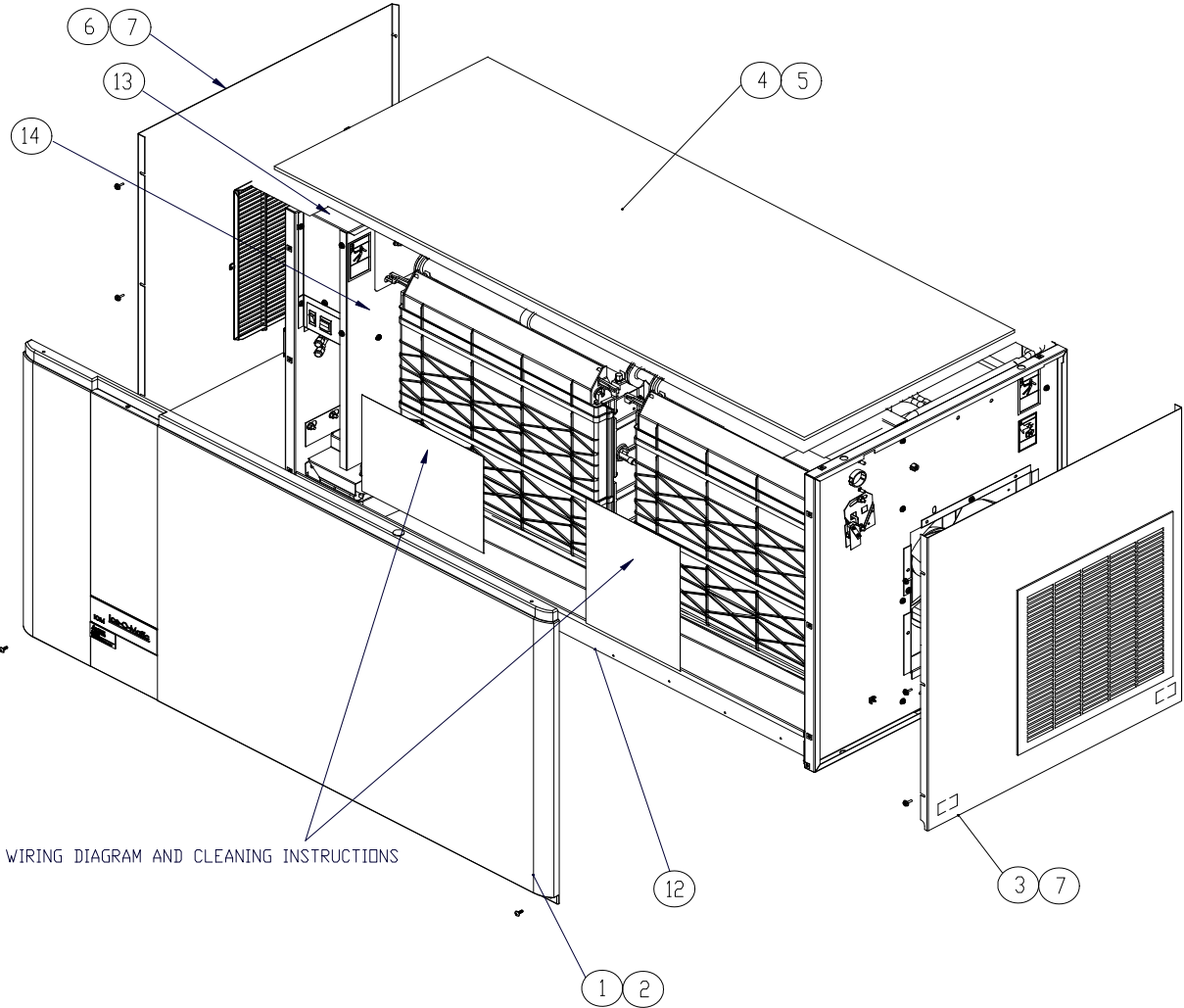

Item No.	Model Number			Description
	ICE1406	ICE1405	ICE1407	
1	2031465-05S	2031465-05S	2031465-05S	Front Panel NLA
2	9031098-02	9031098-02	9031098-02	Front Panel Screws
3	2031508-01S	2031508-01S	2031508-01S	Right Hand Side Panel- Air Cooled Only NLA
	3021929-01	3021929-01	3021929-01	Right Hand Side Panel-Water Cooled and Remote Only NLA
4	9051469-01	9051469-01	9051469-01	Top Panel NLA
5	9031098-02	9031098-02	9031098-02	Top Panel Screws
6	2031509-01S	2031509-01S	2031509-01S	Left Hand Side Panel- Air Cooled Only NLA
	3021934-01	3021934-01	3021934-01	Left Hand Side Panel-Water Cooled and Remote Only NLA
7	9031046-03	9031046-03	9031046-03	Side Panel Screw
8	3021926-01	3021926-01	3021926-01	Rear Panel
9	9031046-01	9031046-01	9031046-01	Rear Cover Panel Screws
10	3013308-01	3013308-01	3013308-01	Junction Box Cover
11	9031046-01	9031046-01	9031046-01	Junction Box Cover Screws
12	3013315-01	3013315-01	3013315-01	Ice Deflector
13	3013294-01	3013294-01	3013294-01	Control Box Top Cover
14	3013293-01	3013293-01	3013293-01	Control Box Side Cover
15	N/A	3012931-02	N/A	Machine Compartment Cover

Plastic Panels are No Longer Available - NLA = No Longer Available

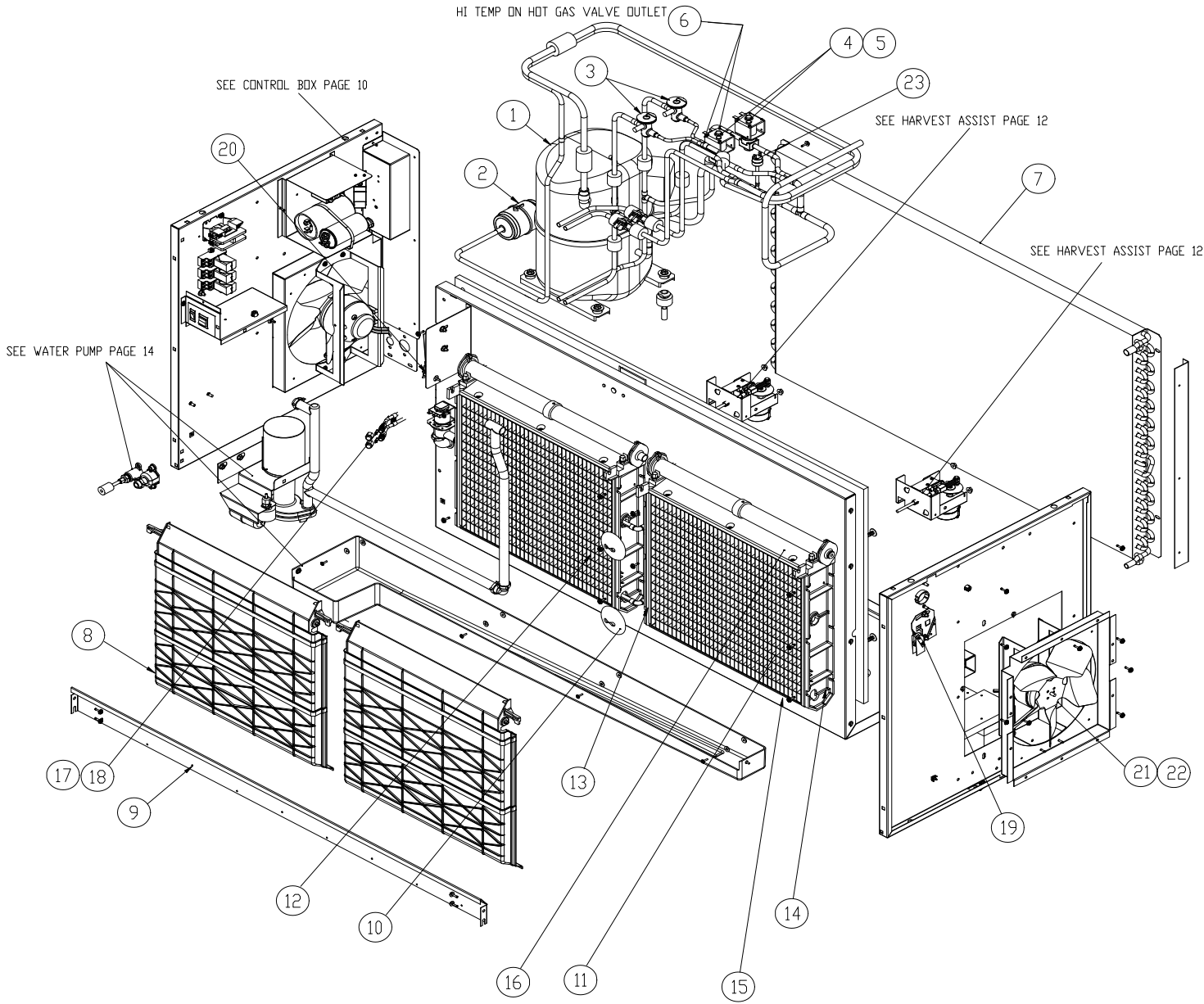

Item No.	Model Number			Description
	ICE1406A3	ICE1405A3	ICE1407A3	
1	9181142-11	9181143-12	9181111-12	Compressor*
2	9151163-02	9151163-02	9151163-02	Filter Drier (9151004-03 is NLA)
3	9151150-101	9151150-101	9151150-101	Expansion Valve (Includes Valve, Insulation and Bulb Clamp)
4	9151123-02	9151123-02	9151123-02	Hot Gas Valve Body
5	9151123-04	9151123-04	9151123-04	Hot Gas Valve Coil
6	9041098-01	9041098-01	9041098-01	High Temperature Safety Control
7	9141132-01	9141132-01	9141132-01	Air Condenser
8	9051154-14	9051154-14	9051154-14	Evaporator Splash Curtain
9	3013315-01	3013315-01	3013315-01	Ice Deflector
10	9051237-02	9051237-02	9051237-02	Washer Tube
11	2051237-81	2051237-81	2051237-81	Evaporator Right Side Full Cube
11	2051237-82	2051237-82	2051237-82	Evaporator Right Side Half Cube
12	2051238-81	2051238-81	2051238-81	Evapoartor Left Side Full Cube
12	2051238-82	2051238-82	2051238-82	Evapoartor Left Side Half Cube
13	9051540-03	9051540-03	9051540-03	Evaporator Left Side Mounting Panel
14	9051540-04	9051540-04	9051540-04	Evaporator Right Side Mounting Panel
15	9051135-04	9051135-04	9051135-04	Water Return
16	9051135-05	9051135-05	9051135-05	Spillway
17	9091086-02	9091086-02	9091086-02	Valve Core
18	9091086-03	9091086-03	9091086-03	Valve Cap
19	9101124-02	9101124-02	9101124-02	Bin Switch Right Side (Cut Arm)
20	9101124-02	9101124-02	9101124-02	Bin Switch Left Side (Cut Arm)
21	9161078-03	9161078-02	9161078-03	Fan Motor
22	9131383-01	9131383-01	9131383-01	Fan Blade
23	9041096-01	9041096-01	9041096-01	Fan Control

*Note ICE1406 Air Cooled Compressor 9181111-11 is NLA. Replaced by 9181142-11

*Note ICE1405 Air Cooled Compressor 9181094-12 is NLA. Replaced by 9181143-12

Reference Page 11 for Compressor Starting Components

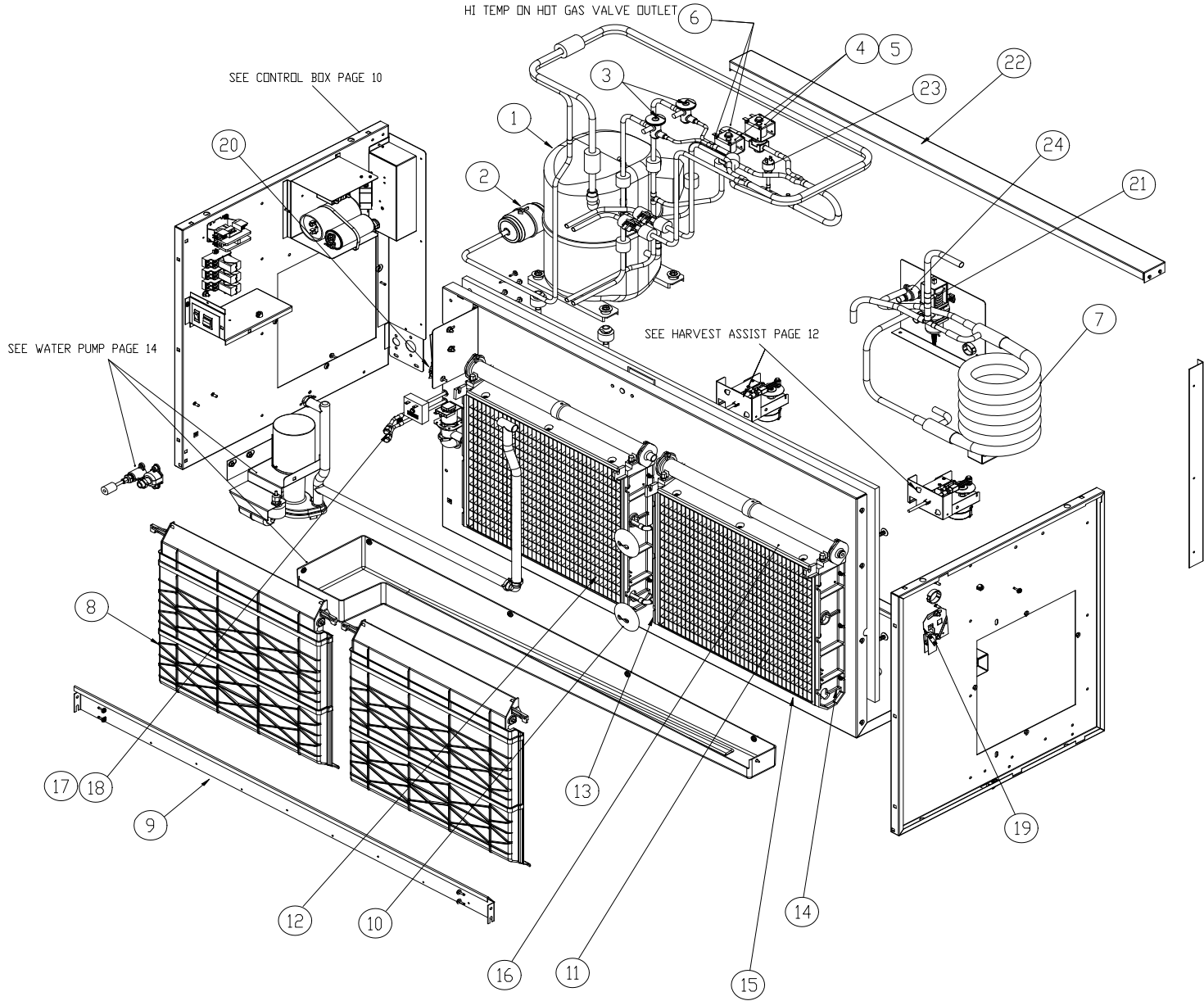

Item No.	Model Number			Description
	ICE1406W3	ICE1405W3	ICE1407W3	
1	9181142-11	9181143-12	9181111-12	Compressor*
2	9151163-02	9151163-02	9151163-02	Filter Drier (9151004-03 is NLA)
3	9151150-101	9151150-101	9151150-101	Expansion Valve (Includes Valve, Insulation and Bulb Clamp)
4	9151123-02	9151123-02	9151123-02	Hot Gas Valve Body
5	9151123-04	9151123-04	9151123-04	Hot Gas Valve Coil
6	9041098-01	9041098-01	9041098-01	High Temperature Safety Control
7	9141061-02	9141061-02	9141061-02	Water Condenser
8	9051154-14	9051154-14	9051154-14	Evaporator Splash Curtain
9	3013315-01	3013315-01	3013315-01	Ice Deflector
10	9051237-02	9051237-02	9051237-02	Washer Tube
11	2051237-81	2051237-81	2051237-81	Evaporator Right Side Full Cube
11	2051237-82	2051237-82	2051237-82	Evaporator Right Side Half Cube
12	2051238-81	2051238-81	2051238-81	Evapoartor Left Side Full Cube
12	2051238-82	2051238-82	2051238-82	Evapoartor Left Side Half Cube
13	9051540-03	9051540-03	9051540-03	Evaporator Left Side Mounting Panel
14	9051540-04	9051540-04	9051540-04	Evaporator Right Side Mounting Panel
15	9051135-04	9051135-04	9051135-04	Water return
16	9051135-05	9051135-05	9051135-05	Spillway
17	9091086-02	9091086-02	9091086-02	Valve Core
18	9091086-03	9091086-03	9091086-03	Valve Cap
19	9101124-02	9101124-02	9101124-02	Bin Switch Right Side (Cut Arm)
20	9101124-02	9101124-02	9101124-02	Bin Switch Left Side (Cut Arm)
21	9041059-01	9041059-01	9041059-01	Water Regulating Valve
22	3013316-01	3013316-01	3013316-01	Rear Brace
23	9041091-01	9041091-01	9041091-01	High Pressure Control
24	9091063-02	9091063-02	9091063-02	Condenser Drain Fitting

*Note ICE1406 Water Cooled Compressor 9181111-11 is NLA. Replaced by 9181142-11

*Note ICE1405 Water Cooled Compressor 9181094-12 is NLA. Replaced by 9181143-12

Reference Page 11 for Compressor Starting Components

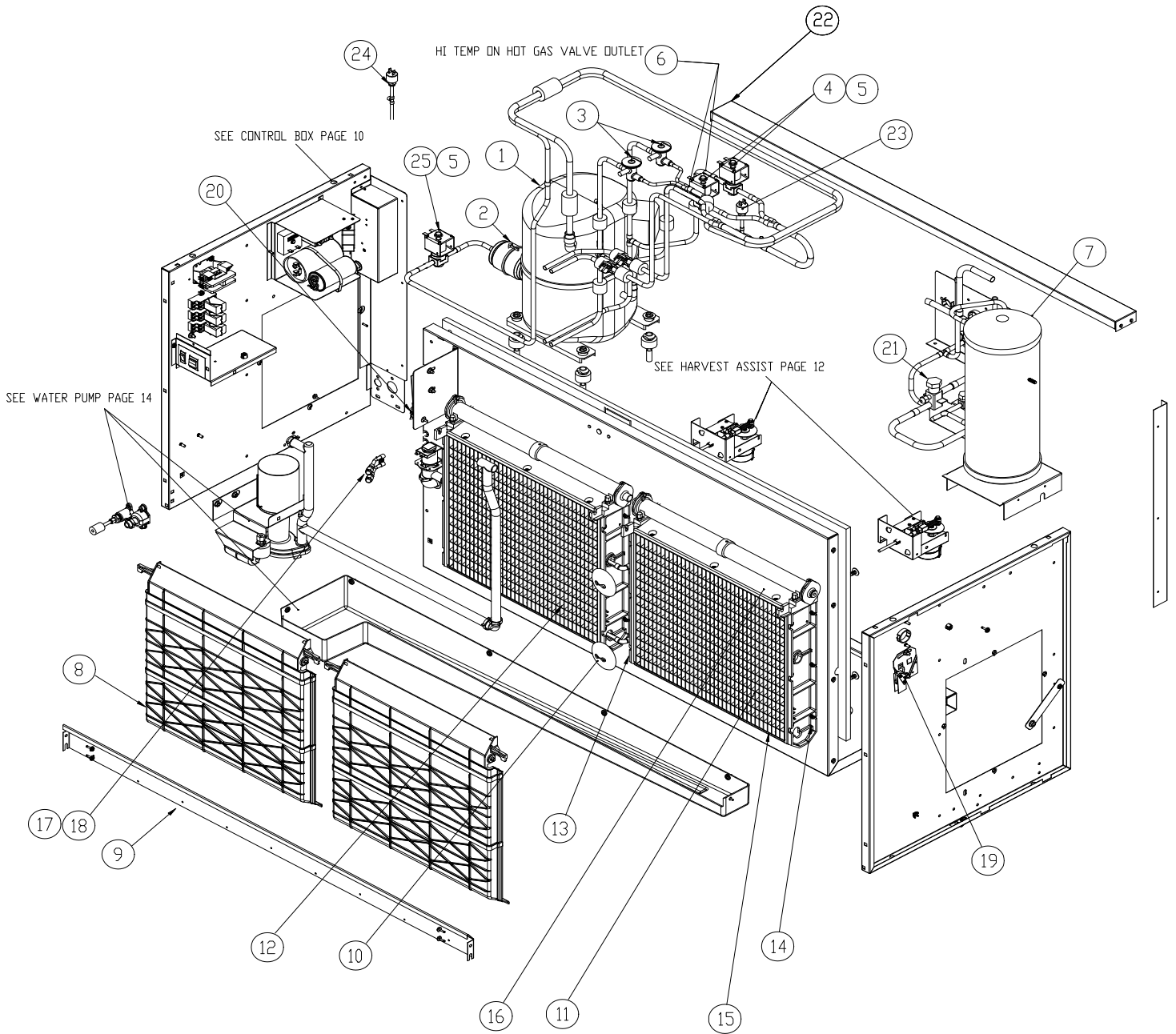

Item No.	Model Number			Description
	ICE1406R3	ICE1405R3	ICE1407R3	
1	9181142-11	9181143-12	9181111-12	Compressor*
2	9151163-02	9151163-02	9151163-02	Filter Drier (9151004-03 is NLA)
3	9151150-101	9151150-101	9151150-101	Expansion Valve (Includes Valve, Insulation and Bulb Clamp)
4	9151123-02	9151123-02	9151123-02	Hot Gas Valve Body
5	9151123-04	9151123-04	9151123-04	Hot Gas Valve Coil
6	9041098-01	9041098-01	9041098-01	High Temperature Safety Control
7	9151060-01	9151060-01	9151060-01	Receiver
8	9051154-14	9051154-14	9051154-14	Evaporator Splash Curtain
9	3013315-01	3013315-01	3013315-01	Ice Deflector
10	9051237-02	9051237-02	9051237-02	Washer Tube
11	2051237-81	2051237-81	2051237-81	Evaporator Right Side Full Cube
11	2051237-82	2051237-82	2051237-82	Evaporator Right Side Half Cube
12	2051238-81	2051238-81	2051238-81	Evapoartor Left Side Full Cube
12	2051238-82	2051238-82	2051238-82	Evapoartor Left Side Half Cube
13	9051540-03	9051540-03	9051540-03	Evaporator Left Side Mounting Panel
14	9051540-04	9051540-04	9051540-04	Evaporator Right Side Mounting Panel
15	9051135-04	9051135-04	9051135-04	Water Return
16	9051135-05	9051135-05	9051135-05	Spillway
17	9091086-02	9091086-02	9091086-02	Valve Core
18	9091086-03	9091086-03	9091086-03	Valve Cap
19	9101124-02	9101124-02	9101124-02	Bin Switch Right Side (Cut Arm)
20	9101124-02	9101124-02	9101124-02	Bin Switch Left Side (Cut Arm)
21	9091143-02	9091143-02	9091143-02	Remote Shut-Off Valve (Large)
	9091143-01	9091143-01	9091143-01	Remote Shut-Off Valve (Small)
22	3013316-01	3013316-01	3013316-01	Rear Brace
23	9041091-01	9041091-01	9041091-01	High Pressure Control
24	9041092-02	9041092-02	9041092-02	Pump Down Control
25	9151123-02	9151123-02	9151123-02	Liquid Line Solenoid
	9091001-12	9091001-12	9091001-12	1/2 Inch Coupling (Not Shown)
	9091001-11	9091001-11	9091001-11	3/8 Inch Coupling (Not Shown)
	9151139-01	9151139-01	9151139-01	Check Valve (Not Shown)

*Note ICE1406 Remote Cooled Compressor [9181111-11](#) is NLA. Replaced by [9181142-11](#)

*Note ICE1405 Remote Cooled Compressor [9181094-12](#) is NLA. Replaced by [9181143-12](#)

Reference Page 11 for Compressor Starting Components

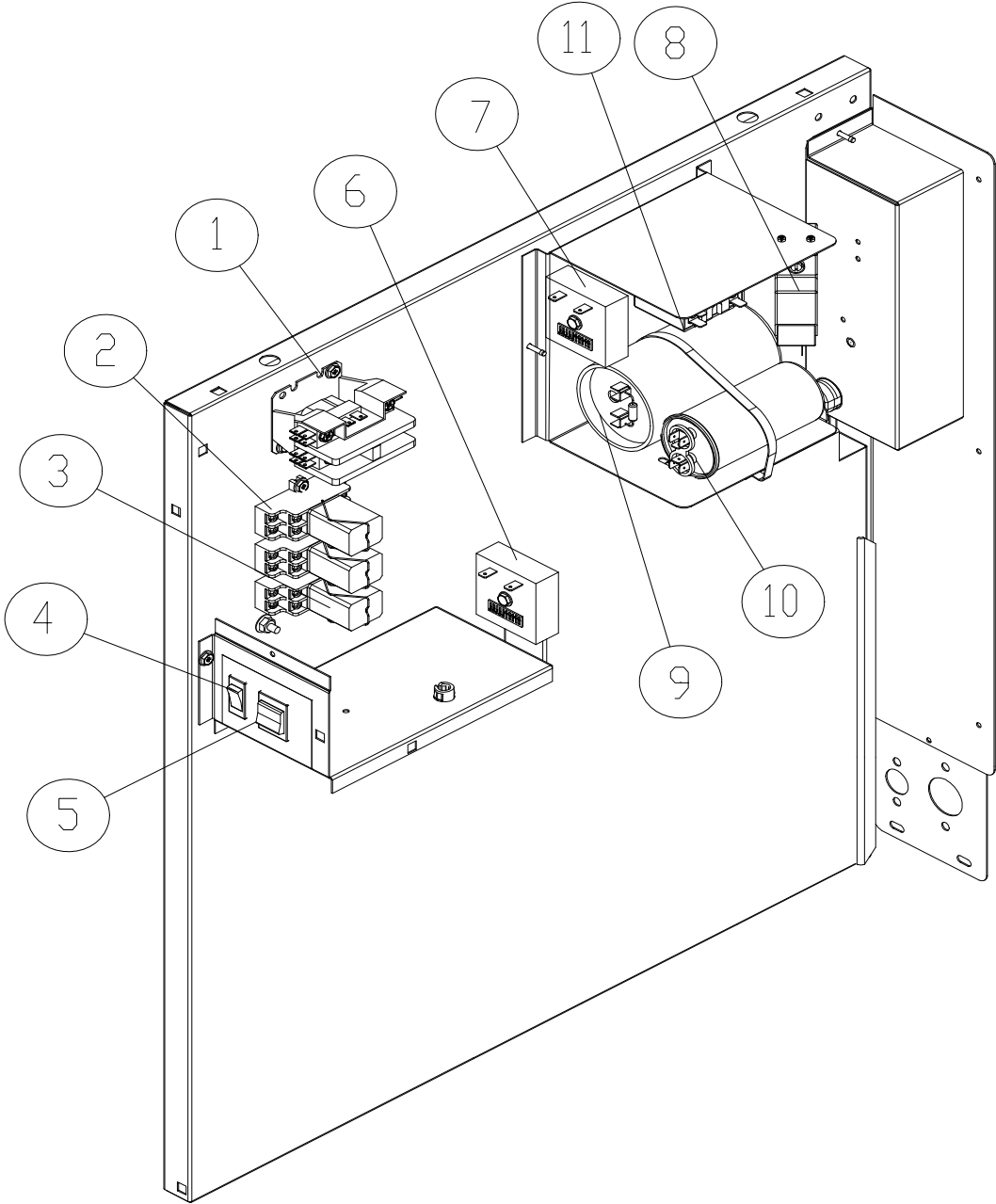

Item No.	ICE1406	ICE1405	ICE1407	Description
1	9101002-06	9101002-06	9101079-02	Contactator
2	9101083-01	9101083-01	9101083-01	Relay Base
3	9101084-02	9101084-02	9101084-02	Relay
4	9101139-03	9101139-03	9101139-03	Purge Switch
5	9101195-01	9101195-01	9101195-01	ICE-OFF-WASH Switch
6	9101148-01	9101148-01	9101148-01	Timer
7	9101148-01	9101148-01	9101148-01	Timer (6 Minute-Remote only)
8	9041104-101A	9041104-101A	9041104-101A	Low Pressure Control (Timer Initiate)
9	See Below	See Below	N/A	Start Capacitor
10	See Below	See Below	N/A	Run Capacitor
11	See Below	See Below	N/A	Compressor Relay

Note: Reference the Compressor Part Number and Manufacture Part Number to insure the correct starting components are supplied for a specific compressor.

Reference the compressor model number to insure the correct starting components are ordered.

If in doubt, request the compressor manufacture part number from the service agent.

Reference the Compressor Model number to insure the correct Starting Componets are ordered.

ICE1406	ICE1405	ICE1407	Description
9181111-11	9181094-12	9181111-12	Compressor Kit NLA=No Longer Available
9181003-19	9181003-34	N/A	Start Capacitor
9181009-12	9181009-20	N/A	Run Capacitor
9181010-10	9181010-04	N/A	Relay

Reference the Compressor Model number to insure the correct Starting Componets are ordered.

9181111-11			CS186KE-PFV-235
	9184094-12		CS20K6E-PFZ-235/275
9181142-11			CS18K6E-PFV-255
	9181143-12		CS20K6E-PFZ-255

The following Compressors are No Long Available and have been replaced

ICE1406	ICE1405	Replacement Compressor
9181111-11		9181142-11 CS18K6E-PFV-255
	9181094-12	9181143-12 CS20K6E-PFZ-255

Reference the Compressor Model number to insure the correct Starting Componets are ordered.

ICE1406	ICE1405	ICE1407	Description
9181142-11	9181143-12	9181111-12	Compressor Kit
9181003-21	9181003-34	N/A	Start Capacitor
9181009-20	9181009-20	N/A	Run Capacitor
9181010-10	9181010-04	N/A	Relay

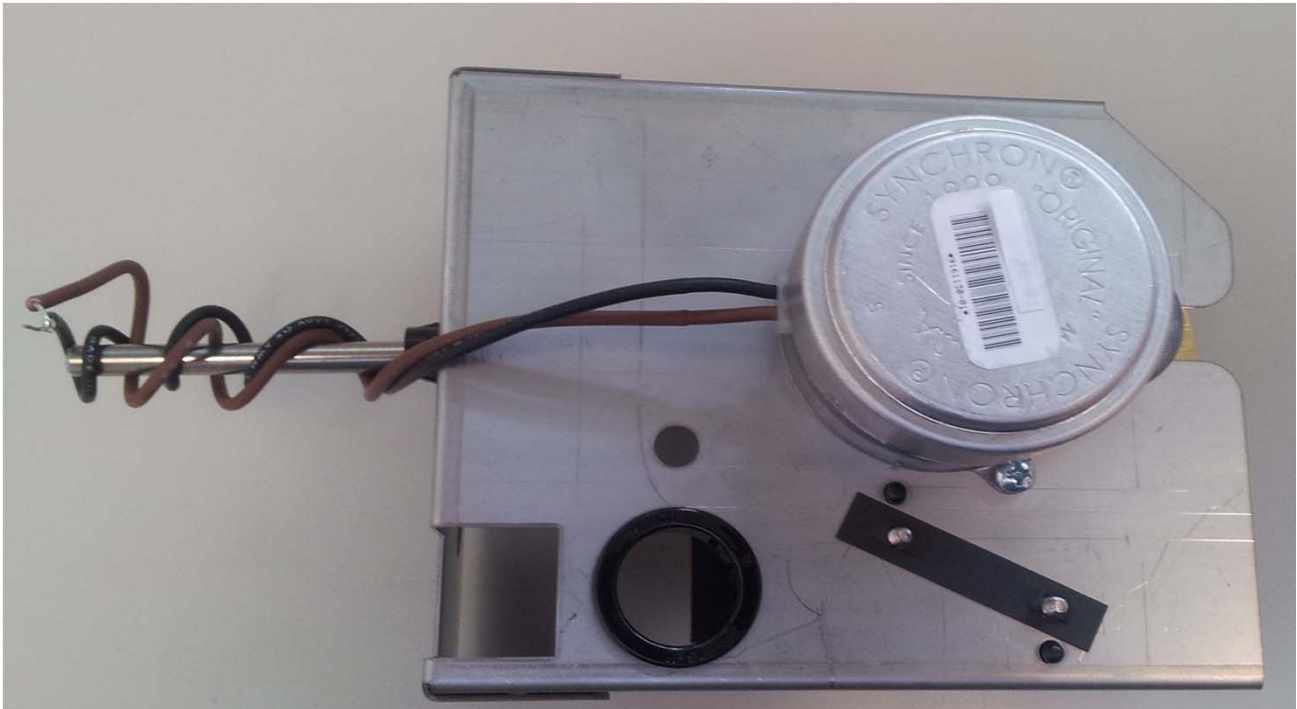

1051210-XX Reference Page 13 for Specific Model Number and Part Number

- The **1051210-XX** assembly will fit all ICE Models from October 1999 and EC Models.
- Units installed with a double cam switch, either Field installed or Factory installed will require the complete assembly and a potential wiring change as per the New Wiring Diagram included with the assembly.
- Individual component parts are not available for the **1051210-XX** assembly.
- Individual component parts are No Longer Available for previous version of the Harvest Assist Assembly
- Parts for the **2061962-XX** Harvest Assist Assembly are not compatible with **1051210-XX** Harvest Assist Assembly.
- Proper assembly and alignment of the parts is critical to proper operation, this includes cam and probe alignment.
- If a **1051210-XX** assembly fails, it must be returned to Ice-O-Matic.

Item No.	Model Number			Description
	ICE1406	ICE1405	ICE1407	
	1051210-02	1051210-02	1051210-02	Complete Assembly-Right Side
	2061962-02S	2061962-02S	2061962-02S	No Longer Available
	1051210-02	1051210-02	1051210-02	Complete Assembly-Right Side Remote Only
	2061962-10S	2061962-10S	2061962-10S	No Longer Available-Secondary-Right Side Remote Only
	1051210-03	1051210-03	1051210-03	Complete Assembly-Secondary-Left Side
	2061962-03S	2061962-03S	2061962-03S	No Longer Available-Secondary-Left Side

LEFT SIDE HARVEST ASSIST (SECONDARY)

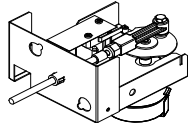
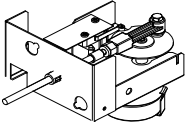

RIGHT SIDE HARVEST ASSIST (PRIMARY)

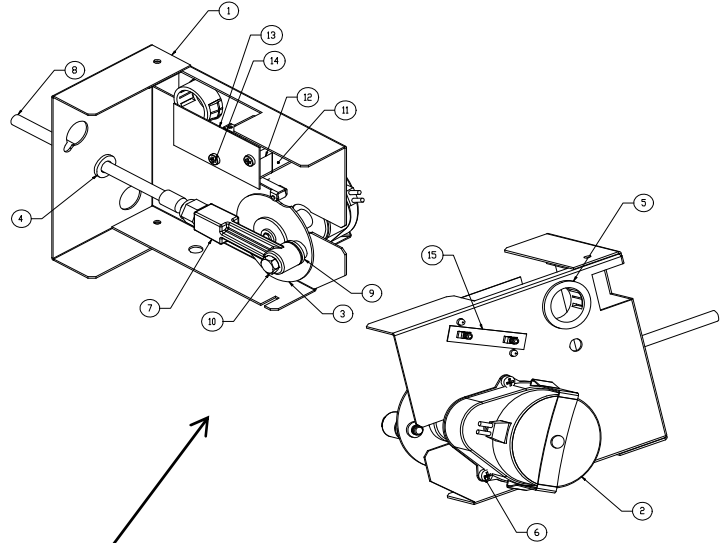

2061962-02S	No Longer Available
2061962-03S	No Longer Available
2061962-10S	No Longer Available

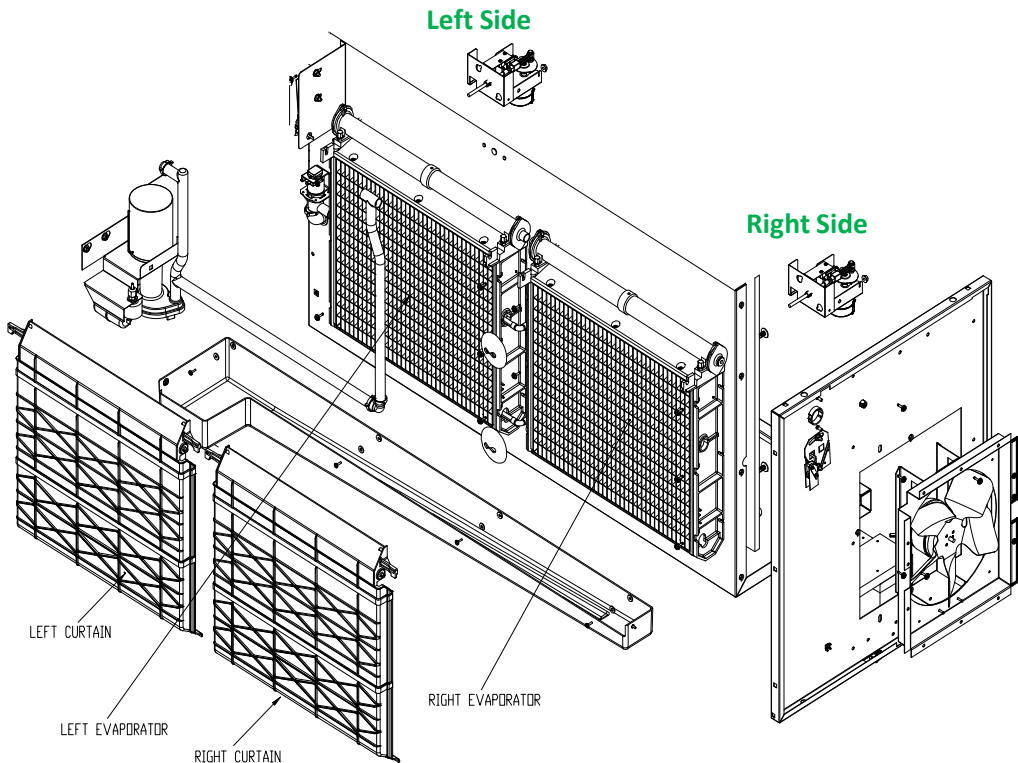

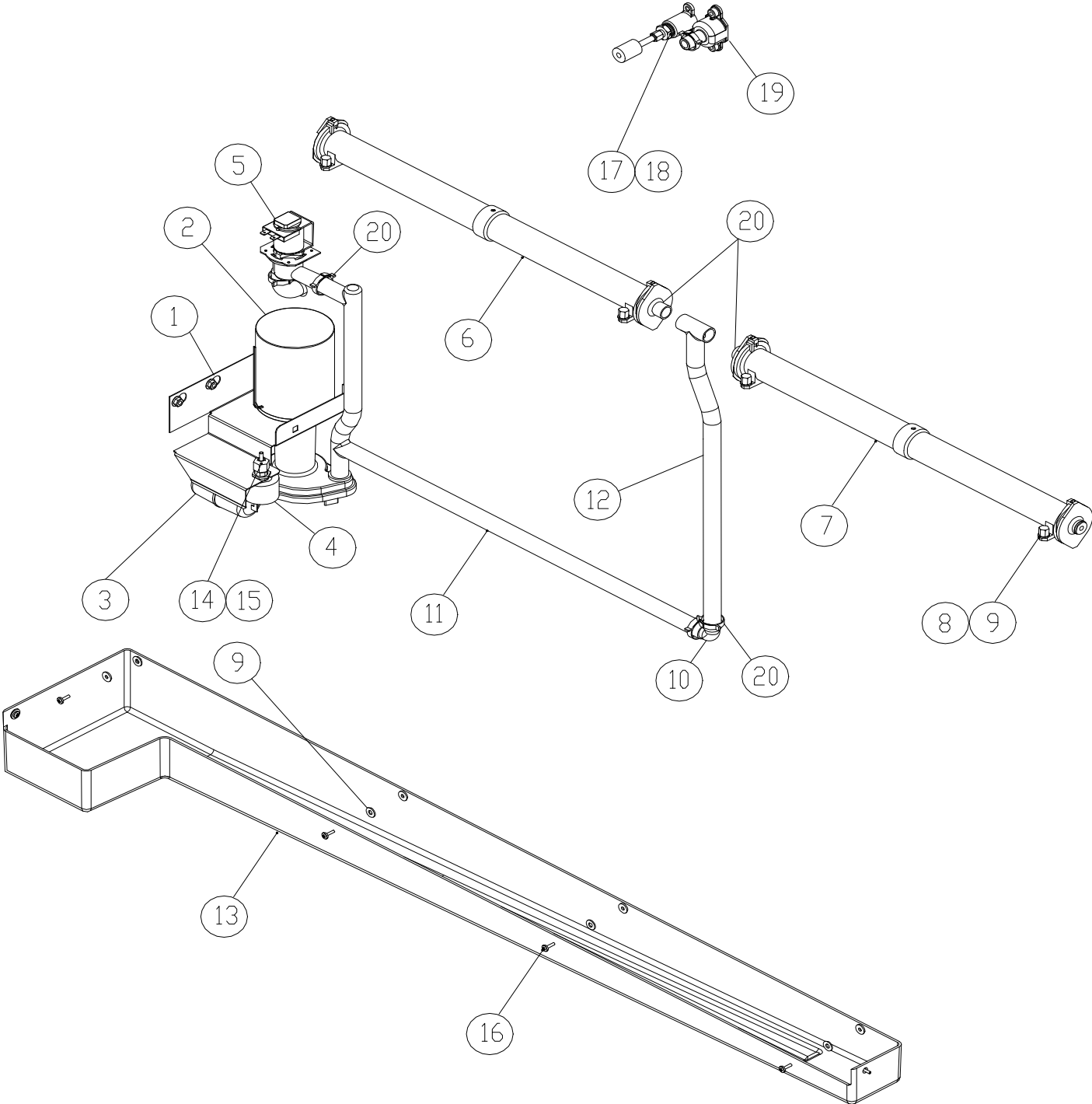

Item No.	Model Number			Description
	ICE1406	ICE1405	ICE1407	
1	3013310-01	3013310-01	3013310-01	Water Pump Bracket
2	9161079-06	9161079-06	9161079-06	Water Pump
3	9131111-102	9131111-102	9131111-102	Float (Includes Fittings)
4	9131026-02	9131026-02	9131026-02	Float Deflector
5	9041105-03	9041105-03	9041105-03	Purge Valve (9041086-03 is NLA)
6	2041338-02	2041338-02	2041338-02	Water Distribution Tube Left
7	2041338-01	2041338-01	2041338-01	Water Distribution Tube Right
8	9031122-01	9031122-01	9031122-01	Thumb Screw
9	9031004-19	9031004-19	9031004-19	Washer
10	9091052-01	9091052-01	9091052-01	Elbow
11	9051546-01	9051546-01	9051546-01	Water Pump Tube (Water Distribution Tube)
12	9051543-01	9051543-01	9051543-01	Water Pump Tube (Water Pump/Purge Valve)
13	9051544-01	9051544-01	9051544-01	Water Trough
14	3032898-26	3032898-26	3032898-26	Water Inlet Tubing (34.00 inches long)
15	9091081-01	9091081-01	9091081-01	Sleeve
	9091080-01	9091080-01	9091080-01	Barrel Fitting
16	9031046-24	9031046-24	9031046-24	Water Trough Screw
17	9091074-01	9091074-01	9091074-01	Drap Adapter
18	9091083-01	9091083-01	9091083-01	Water Inlet Fitting
19	9091140-01	9091140-01	9091140-01	Drain Fitting
20	9021010-04	9021010-04	9021010-04	Clamp

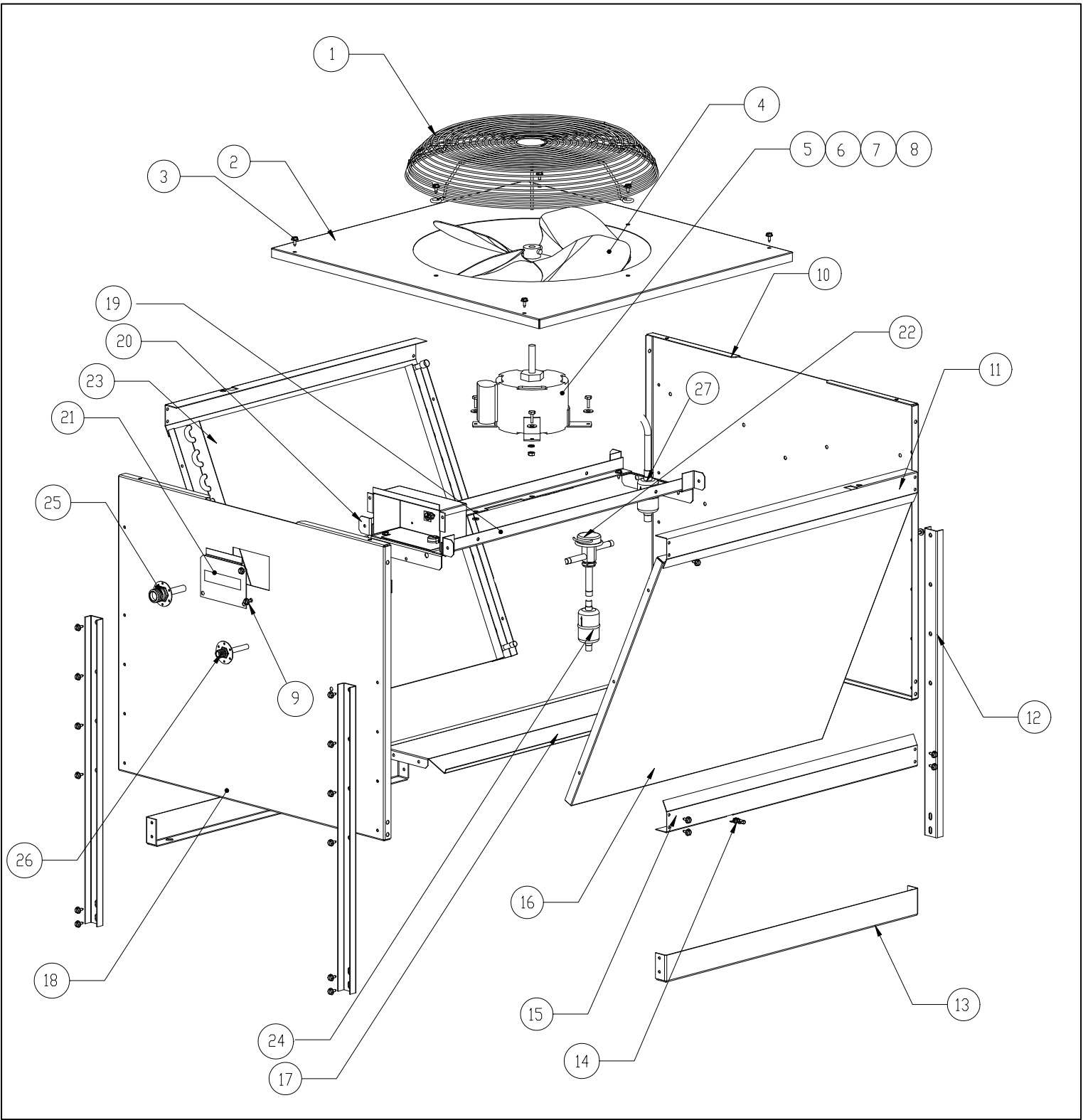

ICE0500R	ICE0600R	ICE0800R ICE1000R	ICE1400R3 ICE1506R3	ICE1800R3 ICE2100R3
----------	----------	----------------------	------------------------	------------------------

Item	VRC1001	VRC1061	VRC2061	VRC2661	VRC5061	Description
1	9131452-01	9131452-01	9131452-01	9131452-01	9131460-01	Fan Guard
2	3013222-01	3013222-01	3013222-01	3013222-01	3013303-01	Top Panel
3	9031019-04	9031019-04	9031019-04	9031019-04	9031019-04	¼-20 x 1/2 Screw
4	9131451-01	9131451-01	9131451-01	9131451-01	9131461-01	Fan Blade
5	9161117-02	9161117-01	9161117-01	9161117-01	9161118-01	Fan Motor
6	9031001-02	9031001-02	9031001-02	9031001-02	9031001-02	¼-20 x ¾ Cap Screw
7	9031003-01	9031003-01	9031003-01	9031003-01	9031003-01	Flat Washer
8	9031118-02	9031118-02	9031118-02	9031118-02	9031118-02	Flanged Lock Nut
9	9031019-04	9031019-04	9031019-04	9031019-04	9031019-04	¼-20 x 1/2 Screw
10	3013224-01	3013224-01	3013224-01	3013224-01	3013224-01	Rear Panel
11	3013226-01	3013226-01	3013226-01	3013226-01	3013305-01	Brace
12	3013227-01	3013227-01	3013227-01	3013227-01	3013227-01	Leg
13	3013228-01	3013228-01	3013228-01	3013228-01	3013306-01	Leg Brace
14	N/A	N/A	N/A	N/A	N/A	T-Nut-Shipping Only
15	3013226-01	3013226-01	3013226-01	3013226-01	3013305-01	Brace
16	3013232-01	3013232-01	N/A	N/A	N/A	Cover Panel
17	3013225-01	3013225-01	3013225-01	3013225-01	3013304-01	Center Panel
18	3013223-01	3013223-01	3013223-01	3013223-01	3013223-01	Front Panel
19	3013234-01	3013234-01	3013234-01	3013234-01	3013307-01	Motor Brace
20	3013233-01	3013233-01	3013233-01	3013233-01	3013233-01	Motor Brace Support
21	3013229-01	3013229-01	3013229-01	3013229-01	3013229-01	Junction Box Cover
22	9151142-02	9151142-02	9151142-02	9151142-02	9151142-02	Mixing Valve
23	9141135-01	9141135-01	9141135-01	9141136-01	9141137-01	Condenser
24	9151143-01	9151143-01	9151143-01	9151143-01	9151143-01	Filter
25	9091001-12	9091001-12	9091001-12	9091001-12	9091001-12	1/2 Coupling
26	9091001-11	9091001-11	9091001-11	9091001-11	9091001-11	3/8 Coupling
27	9151143-02	9151143-02	9151143-02	9151143-02	9151143-02	Filter